

# Queensland Electricity Connection Manual

Service and Installation Rules

Version 4 Draft – June 2023

For consultation purposes only



Part of Energy Queensland

# Queensland Electricity Connection Manual



If this standard is a printed version, to ensure compliance, reference must be made to the Energex or Ergon Energy Network internet site to obtain the latest version.

<b>Approver</b>	<insert Name and Position Title of Asset Management General or Group Manager who reports to the Executive General Manager>	
If <i>RPEQ</i> Sign-off required insert details below.		
Certified Person Name and Position Title	Registration Number	
<insert Name and Position Title>	<insert number>	
<insert Name and Position Title>	<insert number>	

**Abstract:** This *manual* provides information for *Proponents* of *electrical installations* about their obligations in respect to connecting to and interfacing with Energex and Ergon Energy Network's *distribution system*. The document has been developed to ensure the safe and stable operation of *electrical installations* connected to the *distribution system* without causing material degradation in the quality of supply to *distribution system* users.

**Keywords:** connection, *QECM*, load, *embedded generating system*, *DNISP service point*, *service line*, *consumer mains*, *meter board*, metering, *network device*, overhead, underground, *dynamic*.

Copyright © 2023 Energex Limited and Ergon Energy Corporation Limited. This publication is copyright. Except as permitted under the Copyright Act 1968 no part of this publication may be reproduced by any process without the specific written permission of the copyright owner.

All rights reserved.

## CONTENTS

1	Introduction .....	12
1.1	Purpose .....	12
1.2	Scope .....	12
1.2.1	General.....	12
1.2.2	Scope exclusions.....	12
1.3	Disclaimer .....	12
1.4	Safety .....	13
1.4.1	General.....	13
1.4.2	Look up and live.....	14
1.4.3	Before You Dig Australia.....	15
1.5	Obligation of connection participants.....	15
1.5.1	Stakeholder interaction diagrams.....	15
1.5.2	Obligations of connection participants.....	16
1.6	Interpretation of requirements .....	18
1.6.1	General.....	18
1.6.2	Requesting an interpretation enquiry .....	18
1.6.3	Information required for interpretation enquiries.....	19
1.6.4	Interpretation enquiry response timeframes .....	19
1.7	Document management.....	19
1.7.1	Alterations.....	19
1.7.2	Addendums .....	19
1.7.3	Requesting amendments .....	20
1.8	Drawings, figures and tables .....	20
1.8.1	Drawings.....	20
1.8.2	Figures .....	22
1.8.3	Tables.....	23
2	Definitions and abbreviations .....	25
2.1	Definitions .....	25
2.2	Abbreviations .....	32
2.3	Terminology .....	33
2.3.1	Application of requirements .....	33
3	Relevant rules, regulations, standards and codes .....	33
3.1	Standards and codes .....	33

# Queensland Electricity Connection Manual



Part of Energy Queensland

3.1.1	<i>DNSP</i> documents .....	33
3.1.2	Australian standards .....	34
3.1.3	International standards .....	36
3.1.4	Referenced Documents .....	37
3.2	Legislation and regulation .....	37
4	Connection activities .....	39
4.1	Connection applications .....	39
4.1.1	General.....	39
4.1.2	Application process.....	39
4.1.3	Connection offers.....	40
4.1.4	Fees and charges .....	40
4.1.5	<i>Network tariffs</i> .....	41
4.2	New connections.....	42
4.3	Alterations of existing connections .....	43
4.3.1	Application and <i>EWR</i> requirements .....	43
4.3.2	Alteration classifications.....	43
4.3.3	Undertaking repairs .....	44
4.4	Technical studies .....	44
4.4.1	General.....	44
4.4.2	Load connections.....	44
4.4.3	<i>EG system</i> connections .....	45
4.5	<i>Distribution system</i> works .....	45
4.5.1	General.....	45
4.5.2	<i>OH distribution system</i> works.....	45
4.5.3	<i>UG distribution system</i> works.....	46
4.6	Connection, examination and testing .....	46
4.6.1	General.....	46
4.6.2	Initial connection to the <i>distribution system</i> .....	46
4.6.3	Reconnection to the <i>distribution system</i> .....	47
4.6.4	Breaking <i>metering installation</i> or <i>network device</i> seals .....	47
4.7	Authorised activities .....	47
4.7.1	General.....	47
4.7.2	<i>Authorised person</i> .....	47
4.7.3	Authorised activities .....	48
4.7.4	Non-authorised activities.....	48

# Queensland Electricity Connection Manual



Part of Energy Queensland

4.8	Activities requiring approval .....	48
4.8.1	General.....	48
4.8.2	Protected items.....	50
4.8.3	Unmetered supply.....	51
4.9	Activities requiring <i>professional engineering services</i> .....	51
4.10	Failure to comply.....	53
4.10.1	General.....	53
4.10.2	Notification of failure to comply .....	53
4.10.3	Rectification of non-compliances .....	53
5	General connection and supply requirements .....	54
5.1	Provision of supply .....	54
5.1.1	General.....	54
5.1.2	Availability of supply .....	54
5.2	<i>DNISP service point</i> .....	54
5.2.1	General.....	54
5.2.2	Charges for <i>DNISP service point</i> .....	55
5.2.3	Provision of access to the <i>DNISP service point</i> .....	55
5.2.4	Provisions of <i>consumer mains</i> and means to terminate .....	55
5.2.5	Provision of an additional <i>DNISP service point</i> .....	56
5.2.6	Converting from multiple <i>LV DNISP service points</i> to a <i>HV DNISP service point</i> .....	57
5.3	Determining number of phases .....	58
5.4	<i>Connection Point</i> .....	59
5.4.1	General.....	59
5.4.2	Additional <i>connection points</i> at a <i>premises</i> .....	59
5.5	Connection types .....	60
5.5.1	General.....	60
5.5.2	<i>Embedded networks</i> .....	61
5.5.3	Subdivisions .....	62
5.6	Have one <i>connection point</i> per lot. Note only one <i>connection point</i> shall be provided for a <i>common property</i> lot e.g. a community meter. Multiple <i>electrical installations</i> .....	63
5.6.1	General.....	63
5.6.2	Multiple distribution transformers .....	63
5.6.3	Identification in <i>premises</i> with multiple <i>electrical installations</i> .....	65
5.7	Supply beyond a property boundary.....	66
5.8	<i>Active device management</i> .....	67

# Queensland Electricity Connection Manual



Part of Energy Queensland

5.9	Non-standard connection and supply arrangements .....	67
5.9.1	<i>Isolated networks</i> .....	67
6	Overhead connection and supply requirements .....	68
6.1	General .....	68
6.2	<i>DNSP service point</i> .....	68
6.3	<i>OH service line</i> .....	68
6.3.1	Provision of access to the <i>service line</i> .....	69
6.3.2	Provisions of means to terminate <i>service line</i> .....	69
6.4	Unsuitable routes or <i>point of attachment</i> locations for <i>OH service lines</i> .....	70
6.5	<i>OH service line cable</i> .....	70
6.6	Provision of <i>point of attachment</i> for <i>OH service line</i> .....	71
6.6.1	Provision of <i>point of attachment</i> for <i>OH service line</i> .....	71
6.6.2	Provision of space and facilities for future connection assets .....	72
6.7	<i>OH point of attachment</i> and <i>DNSP service point</i> .....	72
6.7.1	General .....	72
6.7.2	Provision of means to terminate service <i>LV OH service line</i> at <i>point of attachment</i> ..	72
6.7.3	<i>OH service line</i> attachment and <i>connection point</i> requirements .....	72
6.7.4	Termination of <i>LV OH service line</i> .....	75
6.7.5	Raiser bracket .....	76
6.7.6	Property pole .....	77
6.8	Non-standard <i>OH</i> connection and supply arrangements .....	79
6.8.1	<i>Consumer mains</i> on <i>DNSP</i> pole .....	79
6.8.2	Single Wire Earth Return ( <i>SWER</i> ) .....	79
6.9	Builders temporary supply .....	80
7	Underground connection and supply requirements .....	81
7.1	General .....	81
7.2	<i>UG DNSP service point</i> .....	81
7.3	Unsuitable locations <i>connection assets</i> for <i>UG DNSP service point</i> .....	82
7.4	Provision of space and facilities for <i>UG connection assets</i> .....	82
7.5	Provision of <i>consumer mains</i> for <i>UG</i> connection .....	83
7.6	<i>UG point of attachment</i> and <i>connection point</i> requirements .....	83
7.6.1	General .....	83
7.6.2	<i>UG</i> Pillar .....	84
7.6.3	<i>Consumer mains</i> and conduit .....	85
7.7	Non-standard <i>UG</i> connection arrangements .....	86

# Queensland Electricity Connection Manual



Part of Energy Queensland

7.7.1	UG DNSP service point from OH service area.....	86
7.7.2	CBD.....	87
7.7.3	Pit.....	87
7.8	Connection to interim structure during construction.....	87
8	Electrical installation requirements .....	88
8.1	General.....	88
8.2	Labelling, identification, and signage.....	88
8.2.1	General.....	88
8.2.2	Consumer mains conductor labelling and identification.....	88
8.2.3	Metering active link and metering neutral link labelling.....	88
8.2.4	Small IES labelling and signage.....	89
8.2.5	Premises with multiple services .....	89
8.3	Voltage .....	89
8.4	Phase balancing .....	89
8.5	Determining system limits .....	90
8.5.1	General.....	90
8.5.2	EVSE dynamic and fixed import limits.....	90
8.6	Distribution system fault levels .....	91
8.7	Protection.....	92
8.7.1	General.....	92
8.7.2	Protective fault current devices.....	92
8.7.3	Main switch.....	92
8.8	Earthing .....	93
8.8.1	General.....	93
8.8.2	Earthing for premises with multiple DNSP service points .....	93
8.8.3	Earthing for distribution transformers on premises .....	93
8.9	Power quality .....	93
8.9.1	General.....	93
8.9.2	Power factor .....	94
8.9.3	Harmonic emissions .....	94
8.9.4	Harmonic interference or waveform distortion .....	94
8.9.5	Rectifiers.....	94
8.10	Active device management .....	95
8.10.1	General.....	95
8.10.2	Emergency backstop mechanism .....	95

# Queensland Electricity Connection Manual



Part of Energy Queensland

8.10.3	PeakSmart.....	96
8.10.4	<i>Dynamic</i> .....	97
8.10.5	Basic active management via <i>network device</i> .....	97
8.11	Communication systems .....	97
8.11.1	General.....	97
8.11.2	Connection of communications system.....	98
8.11.3	Information exchange .....	98
8.12	Data and information.....	98
8.12.1	Static data and information .....	98
8.12.2	<i>Dynamic</i> data and information .....	98
8.13	Cyber security .....	98
8.14	Load connections.....	98
8.14.1	Determining maximum demand .....	98
8.14.2	Equipment selection .....	98
8.14.3	Equipment with fluctuating load .....	100
8.14.4	Electric vehicle supply equipment.....	100
8.14.5	AC motors.....	100
8.15	Generating system connections .....	101
8.15.1	Equipment selection .....	101
8.15.2	Design and installation.....	102
8.16	Dual load and generating system equipment .....	103
8.16.1	General.....	103
8.16.2	Vehicle to Grid (V2G) EVSE .....	103
8.16.3	Battery <i>energy storage system</i> (BESS).....	103
9	<i>Network device</i> and metering general requirements.....	104
9.1	General.....	104
9.2	<i>Network devices</i> .....	104
9.2.1	General.....	104
9.2.2	Provision of space for <i>network devices</i> .....	104
9.3	Metering classification.....	105
9.4	Authorised metering activities .....	105
9.4.1	General.....	105
9.4.2	<i>DNISP</i> activities .....	105
9.4.3	<i>Metering providers</i> activities.....	105
9.5	Provision of <i>meter board</i> and space to locate .....	105

# Queensland Electricity Connection Manual



Part of Energy Queensland

9.6	Provision of access to <i>meter board</i> .....	106
9.7	Provision of utility access locks .....	106
9.8	<i>Meter board</i> location .....	107
9.8.1	General.....	107
9.8.2	<i>Meter board</i> location requirements for <i>domestic premises</i> .....	110
9.8.3	<i>Meter board</i> location requirements for <i>non-domestic premises</i> .....	110
9.8.4	<i>Meter board</i> location requirements for community title premises.....	110
9.8.5	Multiple metering points .....	111
9.9	<i>Meter board</i> enclosure requirements.....	112
9.9.1	Asbestos safety warning .....	112
9.9.2	<i>Meter board</i> enclosure on property pole .....	112
9.10	<i>Meter board</i> enclosure installation.....	112
9.10.1	General.....	112
9.10.2	Mechanical protection of meters board enclosures .....	112
9.10.3	Mounting <i>meter board</i> enclosures.....	113
9.10.4	CT metering housing .....	113
9.10.5	<i>Meter board</i> enclosure earthing .....	113
9.10.6	Platform requirements.....	114
9.11	Approval of metering and <i>electrical installation</i> designs .....	114
9.11.1	General.....	114
9.11.2	LV CT metering drawings .....	114
9.11.3	HV metering and <i>electrical installation</i> .....	115
10	LV connected <i>network device</i> and metering requirements.....	116
10.1	Metering isolation and connection devices .....	116
10.1.1	General requirements .....	116
10.1.2	Metering Isolation Link (MIL) requirements .....	116
10.1.3	<i>Circuit Breaker (CB) requirements</i> .....	117
10.1.4	Isolator requirements .....	117
10.1.5	Metering active and Meter Neutral links .....	117
10.1.5.1	Metering Active Links .....	118
10.1.5.2	Metering neutral links.....	118
10.2	Isolation of direct connected metering.....	118
10.3	Isolation of CT metering .....	120
10.3.1	General.....	120
10.3.2	For multiple <i>domestic</i> or <i>non-domestic premises</i> .....	120

# Queensland Electricity Connection Manual



Part of Energy Queensland

10.3.3	Non-standard legacy CT <i>metering installations</i> .....	121
10.4	Non-standard metering arrangements.....	121
10.4.1	Card Operated Metering .....	121
10.5	Metering neutral requirements .....	121
10.5.1	Connection of metering neutral conductors.....	121
10.5.2	Accessibility of neutral conductors .....	122
10.6	<i>LV network device</i> and metering requirements.....	122
10.6.1	Spacing requirements .....	122
10.6.2	Mounting metering and <i>network device</i> equipment .....	122
10.6.3	<i>Proponent</i> obligations to provide access for <i>network device</i> .....	123
10.6.4	<i>Proponent</i> obligations to provide wiring for metering and <i>network devices</i> .....	124
10.6.5	<i>Network device</i> requirements.....	124
10.7	<i>EG</i> system metering.....	126
10.7.1	<i>EG</i> metering schemes available .....	126
10.7.2	Solar bonus schemes and Power Purchase Agreements.....	126
10.7.3	Approval of equipment.....	126
11	<i>HV</i> connected metering requirements .....	127
11.1	General requirements .....	127
11.2	<i>DNSP</i> metering requirements review .....	127
11.3	<i>HV</i> metering equipment .....	127
11.3.1	General.....	127
11.3.2	<i>HV metering installation</i> general requirements.....	128
11.4	<i>HV</i> installation of metering equipment.....	129
11.4.1	<i>HV</i> metering location .....	129
11.4.2	Metering enclosure .....	129
11.4.3	Secondary wiring .....	129
11.5	Testing requirements .....	130
11.6	Operation of <i>HV</i> equipment.....	130
11.7	Maintenance and repairs of <i>HV</i> equipment .....	130
12	Testing and commissioning .....	131
12.1	<i>LV</i> connections .....	131
12.2	<i>HV</i> connections.....	131
13	Operations and maintenance.....	133
13.1	<i>Proponent</i> obligations .....	133
13.2	<i>Dynamic</i> operation .....	133

# Queensland Electricity Connection Manual



Part of Energy Queensland

13.3	<i>DNISP</i> obligations.....	133
13.4	<i>Distribution system</i> maintenance .....	134
Appendix A:	<i>QECM</i> drawings (normative).....	135
A.1:	Section 5 – General connection and supply requirement drawings .....	136
A.2:	Section 6 – Overhead connection and supply requirement drawings .....	144
A.3:	Section 7 – Underground connection and supply requirement drawings .....	163
A.4:	Section 8 – Electrical installation requirements .....	164
A.5:	Section 9 – Network device and metering general requirements.....	166
A.6:	Section 10 – LV connected network device and metering requirements .....	171
Appendix B:	Activities requiring approval (normative) .....	184
Appendix C:	Model standing offer (informative).....	186
Appendix D:	Static data and information (informative).....	187
Appendix E:	<i>Dynamic</i> data and information (informative).....	188
Appendix F:	Compliance checklists (informative) .....	189
Appendix G:	<i>Isolated Networks</i> (normative) .....	191
G.2	Maximum permitted rating of AC motors in isolated networks .....	192
Appendix H:	Specification for metallic enclosures for direct connected <i>metering installations</i> (normative).....	193
Appendix I:	Controlled tariff requirements (normative) .....	196
Appendix J:	Alterations of existing connections (normative).....	198
Appendix K:	Stakeholder interactive diagrams for connection participants (normative).....	200
K.1:	Initial connection of direct connected metering.....	201
K.2:	Initial connection of current transformer (CT) metering .....	202
K.3:	<i>Electrical installation</i> work involving metering changes .....	203
K.4:	Service and metering change for phase upgrade.....	204
K.5:	Service alteration without metering changes .....	205
K.6:	<i>Small IES EG</i> connection to an <i>electrical installation</i> .....	206
K.7:	Initial connection for a <i>HV</i> connection .....	207
Appendix L:	<i>DNISP</i> service area map (informative) .....	208
Appendix M:	Card Operated Meter Service Areas.....	209
Appendix N:	<i>DNISP</i> contact details (informative) .....	210

## 1 Introduction

### 1.1 Purpose

The purpose of this *manual* is to provide information for *Proponents of electrical installations* about their obligations in respect to connecting to and interfacing with the DNSP's *distribution system*. It has been developed to ensure the safe and stable operation of *electrical installations* connected to the *distribution system* without causing material degradation in the quality of supply to *distribution system* users.

The document is for use by *Electrical Contractors, Engineers, consultants, builders, developers, architects, Metering Providers*, and others directly concerned with *electrical installations* that are connected, or are to be connected, to the *distribution system*.

### 1.2 Scope

#### 1.2.1 General

This *manual* applies to establishing, altering, maintaining and the ongoing operation of load and *embedded generating (EG)* system connections.

The scope of this document encompasses:

- (a) those *electrical installations* (in part or in whole) that are capable of:
  - (i) taking supply from the *distribution system*; or
  - (ii) operating in Parallel with the *distribution system*.
- (b) the *metering installation*, inclusive of *network devices* and metering;
- (c) *small Customers*, large market *Customers*, unmetered supplies, and connections to *isolated networks*;
- (d) setting out the applicable technical requirements.

#### 1.2.2 Scope exclusions

This *manual* does not:

- (a) Apply to *off-grid generating units* and electrical circuits which are not capable of interconnection with the *distribution system* at any time. Note this *manual* does specify requirements for any interface between *off-grid* generating systems, electrical circuits and the *distribution system*, such as *break-before-make* isolating device requirements, to ensure safe and secure separation from the *distribution system*.
- (b) Apply to *metering installations* for child metering that form part of an *embedded network*.
- (c) Replace the DNSP requirements for construction of *connection assets* intended to form part of the *distribution system*.
- (d) Replace a *Proponent's* obligation to meet Queensland Electricity legislation for the design, installation, operation, and maintenance of an *electrical installation*.

### 1.3 Disclaimer

The Queensland Electricity Connection Manual (QECM) has been compiled in conjunction with both DNSPs. The QECM is the service and installation rules as referred to in the terms of the deemed standard connection contract.

Whilst this *manual* contains material relevant to the electricity industry legislation, codes of practice and standards, it is not intended to provide legal advice on how *Electrical Contractors* can meet their own statutory obligations or comply with legislation, codes of practice or industry standards.

# Queensland Electricity Connection Manual



This *manual* does not provide advice for the purposes of Section 68 of the Electrical Safety Regulation 2013 (Qld). The Electrical Safety Act 2002 (Qld), Electrical Safety Regulation 2013 (Qld) and associated codes of practice establish requirements for electrical safety and place obligations on employers, self-employed persons, and others.<sup>1</sup>

This *manual* shall be read in conjunction with the *energy laws*, other relevant legislation, codes of practice, Australia Standards and in particular AS/NZS 3000, the National Electricity Rules (*NER*) and the Metering Installation Requirements (*MIR*).

Whilst care has been taken in the preparation of this *manual*, the *DNSPs* do not guarantee that the information contained in the *manual* is accurate, complete, or up to date at time of publication. To the extent permitted by the relevant legislation the *DNSP* will not be responsible for any loss, damage, cost, or expense incurred as a result of any error, omission or misrepresentation in relation to the information contained in this *manual*.

This *manual* supersedes previous versions of the *DNSP's* electricity connection and metering *manuals*.

## 1.4 Safety

### 1.4.1 General

In all activities undertaken, the safety of our employees, contractors, *Customers* and the community is paramount. Safety is our number one value and there is a commitment to ensuring safety is a priority to achieve a no injuries workplace.

In accordance with legislative requirements, we have developed policies, standards, and work practices that our employees are required to follow to ensure the safety of themselves, other workers, *Customers* and the community.

Our employees will not undertake any work in a situation where there are uncontrolled risks, inconsistent with our safe systems of work.

For anyone contemplating working or operating plant near any *DNSP* overhead or underground electric lines, requirements are available at the links shown in Table 1.

---

<sup>1</sup> These documents may be obtained from the Queensland Government website [www.worksafe.qld.gov.au](http://www.worksafe.qld.gov.au).

# Queensland Electricity Connection Manual

Table 1 *DNSP* requirements for working near overhead and underground electric lines

<i>DNSP</i>	Requirements for working near overhead and underground electric lines
Energex	<a href="https://www.energex.com.au/home/safety/working-near-powerlines">https://www.energex.com.au/home/safety/working-near-powerlines</a>
	<a href="https://www.energex.com.au/_data/assets/pdf_file/0004/344470/Working-Near-Overhead-and-Underground-Electric-Lines-WP1323.pdf">https://www.energex.com.au/_data/assets/pdf_file/0004/344470/Working-Near-Overhead-and-Underground-Electric-Lines-WP1323.pdf</a>
Ergon Energy Network	<a href="https://www.ergon.com.au/network/safety/working-near-powerlines">https://www.ergon.com.au/network/safety/working-near-powerlines</a>
	<a href="https://www.ergon.com.au/_data/assets/pdf_file/0010/211231/BS001405R107-Electricity-Entity-Requirements-Working-near-OH-and-UG-Electric-Lines.pdf">https://www.ergon.com.au/_data/assets/pdf_file/0010/211231/BS001405R107-Electricity-Entity-Requirements-Working-near-OH-and-UG-Electric-Lines.pdf</a>

## 1.4.2 Look up and live



**Lookupandlive.com**



Business owners, machinery operators, and other workers working near powerlines should take appropriate actions to work safely near powerlines.

Our [Lookupandlive.com](https://www.lookupandlive.com) app is a powerline mapping application that's assists in adequately planning work near powerlines. This tool may help prevent contact and reduce the risk of injury or death from electrocution and damage to equipment and our electricity network.

It's a simple tool can be found at [www.lookupandlive.com.au](https://www.lookupandlive.com.au) to assist you to safely plan and/or perform work around the electricity network by providing:

- (a) Overhead powerline locations and imagery via an interactive geospatial map.
- (b) Powerline safety guidelines, including powerline exclusion zones.
- (c) Options for planning or performing work e.g., powerline visual indicators.
- (d) Information on de-energisation or relocation of powerlines.
- (e) Safety advice and high load forms.
- (f) Supply abolishment.
- (g) Dial Before You Dig enquiry.

You can also download this map as the Look up and Live app using the QR code below:



## 1.4.3 Before You Dig Australia



Whenever you start digging, there's a risk you'll come across underground electricity lines. Accidental contact with energised cables can put you and your teammates at risk of electric shock. To stay safe, locate underground powerlines before you break ground.

Before You Dig Australia (BYD) is the national referral service for information on the location of underground infrastructure. Australia's major service providers have a single web-enabled information service for information on the location of underground communications, gas, water, and electricity infrastructure. The BYDA online service is available 24 hours a day and enables users to have more control over their enquiry as you detail the dig site on the mapping software yourself.

Use the website [www.byda.com.au](http://www.byda.com.au) to ensure that you 'Before You Dig' before any excavation work.

You can also download the BYDA app using the links below:

- (a) Download from the Apple App Store  
<https://apps.apple.com/au/app/dbyd/id1550241756>
- (b) Download from Google Play  
<https://play.google.com/store/apps/details?id=com.dbyd>

## 1.5 Obligation of connection participants

### 1.5.1 Stakeholder interaction diagrams

Stakeholder interactive diagrams for process interactions between connection participants are provided in Appendix K for the common connection activities shown in Table 2.

**Table 2 Common connection activities for stakeholder interaction diagrams**

Diagram number	Connection activity
K.1	Initial connection of direct connected metering
K.2	Initial connection of current transformer (CT) metering
K.3	<i>Electrical installation</i> work involving metering changes
K.4	Service and metering change for phase upgrade
K.5	Service alteration without metering changes
K.6	<i>Small IES EG</i> connection to an <i>electrical installation</i>
K.7	Initial connection for a <i>HV</i> connection

Note 1: Stakeholder interactive diagrams are representative only. There may be additional interactions between connection participants or other stakeholders. Additionally, interactions may be subject to variation due to changes in the *energy laws*.

## 1.5.2 Obligations of connection participants

### 1.5.2.1 Customer obligations

A *Customer* shall:

- (a) Select an electricity *Retailer*.
- (b) Negotiate or nominate an agent to negotiate provision of the electricity supply with the *DNSP Metering Coordinator*, where applicable.
- (c) Comply with this *manual* and the terms and conditions of the relevant *connection contract*.
- (d) Contact their *Retailer* when advised by an *Electrical Contractor*.
- (e) Ensure trees are cut/trimmed to provide clear access for initial connection of an overhead service.
- (f) Provide a safe working environment for the electrical workers including, but not limited to, *Electrical Contractors* and meter readers.
- (g) Ensure the *meter board* is accessible at all times. Where a *meter board* is behind a locked gate, ensure that the gate is fitted with the utility access lock.
- (h) Ensure the *meter board* is clear of vegetation and that the meter reader can read the meter without stepping on or damaging plants.
- (i) Ensure that the *point of attachment* is clear at all times to allow safe access by *DNSP* employees.
- (j) Ensure any changes to the *premises* including building, fencing, structural or landscaping works does not impact on ongoing compliance with this *manual*.
- (k) Ensure that anything connected to the *distribution system* at the *connection point* is operated in a manner that is compliant with the *QECM* and any other requirements.
- (l) Notify the *Retailer*, *DNSP* and *Metering Provider* when supply is to be permanently disconnected from a *premises*, known as supply abolishment.
- (m) Contact the prior to any work being done that may impact on the *metering installation*.

### 1.5.2.2 DNSP obligations

The *DNSP* shall:

- (a) Negotiate provision of the electricity supply with the *Customer* or the *Customer's* nominated agent, generally an *Electrical Contractor*.
- (b) Transport and deliver electricity on the *distribution system* which is purchased by *Retailers* and sold to *Customers*.
- (c) Examine and test the *consumer mains*, main switchboard, and MEN of a *Customer's* installation before it is initially connected to the *distribution system*.
- (d) Provide metering services in areas exempt from power of choice and where the transitional provisions apply.
- (e) Provide *network devices*.
- (f) Connect the electricity supply to a *Customer's electrical installation* up to the line side of the Metering Isolation Links (subject to rectification of any defects) and subject to the *Customer* selecting a *Retailer*, and the *Retailer* requesting the connection.
- (g) Be responsible for the reliability and quality of the electricity supply at the *connection point*.
- (h) Be responsible for the issue of a *National Metering Identifier (NMI)* for each *metering installation* (other than at a *child connection point* in an *embedded network*).

### 1.5.2.3 Retailer obligations

The *Retailer* shall:

- (a) Purchase electricity and sell it to *Customers*.
- (b) Nominate prices and negotiate contracts where applicable, for the sale of electricity to *Customers*.
- (c) Provide the *DNSP* with details of the *Metering Coordinator* and/or *Metering Provider*, for connections where the *DNSP* is not the *Metering Provider*.
- (d) Request the *DNSP* to connect, disconnect or alter the *Customer's electrical installation* in accordance with the *Customer's* retail contract (Service Order Request if applicable).

## 1.5.2.4 **Metering Coordinator obligations**

The *Metering Coordinator* shall appoint a *Metering Provider* for a retail *Customer*.

## 1.5.2.5 **Metering Provider obligations**

The *Metering Provider* shall:

- (a) Supply, install and maintain the metering equipment on a *Customer's premises* in accordance with this *QECM*, when appointed by the *Metering Coordinator*.
- (b) Ensure all *Customer* energy is metered and notify the *DNSP*, via the appropriate notification form of any unmetered circuits identified.
- (c) Cease any work and notify the *DNSP* immediately on detecting evidence of tampering of metering or associated *network devices*.
- (d) Retain or utilise *DNSP's network devices* where the *Customer* requires controlled tariffs.
- (e) Notify the *DNSP* by the appropriate process prior to conducting any onsite works for *electrical installations* where the *Metering Provider* is not the *DNSP*.
- (f) Comply with *DNSP's* requirements for installation, sealing and testing of metering equipment for *metering installations* where the *DNSP* is the *Metering Provider*.
- (g) Attach a label to the *metering installation* detailing the *NMI*, the *Metering Provider* and *Metering Provider* contact details.
- (h) Ensure that all safety and security requirements are maintained for all types of *metering installations*.
- (i) Inspect and confirm the *metering installation* is compliant with this *QECM* and relevant safety requirements, and issue corrective action notices if defects are identified.

## 1.5.2.6 **Electrical Contractor obligations**

The *Electrical Contractor* shall:

- (a) Ensure all electrical work is in accordance with this *manual*, the *energy laws*, AS/NZS 3000 and other relevant legislation and standards.
- (b) Design and install safe and secure *electrical installations*. Specifically, an *Electrical Contractor* shall ensure that unterminated cables cannot be energised by inserting a fuse or link or by closing a switch or circuit breaker.
- (c) Have and maintain any relevant qualifications, licences or registrations required for work being undertaken for an *electrical installation*.
- (d) Engage a Registered Professional *Engineer* of Queensland (*RPEQ*), in an appropriate discipline, where engineering services are required for design or commissioning of *connection assets*, *electrical installation* or associated structures.
- (e) Design and install *electrical installations* which do not require variation to the requirements in the *QECM*.
- (f) Advise the *Customer* when increases in load require changes to the *electrical installation* including meter changes.

- (g) Advise the *DNSP* when a proposed installation of addition electrical load at a Proponent's premises would increase the maximum demand above the DNSP service fuses or above the approved demand for the premises.
- (h) Not work on or remove metering equipment unless they are the appointed *Metering Provider*.
- (i) Advise the *Customer* that they must contact the *Retailer* to notify that electrical work is completed, immediately after electrical work is completed that involves metering or metering alterations.
- (j) Issue the *Customer* with a certificate of testing and compliance for electrical works completed on an *electrical installation*.
- (k) Submit appropriate forms to the *DNSP* in a timely manner, ensuring the information on the forms is complete and accurate.
- (l) Notify the *Metering Provider* of any broken metering seals.
- (m) Notify the *DNSP* of any broken *network device* seals.
- (n) Rectify any departures from this *manual* that have been identified by the *DNSP* or *Metering Provider*.

## 1.5.2.7 Electrical consultant obligations

The electrical consultant shall:

- (a) Ensure all design, commissioning or other works associated with an *electrical installation* is undertaken in accordance with this *manual*, the *energy laws*, AS/NZS 3000 and other relevant legislation and standards.
- (b) Have and maintain any relevant qualifications, licences or registrations required for work being undertaken for an *electrical installation*.
- (c) Ensure all design, commissioning or other works associated with an *electrical installation* is undertaken without requiring variation to the requirements in the *QECM*.
- (d) Liaise with the *DNSP* to ensure adequate supply is available for large projects.
- (e) Advise the *DNSP* when a proposed installation of addition electrical load at a Proponent's premises would increase the maximum demand above the DNSP service fuses or above the approved demand for the premises.
- (f) Advise the *Customer* when increases in load require changes to the *electrical installation* including meter changes.

## 1.6 Interpretation of requirements

### 1.6.1 General

The *DNSPs* provide technical support for Licenced Electrical Workers requiring interpretation advice for this *manual*, to support safe, secure, and compliant *electrical installations*.

The *DNSP's* technical support personnel are not able to provide interpretation advice for the:

- (a) application of Australian Standards, including AS/NZS 3000 or the AS/NZS 4777 series; or
- (b) the *energy laws*, other legislation, codes, or rules.

Additionally, an interpretation enquiry is not a request for variation. A *Proponent* shall ensure design, installation, commissioning and operation in compliance with this *manual*, see clause 4.10. A request for amendment to this *manual* can be submitted as outlined in clause 1.7.3 of this *manual*.

### 1.6.2 Requesting an interpretation enquiry

To request interpretation advice for this *manual* a Licenced Electrical Workers should submit an enquiry to the DNSP technical support team by phone or email.

For contact details refer to the 'technical information and *QECM* advice' contacts in Appendix N at the back of this *manual*.

To submit a request a Licenced Electrical Workers will require relevant information specified in clause 1.6.3. Enquiry response timeframes are shown in clause 1.6.4.

### 1.6.3 Information required for interpretation enquiries

To request an interpretation enquiry for this *manual* a Licenced Electrical Worker is required to provide the *DNISP* with information relevant to the proposed new connection or connection alteration. As a minimum, the information in Table 3 shall be provided to the *DNISP* by phone or email as part of an interpretation enquiry. See clause 1.6.2 for guidance on requesting an interpretation enquiry.

**Table 3 Information required for *QECM* interpretation enquiries**

Information category	Required information
<i>Customer and premises</i>	<i>Customer</i> name
	<i>Premises</i> address(s)
	<i>NMI</i> (s)
Licenced Electrical Worker, electrical consultant or <i>Engineer</i>	Name
	Phone number
	Email address
<i>DNISP</i> reference	Any relevant <i>DNISP</i> document reference
Enquiry	Details of the nature of the enquiry

### 1.6.4 Interpretation enquiry response timeframes

A Licenced Electrical Worker should account for adequate time for the *DNISP* to provide a response to an interpretation enquiry. Interpretation enquiries should be responded to in the timeframes in Table 4.

**Table 4 Interpretation enquiry response timeframes**

Type of interpretation enquiry	Timeframe for response <sup>1</sup>
General (No non-compliance notification issued)	10 business days

Note 1: Timeframes may vary when the *DNISP* experiences high volumes of enquiries or for complex enquiries which require specific Subject Matter Expert (SME) advice. The *DNISP* will provide advice if it is anticipated that these timeframes may be exceeded.

Note 2: A Electricity Defect Report is used where non-compliances are observed at a *Proponent's premises*. The method of notice for a non-compliance may vary based on the non-compliance and the manner in which it is identified.

## 1.7 Document management

### 1.7.1 Alterations

This *manual* may be updated from time to time. Please refer to the latest version available on the *DNISP's* website. Website details are available in Appendix N.

### 1.7.2 Addendums

Addendums to this version of the *QECM* may be published by the *DNISP* in relation to specific topics.

An addendum shall be considered effective:

- (a) from the published date; or
- (b) a specified date indicated on the *QECM* addendum.

### 1.7.3 Requesting amendments

Requests made for amendments to the *QECM* shall be submitted as follows:

- (a) be in writing and sent to the email address provided for 'QECM amendment requests' in Appendix N; and
- (b) indicate the specific clause(s) an amendment is being requested for, where relevant; and
- (c) provide detail of the suggested changes to the *QECM*.

An acknowledgement of receipt of the amendment request will be provided within 10 working days from receipt of the written request. Amendment requests will be reviewed and considered for inclusion in new versions of the *QECM*, alterations or addendums.

## 1.8 Drawings, figures and tables

### 1.8.1 Drawings

Drawings for this *manual* are located in Appendix A and a list of the drawings is shown in Table 5. Drawings may be referenced in more than one clause of this *manual*.

# Queensland Electricity Connection Manual

Table 5 List of *QECM* drawings

Number	Drawing name
QCD05-01	<i>Generation signalling device for single inverter - small IES</i>
QCD05-02	Multiple <i>generation signalling devices for multiple inverters – small IES</i>
QCD05-03	<i>Generation signalling device with demand response site controller for multiple inverters – small IES</i>
QCD05-04	<i>Generation signalling device for single inverter – LV IES</i>
QCD05-05	Multiple <i>generation signalling devices for multiple inverters – LV IES</i>
QCD05-06	<i>Generation signalling device with demand response site controller for multiple inverters – hardwired connection to LV IES</i>
QCD05-07	<i>Generation signalling device with demand response site controller for multiple inverters – wireless connection to LV IES</i>
QCD05-08	Peak Smart Air Conditioner Connection
QCD06-01	Overhead service clearances from ground
QCD06-02	Overhead service clearances from structures
QCD06-03	Overhead Exclusion Zone
QCD06-04	Overhead 25/35 mm <sup>2</sup> service attachment to fascia (1.0 kN) - connection and bridging details
QCD06-05	Overhead 50/95 mm <sup>2</sup> service attachment to fascia (3.5 kN) - connection and bridging details
QCD06-06	Overhead 50/95 mm <sup>2</sup> service attachment mains box connection details
QCD06-07	Overhead 25/35 mm <sup>2</sup> service attachment to raiser bracket (1.0 kN) - connection and bridging details
QCD06-08	Overhead 50/95 mm <sup>2</sup> service attachment to raiser bracket (3.5 kN) - connection and bridging details
QCD06-09	Overhead 25/35 mm <sup>2</sup> service attachment to property pole (1.0 kN) - connection and bridging details
QCD06-10	Overhead 50/95 mm <sup>2</sup> service attachment to property pole (3.5 kN) - connection and bridging details
QCD06-11	Overhead service attachment to steel property pole (1.0 kN and 3.5 kN SWL options) - General arrangement
QCD06-12	Steel property pole (1.0 kN SWL) - Fabrication details
QCD06-13	Steel property pole (1.0 kN SWL) - Foundation construction details
QCD06-14	Steel property pole (3.5 kN SWL) - Fabrication details
QCD06-15	Steel property pole (3.5 kN SWL) - Foundation construction details
QCD06-16	<i>Consumer mains on DNSP pole</i>
QCD06-17	<i>OH service attachment to builders temporary service pole (1.0 kN SWL) - General arrangement</i>

Number	Drawing name
QCD06-18	Builders temporary service pole (1.0 kN SWL) - Fabrication and construction details (page 1 of 2)
QCD06-19	Builders temporary service pole (1.0 kN SWL) - Fabrication and construction details (page 2 of 2)
QCD07-01	Underground Connection to an Interim Structure During Construction General Arrangement
QCD08-01	Basic active management via <i>Network Device</i> for electric vehicle supply equipment wiring diagram
QCD09-01	Master keyed utility access lock details
QCD09-02	Acceptable locations of <i>meter board</i> - Single domestic (1 of 2)
QCD09-03	Acceptable locations of <i>meter board</i> - Single domestic (2 of 2)
QCD09-04	Acceptable locations of <i>meter board</i> - Community title
QCD09-05	Small Subdivision Supply Arrangements
QCD09-06	Bollard position for <i>meter board</i> located on property pole
QCD10-01	Metering Isolation Link - General dimensions
QCD10-02	AF receiver - Drilling details for cable access
QCD10-03	Direct connected and CT metering - multiple <i>Customer</i> metering arrangement on shared service (1 of 2)
QCD10-04	Direct connected and CT metering - multiple <i>Customer</i> metering arrangement on shared service (2 of 2)
QCD10-05	CT metering - typical meter panel layout and arrangement
QCD10-06	Single-phase service direct connected metering: Primary and secondary tariff wiring diagram
QCD10-07	Multiple installations three-phase service, single-phase supply direct connected metering: Primary and secondary tariff wiring diagram
QCD10-08	Duplex two-phase service direct connected metering: Primary and secondary tariff wiring diagram
QCD10-09	Direct connected metering three-phase primary and secondary tariff wiring diagram
QCD10-10	Three-phase service direct connected metering: Primary and secondary tariff wiring diagram
QCD10-11	Single-phase service direct connected metering: Primary and controlled tariff with electric vehicle wiring diagram
QCD10-12	Three-phase service CT metering: Primary and secondary tariff wiring diagram
QCD10-13	Three-phase service CT metering: Primary load control tariff wiring diagram

## 1.8.2 Figures

A list of figures for this *manual* is shown in Table 6.

**Table 6 List of QECM figures**

Number	Figure description
Figure 1	General Arrangement of Multiple <i>DNISP service point</i> with bus-tie interlocking
Figure 2	General Arrangement of Multiple <i>DNISP service point</i> with no bus-tie
Figure 3	Typical <i>UG LV service pillar</i>
Figure 4	Safety Warning – Asbestos in <i>meter board</i> enclosures and meter panels
Figure 5	Meter isolating device <i>CB</i> label
Figure 6	Meter isolating link fuse warning label
Figure 7	<i>Controlled supply</i> meter label for dedicated GPO
Figure 8	Ergon Energy Network <i>isolated network</i> supply area map
Figure 9	<i>DNISP service area</i> map

### 1.8.3 Tables

A list of tables in this *manual* is shown in Table 7.

**Table 7 List of *QECM* tables**

Number	Table description
Table 1	<i>DNISP</i> requirements for working near overhead and underground electric lines
Table 2	Common connection activities for stakeholder interaction diagrams
Table 3	Information required for <i>QECM</i> interpretation enquiries
Table 4	Interpretation enquiry response timeframes
Table 5	List of <i>QECM</i> drawings
Table 6	List of <i>QECM</i> figures
Table 7	List of <i>QECM</i> tables
Table 8	Application processes for connection activities
Table 9	<i>Network tariff</i> structure
Table 10	<i>Authorised person</i> application process
Table 11	Activities requiring approval
Table 12	Protected item categories and criteria
Table 13	Engineering disciplines for design and commissioning activities
Table 14	Requirements for options for additional <i>LV DNISP service point</i>
Table 15	Determining phase requirements for a <i>DNISP service point</i> connected to the <i>distribution system</i>
Table 16	Demand Connection Offer types per <i>Customer</i> type
Table 17	Capacity Connection Offer types per <i>Customer</i> type
Table 18	<i>DNISP service point</i> provision based on <i>community title</i> scheme at a <i>premises</i>

# Queensland Electricity Connection Manual



Part of Energy Queensland

Number	Table description
Table 19	Bus-tie interlocking arrangement requirements
Table 20	<i>Active device management</i> classification
Table 21	<i>OH DNSP service point</i> options for connection to <i>premises</i>
Table 22	Maximum length of an <i>OH service line</i>
Table 23	Unsuitable routes or <i>point of attachment</i> locations for <i>OH service lines</i>
Table 24	Standard <i>OH service line</i> cables used by each <i>DNSP</i>
Table 25	<i>OH point of attachment</i> and <i>connection point</i> options
Table 26	<i>Safe working loads (SWL)</i> applying to the <i>point of attachment</i> for <i>OH service lines</i>
Table 27	Attachment options for <i>OH service lines</i> with <i>safe working loads (SWL)</i> of 1.0 kN and 3.5 kN
Table 28	Approved <i>OH service point</i> attachment structure <i>prescriptive standard</i> drawings
Table 29	Suitable sizes UV resistant insulated enclosures
Table 30	Soil quality
Table 31	<i>UG DNSP service point</i> options for connection to <i>premises</i>
Table 32	Unsuitable routes or <i>point of attachment</i> locations for <i>UG DNSP service point</i>
Table 33	<i>OH point of attachment</i> and <i>connection point</i> options
Table 34	<i>UG pillar</i> types and ratings of <i>DNSP service point</i> connection
Table 35	<i>LV</i> supply voltage
Table 36	<i>LV</i> voltage drop and voltage rise for <i>LV electrical installations</i> at a <i>premises</i>
Table 37	Maximum three-phase fault currents on <i>LV</i> terminals of a distribution transformer
Table 38	Power factor performance standard
Table 39	<i>Active device management</i> options
Table 40	<i>GSD</i> for individual inverter
Table 41	<i>GSD</i> for multiple inverters
Table 42	<i>GSD</i> with <i>demand response site controller</i> for multiple inverters
Table 43	<i>Dynamic EVSE</i> limits
Table 44	Switched load equipment current limits
Table 45	Single phase motors
Table 46	Three phase motors 400 V
Table 47	<i>EG</i> connection standards
Table 48	Metering types

Number	Table description
Table 49	<i>Meter board</i> location requirements for specific <i>premises</i> types
Table 50	Minimum distance for locating a <i>meter board</i> from a driveway edge or trafficable area
Table 51	Unsuitable locations for a <i>meter board</i> and associated equipment
Table 52	<i>Meter board</i> location requirements for <i>domestic premises</i>
Table 53	<i>Meter board</i> location requirements for <i>non-domestic premises</i>
Table 54	<i>Meter board</i> location for <i>community title</i> scheme
Table 55	Meter and <i>network device</i> equipment spacing requirements
Table 56	DNISP audio-frequency signals for load control
Table 57	<i>Dynamic</i> operation criteria
Table 58	Minimum information required for activities requiring approval
Table 59	<i>Dynamic</i> monitoring information via CSIP-AUS
Table 60	<i>Dynamic</i> control functions via CSIP-AUS
Table 61	LV connection direct current metering check sheet for <i>Electrical Contractors</i>
Table 62	LV connection current transformer metering check sheet for <i>Electrical Contractors</i>
Table 63	Maximum permitted rating of AC motors in <i>isolated</i> networks
Table 64	Definitions for specification for metallic enclosures for Direct Connected <i>metering installations</i>
Table 65	Type A and Type B enclosure and meter panel dimensions
Table 66	<i>Network device</i> and metering enclosure materials for construction
Table 67	Eligible equipment for connection to a primary load control tariffs
Table 68	Eligible equipment for connection to a secondary load control tariffs
Table 69	Alterations of existing connections
Table 70	Card operated metering areas
Table 71	DNISP contact details

## 2 Definitions and abbreviations

### 2.1 Definitions<sup>2</sup>

Words and terms defined in the definitions are identified within the *manual* by italicising.

---

<sup>2</sup> Terms not otherwise defined in this document, have the meaning given to that term in the *NER*, National Energy Retail Law, legislation or AS/NZS 3000.

# Queensland Electricity Connection Manual



Part of Energy Queensland

Term	Definition
accredited auditor	Means a person holding an appointment as an accredited auditor under part 10, division 3 of the Electrical Safety Act 2002 <sup>3</sup> .
active device management	The coordinated communication, operation and functioning of <i>Customer electrical equipment</i> , devices, or <i>EG</i> systems, to actively manage demand, <i>imports</i> , generation or <i>exports</i> to optimise capability or opportunity to access <i>distribution system</i> services and create value from <i>Customer</i> energy resources.
audio frequency (AF) receiver	See <i>network device</i>
authorised person	For work near an electrical line, means a person who has enough technical knowledge and experience to do work that involves being near to the electrical line; and has been approved by the person in control of the electrical line ( <i>electricity entity</i> ) to do work near to the electrical line.
authorised person (electrical)	An Electrical Mechanic or Electrical Linesperson (holding current Queensland Licence) working on behalf of an <i>Electrical Contractor</i> and accredited with the <i>electricity entity</i> who is permitted to remove and replace <i>LV</i> service fuse(s) when isolation of <i>Customer LV service line</i> is required to eliminate the exclusion zone around the <i>LV service line</i> , or to work on the <i>Customer's</i> mains and / or switchboard.
break-before-make	<i>Break-before-make</i> operation is used in a switch that is configured to break (open) the first set of contacts before engaging (closing) the new contacts.
building format plan	A building format plan of survey defines land using the structural elements of a building, including, for example, floors, walls and ceilings.
child connection point	The agreed point of supply between an <i>embedded network</i> and an <i>electrical installation</i> , generating unit or other network connected to <i>that embedded network</i> , for which a Market Participant, as defined under the National Electricity Rules, is, or proposes to be, financially responsible.
common property	<i>Common property</i> means so much of a parcel as from time to time is not comprised in any lot. Refer to Building Units and Group Titles Act 1980 (Qld).
community title	A subdivision of land in which individual lots do not necessarily have immediate access to a dedicated road serve and which comply with the Body Corporate and Community Management Act (Qld).
connection assets	Those components of a <i>distribution system</i> which are used to provide <i>connection services</i> .
connection contract	A contract formed by the making and acceptance of a connection offer under the <i>NER</i> .
connection point	An agreed point of supply established between the DNSP's <i>distribution system</i> and a <i>Proponent's premises</i> .
connection policy	The DNSP's <i>connection policy</i> provides an outline of connection services, when connection charges may be payable by <i>Customers</i> and how those charges are calculated.
consumer mains	The conductors between the <i>point of attachment</i> and the main switchboard.

<sup>3</sup> Further information may be obtained from [www.worksafe.qld.gov.au](http://www.worksafe.qld.gov.au).

# Queensland Electricity Connection Manual



Part of Energy Queensland

Term	Definition
controlled load, controlled supply	Those loads that are wired separately from other appliances, are controlled by means of frequency injection receiver or time clock and are separately metered from the remaining load at the metering point. Information on controlled loads is available in Appendix I.
<i>Customer</i>	A person, including a relevant body corporate, who receives, or wants to receive, a supply of electricity for a <i>premises</i> from an <i>electricity entity</i> or special approval holder.
demand response	The automated alteration of a mode of operation for <i>electrical equipment</i> or an inverter in response to an initiating signal originating from or defined by the Distributor.
demand response site controller (DRSC)	A device which interprets the operational instructions from the GSD and operates the <i>emergency backstop mechanism</i> for multiple inverters at a <i>premises</i> .
distribution network	A <i>network</i> which is not a <i>transmission network</i> . This <i>manual</i> refers to the <i>low voltage</i> and <i>high voltage</i> portions of the <i>distribution network</i> .
Distribution Network Service Provider (or DNSP)	A person who engages in the activity of owning, controlling, or operating a <i>distribution system</i> . Depending on the context means either Energex (who owns and operates the <i>distribution system</i> in South East Queensland) or Ergon Energy Network (who owns and operates the <i>distribution system</i> in the remainder of Queensland).
distribution system	A <i>distribution network</i> , together with the <i>connection assets</i> associated with the <i>distribution network</i> , which is connected to another <i>transmission system</i> or <i>distribution system</i> . The relevant <i>low voltage</i> or <i>high voltage</i> section of the <i>distribution system</i> owned and operated by the DNSP to which the <i>electrical installation</i> is, or will be, connected.
DNSP service point	The point the DNSP's <i>distribution system</i> terminates at the <i>Proponent's</i> consumer's mains to provide a connection.
domestic	Private dwelling or living unit
dynamic	<i>Dynamic active device management</i> involves the publishing of variable <i>dynamic operating envelope</i> (DOE) settings by the DNSP for the <i>Proponent's</i> DNSP <i>service point</i> for CSIP-AUS.
dynamic operating envelopes (or DOE(s))	<i>Dynamic operating envelopes</i> (DOE) are where <i>electrical equipment</i> or <i>EG system</i> setting limits, such as <i>import</i> and <i>export</i> limits, can vary over time and location
easement	A legal right to cross or otherwise use someone else's land for a specified purpose, where that right is registered on the title for the relevant land. An easement in favour of the DNSP must be on terms acceptable to the DNSP (known as an electrical services easement).
Electrical Contractor	A person licenced under the Electrical Safety Act 2002 (Qld) to conduct a business or undertaking that includes the performance of electrical work.
electrical equipment	Any equipment considered <i>electrical equipment</i> in Chapter 1, Section 14 of the Electricity Act 2002 (Qld).

# Queensland Electricity Connection Manual



Part of Energy Queensland

Term	Definition
electrical installation	A group of items of <i>electrical equipment</i> that: <ul style="list-style-type: none"> <li>• are permanently electrically connected together; and</li> <li>• can be supplied with electricity from the works of an <i>electricity entity</i> or from a generating source; and</li> <li>• do not include items that are works of an <i>electricity entity</i>.</li> </ul>
Electrical Works Request (EWR)	The request from the <i>Customer's Electrical Contractor</i> to a <i>DNSP</i> to perform a distribution service e.g. the <i>DNSP's</i> Form 2.
electricity entity	An entity that is a participant in the electricity industry as per Chapter 2, Part 1 of the Electricity Act 1994 (Qld). The following entities are the participants in the electricity industry: <ul style="list-style-type: none"> <li>• generation entities;</li> <li>• transmission entities;</li> <li>• distribution entities.</li> </ul>
embedded generating system(s) (or <i>EG</i> system(s))	One or more <i>embedded generating units</i> and auxiliary equipment that are interconnected with the <i>distribution network</i> .
embedded generating units(s) (or <i>EG</i> units(s))	A <i>generating unit</i> connected within a <i>distribution system</i> and not having direct access to the <i>transmission network</i> .
embedded network	A <i>distribution system</i> , connected at a parent connection point to a <i>distribution system</i> that forms part of the national grid, and which is owned, controlled or operated by a person who is not a <i>DNSP</i> .
emergency backstop mechanism	Involves the use of <i>generation signalling devices</i> to provide a <i>demand response</i> that causes an <i>IES</i> to temporarily cease or reduce generation in emergency contingency events within the power system. The mechanism may be called upon to respond to a direction by <i>AEMO</i> issued in accordance with the <i>NEL</i> .
energy laws	Relevant laws relating to the subject matter of this <i>manual</i> .
energy storage system (or <i>ESS</i> )	A system comprising one or more batteries that store electricity and that can discharge the electricity to loads.
engineer	A person who is: <ul style="list-style-type: none"> <li>• a registered professional <i>engineer</i> under the Professional Engineers Act 2002 (RPEQ); and</li> <li>• is competent to perform the task.</li> </ul>
export	Net electricity that is fed into the <i>distribution system</i> through the <i>connection point</i> .
extra-low voltage	A voltage of no more than 50V a.c. or 120V ripple free d.c.
generating unit	The plant used in the production of electricity and all related equipment essential to its functioning as a single entity.
<i>generation signalling device</i> ( <i>GSD</i> )	A <i>DRED</i> providing functionalities and capabilities to achieve <i>demand response</i> , which satisfies the requirements of AS/NZS 4755.1 <sup>4</sup> .

<sup>4</sup> A list of Approved *GSD* can be found at Energex at: <https://www.energex.com.au/home/our-services/connections/residential-and-commercial-connections/solar-and-lv-generation-connections/emergency-backstop-mechanism>

# Queensland Electricity Connection Manual



Part of Energy Queensland

Term	Definition
high voltage (or HV)	Any voltage greater than 1, 000 V a.c.
import	Net electricity that is supplied via the <i>distribution system</i> through the <i>connection point</i> .
isolated network	Refers to the small remote electricity <i>distribution systems</i> operated by Ergon Energy Network that are not connected to the national electricity grid and are supplied via a dedicated power station.
large Customer	As per <i>tariff class</i> assignment process for <i>Customers</i> with consumption greater than 100 MWh per year
low voltage (or LV)	A voltage greater than <i>extra-low voltage</i> and of no more than 1,000 V a.c. or 1,500 V d.c.
manual	This document that is entitled "Queensland Electricity Connection Manual".
meter board	A switchboard housing <i>network devices</i> and metering equipment, installed in compliance with this <i>manual</i> .
Metering Coordinator	A person who is registered by AEMO as a <i>Metering Coordinator</i> under Chapter 2 of the <i>NER</i> to engage in the coordination and provision of metering services at a <i>connection point</i> in accordance with Chapter 7 of the <i>NER</i> .
Metering Data Provider	A person who meets the requirements listed in schedule 7.3 of the <i>NER</i> and has been accredited and registered by AEMO to undertake the collection, processing, storage and delivery of metering data and the management of <i>NMI Standing Data</i> .
metering installation	The assembly of components including the instrument transformer, if any, measurement element(s) and processes, if any, recording and display equipment, communications interface, if any, that are controlled for the purpose of metrology and which lie between the <i>metering point(s)</i> and the point at or near the <i>metering point(s)</i> where the energy data is made available for collection.
Metering Provider (MP)	A person who meets the requirements listed in schedule 7.2 of the <i>NER</i> and has been accredited by and registered by AEMO to undertake the provision, installation and maintenance of <i>metering installations</i> . Note: The <i>DNISP</i> is the <i>Metering Provider</i> in areas not connected to the <i>NEM</i> .
National Metering Identifier (NMI)	A <i>National Metering Identifier (NMI)</i> is a unique national identifier that relates to the <i>metering installation</i> at a <i>Customer's premises</i> .
network device	Apparatus or equipment that: (a) enables a <i>DNISP</i> to monitor, operate or control the network for the purposes of providing network services, which may include switching devices, measurement equipment and control equipment; and (b) is located at or adjacent to a <i>metering installation</i> at the <i>connection point</i> of a <i>Customer</i> ; and (c) does not have the capability to generate electricity.
network tariffs	The set of charges applied by the <i>DNISP</i> to a <i>Retailer</i> based on a <i>Customer's</i> respective billing period. A tariff consists of one or more charging parameters that comprise the total tariff rate.
non-domestic	installations include but are not limited to individual or multiple commercial or industrial <i>electrical installations</i> or portions of or mixed commercial and industrial installations.

# Queensland Electricity Connection Manual



Part of Energy Queensland

Term	Definition
Non-registered embedded generator	A non-registered embedded generator as defined under the National Electricity Rules.
off-grid	A <i>generating unit</i> which can supply a <i>Customer</i> load as back-up, also known as “non-parallel”. In this circumstance, the <i>generating unit</i> is not connected in <i>parallel</i> and does not synchronise with the <i>distribution system</i> . Loads shall be isolated from the <i>distribution network</i> when being supplied from the non-parallel <i>generating unit</i> .
parallel (or grid connected)	This is where the <i>EG unit</i> is configured such that the <i>EG unit</i> and the <i>distribution system</i> may operate in parallel from time to time (even if this is a very short period of time).
parcel	means the land comprised in a plan. Refer to Building Units and Group Titles Act 1980 (Qld).
plan	means a building units plan or a group titles plan. Refer to Building Units and Group Titles Act 1980 (Qld).
point of attachment	The point at which: (a) aerial conductors of a <i>service line</i> or aerial <i>consumer mains</i> are physically terminated on a <i>Customer’s</i> structure for an <i>OH DNSP service point</i> ; or <i>consumer mains</i> are physically terminated to the <i>DNSP connection assets</i> at an <i>UG DNSP service point</i> .
point of entry	The point at which the <i>consumer mains</i> or the underground service cable enters a structure.
pre-approved unmetered supply device	means one or more of the following devices as set out in the <i>Proponent’s connection contract</i> : (a) watchman light; or (b) device listed on our website as a <i>pre-approved unmetered supply device</i> . For the avoidance of doubt, this term excludes street lights
premises	Means any land (whether a single block or multiple contiguous blocks), building(s) (whether whole or part), and structure(s) (or adjuncts thereto) that are owned, occupied or controlled by the <i>Proponent</i> in the vicinity of the proposed connection and which can reasonably be considered to be part of a single overarching operation.
prescriptive standard	A <i>prescriptive standard</i> is a document that states procedures or criteria for carrying out an engineering service, the application of which does not require advanced scientifically-based calculations.
professional engineering service	An engineering service that requires, or is based on, the application of engineering principles and data to a design, or to a construction, commissioning, production, operation or maintenance activity, relating to engineering, and does not include an engineering service that is provided only in accordance with a <i>prescriptive standard</i> (see schedule 2 Professional Engineers Act 2002).
Proponent	The retail <i>Customer</i> that is the relevant owner, operator, or controller of loads or an <i>embedded generating system</i> connected to an <i>electrical installation</i> (or their agent).

# Queensland Electricity Connection Manual



Part of Energy Queensland

Term	Definition
reactive power	The rate at which reactive energy is transferred, which is a necessary part of an alternating current system containing inductive and capacitive components, as it regulates the voltage within the system. <i>Reactive Power</i> is measured in vars within the scope of this Standard.
Retailer	A person who holds a retail authority to sell electricity and retail services (a 'retail authority' authorises its holder to provide <i>Customer</i> retail services under the terms of the authority).
rural	A <i>rural</i> area is defined as one with a density of less than 5 lots per hectare (i.e. would generally have a dedicated supply transformer). Note: This definition is only applicable for the Ergon Energy Network distribution area.
safe working load ( or SWL)	the mass or force that a piece of equipment can safely use to lift or suspend, a mass without fear of breaking.
service line	An electric line that- (a) forms part of the works of an <i>electricity entity</i> ; and (b) connects consumer terminals to: (i) other parts of the works of the <i>electricity entity</i> ; or (ii) the works of another <i>electricity entity</i> . As per Schedule 9 of the Electricity Regulation 2006 (Qld).
single wire earth return (or SWER)	Parts of the electrical <i>high voltage distribution network</i> that use a single live conductor with the earth as the return current path. All <i>premises</i> are supplied at LV either as single-phase or split-phase electric power.
small Customer	As per <i>tariff class</i> assignment process for <i>Customers</i> with consumption less than 100 MWh per year.
small IES	Micro-embedded generators of the kind contemplated by Australian Standard AS/NZS 4777 (Grid connection of energy system via inverters) up to 30 kVA for which a <i>small IES EG</i> connection is appropriate.
Split-phase SWER	A split-phase connection is a two-phase supply provided off a single SWER transformer.
suitable mains connection box	A mains connection box that is deemed to be compliant with the <i>DNISP's</i> technical specifications in clause 6.7.4 of this manual.
tariff class	A class of <i>Customers</i> for one or more direct control services who are subject to a particular tariff or particular tariffs (as per chapter 10 of the <i>NER</i> ).
two element meter	A single phase two element device which includes both metering and load switching within one meter.
unmetered supply	A <i>Type 7 metering installation</i> classification ( <i>NER</i> ) where a <i>metering installation</i> does not require a meter to measure the flow of electricity in a power conductor and accordingly there is a requirement to determine by other means the energy data that is deemed to flow in the power conductor and managed by the relevant distribution entity.
urban	A residential area with a system of street lighting.

# Queensland Electricity Connection Manual



Part of Energy Queensland

## 2.2 Abbreviations

Term, abbreviation or acronym	Definition
ABS	Air Break Switch
AEMO	Australian Energy Market Operator
AER	Australian Energy Regulator
AFLC	Audio Frequency Load Control
AS/NZS	A jointly developed Australian and New Zealand Standard
AS	Australian Standard
C & I	Commercial and Industrial
CB	Circuit Breaker
CBD	Central Business District
CMIG	Competitive Metering Industry Group
CSIP	Common Smart Inverter Profile
BYD	Before You Dig
DNSP	<i>Distribution Network Service Provider</i>
DRED	Demand Response Enabling Device
ECMM	Electricity Connection and Metering Manual
ESS	Energy Storage System
EWR	Electrical Works Request
EVSE	Electric Vehicle Supply Equipment
GSD	<i>Generation Signalling Device</i>
IEC	International Electrotechnical Commission
IES	Inverter Energy System
IPC	Insulation Piercing Connector
MEN	Multiple Earthed Neutral
MIL	Metering Isolation Link
MIR	Metering Installation Requirements
NATA	The National Association of Testing Authorities
NEL	National Electricity Law
NEM	National Electricity Market
NER	National Electricity Rules
NMI	National Metering Identifier
OH	Overhead
PV	Photovoltaic
QECM	Queensland Electricity Connection Manual
QEMM	Queensland Electricity Metering Manual (withdrawn 2023)

Term, abbreviation or acronym	Definition
RMU	Ring Main Unit
RPEQ	Registered Professional <i>Engineer</i> of Queensland
SOR	Service Order Request
SEP2	IEEE 2030.5 <i>Standard for Smart Energy Profile Application Protocol</i>
SWER	Single Wire Earth Return
SWL	Safe Working Load
UG	Underground
V2G	Vehicle to Grid

## 2.3 Terminology

### 2.3.1 Application of requirements

In this *manual*:

- (a) the word "shall" indicates a mandatory requirement that the *Proponent* must comply with;
- (b) the word "should" indicates a recommended requirement that will not be mandatorily imposed on the *Proponent*; and
- (c) the word "may" indicates a requirement that the *DNSP* may determine the *Proponent* must comply with.

## 3 Relevant rules, regulations, standards and codes

### 3.1 Standards and codes

There are a range of applicable standards and industry codes which define connection types and applicable requirements, as set out below.

In the event of any inconsistency between:

- (a) an applicable Australian and international standards and industry codes (except for legislated industry codes); and
- (b) this *manual*,

this *manual* will prevail.

#### 3.1.1 DNSP documents

A copy of the latest version of this *manual* may be obtained by searching for *QECM* from the following websites: <https://www.energex.com.au/> or <https://www.ergon.com.au/network/>

Other relevant *DNSP* documents are available on *DNSP* websites and include:

Document number	Document name	Document type
	Energex Connection Policy 2020-2025	Reference
	Energex Pricing Proposal	Reference
	Ergon Energy Connection Policy 2020-2025	Reference
	Ergon Energy Pricing Proposal	Reference
	Ergon Energy Underground Construction Manual	Reference

# Queensland Electricity Connection Manual



Manual 00305	Energex Underground Distribution Construction Manual	Reference
Manual 00768	Major Customer Connection Manual	Reference
Manual 01812	Queensland Electricity Metering Manual (Withdrawn)	Reference
PW000202R114	Guidelines for Electrical installations at Isolated Systems	Reference
STNW1170	Standard for Small IES Connections	Standard
STNW1174	Standard for LV EG Connections	Standard
STNW1175	Standard for HV EG Connections	Standard
STNW3510	Dynamic Standard for Small IES Connections	Standard
STNW3511	Dynamic Standard for LV EG Connections	Standard
STNW3522	Standard for Major Customer Connections	Standard

## 3.1.2 Australian standards

Document number	Document name	Document type
AS 1111.1	ISO metric hexagon bolts and screws - Product grade C, Part 1: Bolts	Australian Standard
AS/NZS 1163	Cold-formed structural steel hollow sections	AU/NZ Joint Standard
AS/NZS 1269.1	Occupational noise management, Part 1: Measurement and assessment of noise immission and exposure	AU/NZ Joint Standard
AS 1275	Metric screw threads for fasteners	Australian Standard
AS 1319	Safety signs for the occupational environment	Australian Standard
AS 1397	Continuous hot-dip metallic coated steel sheet and strip - Coatings of zinc and zinc alloyed with aluminium and magnesium	Australian Standard
AS/NZS 1554.1	Structural steel welding, Part 1: Welding of steel structures	AU/NZ Joint Standard
AS 1657	Fixed platforms, walkways, stairways and ladders - Design, construction and installation	Australian Standard
AS 2067	Substations and high voltage installations exceeding 1 kV a.c.	Australian Standard
AS/NZS 3000	Electrical Installations – Wiring Rules	AU/NZ Joint Standard
AS/NZS 3010	Electrical Installations – Generating sets	AU/NZ Joint Standard

# Queensland Electricity Connection Manual



Part of Energy Queensland

Document number	Document name	Document type
AS/NZS 3012	Electrical installations - Construction and demolition sites	AU/NZ Joint Standard
AS/NZS 3100	Approval and test specification – General requirements for electrical equipment	AU/NZ Joint Standard
AS/NZS 3560.1	Electric cables - Cross-linked polyethylene insulated - Aerial bundled - For working voltages up to and including 0.6/1(1.2) kV, Part 1: Aluminium conductors	AU/NZ Joint Standard
AS 3600	Concrete structures	Australian Standard
AS/NZS 3678	Structural steel - Hot-rolled plates, floorplates and slabs	AU/NZ Joint Standard
AS/NZS 3679.1	Structural steel, Part 1: Hot-rolled bars and sections	AU/NZ Joint Standard
AS 3818.11	Timber - Heavy structural products - Visually graded, Part 11: Utility poles	Australian Standard
AS/NZS 3820	Essential safety requirements for electrical equipment	AU/NZ Joint Standard
AS 4100	Steel structures	Australian Standard
AS/NZS 4417.2	Regulatory compliance mark for electrical and electronic equipment, Part 2: Specific requirements for particular regulatory applications	AU/NZ Joint Standard
AS 4645.1	Gas distribution networks, Part 1: Network management	Australian Standard
AS/NZS 4671	Steel for the reinforcement of concrete	AU/NZ Joint Standard
AS/NZS 4680	Hot-dip galvanized (zinc) coatings on fabricated ferrous articles	AU/NZ Joint Standard
AS 4741	Testing of connections to low voltage electricity networks	Australian Standards
AS/NZS 4777.1	Grid connection of energy systems via inverters Part 1: Installation requirements	AU/NZ Joint Standard
AS/NZS 4777.2	Grid connection of energy systems via inverters Part 2: Inverter requirements	AU/NZ Joint Standard
AS/NZS 5000.1	Electric cables - Polymeric insulated, Part 1: For working voltages up to and including 0.6/1 (1.2) kV	AU/NZ Joint Standard
AS/NZS 5033	Installation and Safety Requirements for Photovoltaic (PV) Arrays	AU/NZ Joint Standard

# Queensland Electricity Connection Manual



Part of Energy Queensland

Document number	Document name	Document type
AS/NZS 5139	Electrical Installations - Safety of battery systems for use with power conversion equipment	AU/NZ Joint Standard
AS/NZS 5601.1	Gas installations, Part 1: General installations	AU/NZ Joint Standard
AS IEC 60038	Standard Voltages	AU adoption of IEC Standard
AS/NZS IEC 60079.10.1	Explosive atmospheres, Part 10.1: Classification of areas - Explosive gas atmospheres	AU/NZ Joint Standard
AS 600974.6 <sup>5</sup>	Arc welding equipment, Part 6: Limited duty portable arc welding and allied process power sources	Australian Standard
AS 60529	Degrees of protection provided by enclosures (IP Code)	Australian Standard
AS/NZS IEC 60947	Low-voltage switchgear and controlgear (multiple parts)	AU/NZ Joint Standard
AS/NZS 61000	Electromagnetic compatibility (EMC), (multiple parts)	AU/NZ Joint Standard
AS 61869	Instrument transformers (multiple parts)	Australian Standard
AS IEC 62196.2	Plugs, socket-outlets, vehicle connectors and vehicle inlets - Conductive charging of electric vehicles, Part 2: Dimensional compatibility and interchangeability requirements for a.c. pin and contact-tube accessories	AU adoption of IEC Standard

### 3.1.3 International standards

Document number	Document name	Document type
CSIP	IEEE 2030.5 Common California IOU Rule 21 Implementation Guide for Smart Inverters	International Standard
CSIP-AUS	Common Smart Inverter Profile - Australia	Australian guide
IEC 60269-1	Low-voltage fuses — Part 1: General requirements	International Standard
IEEE 2030.5 (or SEP2)	2030.5-2018 - IEEE Standard for Smart Energy Profile Application Protocol	International Standard

<sup>5</sup> For compliance requirements see: <https://www.eess.gov.au/wp-content/uploads/2021/04/21-040-Standard-to-be-used-to-test-and-certify-an-Arc-Welding-Machine.pdf>

## 3.1.4 Referenced Documents

Document number	Document name	Document type
MIR	Metering installation Requirements	Competitive Metering Industry Group

## 3.2 Legislation and regulation

Set out below is a list of applicable legislation and regulations (which may be amended, replaced, repealed or have further instruments enacted from time to time). This list is focused on legislation and regulations directly related to electricity law, markets and safety and does not seek to preclude any other legislation or regulations which may apply for a Proponent undertaking a connection activity under this *manual*.

In the event of any inconsistency between:

- (a) any applicable legislation and regulation; and
- (b) this *manual*,

the legislation and regulations will prevail.

Document name	Document type
<i>Electricity Act 1994</i> (Qld)	Legislation
<i>Electricity Regulation 2006</i> (Qld)	Regulation
<i>Electricity Distribution Network Code</i> (Qld)	Regulation
<i>Electrical Safety Act 2002</i> (Qld)	Legislation
<i>Electrical Safety Regulation 2013</i> (Qld)	Regulation
Electrical Safety Code of Practice 2020 – Working near overhead and underground electric lines	Regulation
Electrical Safety Code of Practice 2020 – Works	Regulation
<i>Electricity - National Scheme (Queensland) Act 1997</i> (Qld)	Legislation
Metrology Procedure: Part A National Electricity Market	Regulation
National Electricity (Queensland) Law, as defined in the <i>Electricity - National Scheme (Queensland) Act 1997</i> (Qld)	Regulation

# Queensland Electricity Connection Manual



Part of Energy Queensland

Document name	Document type
<i>National Energy Retail Law (Queensland) Act 2014 (Qld)</i>	Legislation
National Energy Retail Law (Queensland), as defined in the <i>National Energy Retail Law (Queensland) Act 2014 (Qld)</i>	Regulation
National Electricity Rules	Regulation
<i>Professional Engineers Act 2002 (Qld)</i>	Legislation
<i>Workplace Health and Safety Act 2011</i>	Legislation
<i>Workplace Health and Safety Regulation 2011</i>	Regulation
<i>Construction and Operation of Solar Farms Code of Practice 2019</i>	Regulation
<i>Electrical Safety Code of Practice 2021—Managing Electrical Risks in the Workplace</i>	Regulation
<i>Electrical Safety Code of Practice 2020—Electrical Equipment Rural Industry</i>	Regulation

## 4 Connection activities

### 4.1 Connection applications

#### 4.1.1 General

- (a) A *Proponent* shall not undertake the following activities without following *DNSP*'s relevant application process and obtaining prior written consent from the *DNSP*:
  - (i) Connect to the *distribution system*.
  - (ii) Modify the connected system and associated equipment, including but not limited to the installation of new equipment.
- (b) The *Proponent* shall ensure the following obligations are met in regard to connection activities:
  - (i) Comply with this *manual* and the terms and conditions of the relevant *connection contract*.
  - (ii) Ensure that all *professional engineering services* are supervised and certified by a Registered Professional Engineer of Queensland (*RPEQ*).
  - (iii) Ensure design, construction, installation, commissioning and operation of the *electrical installation* and *metering installation* connection to the *distribution system*, complies with the relevant *energy laws*, regulations, standards, manuals, guidelines and codes of practice as they apply in Queensland.

#### 4.1.2 Application process

The connection application process for the connections referred to in this *manual* are outlined in the *NER* and can be found on both *DNSP*'s websites:

**Table 8 Application processes for connection activities**

<i>DNSP</i>	Connection application processes
Energex	<a href="https://www.energex.com.au/home/our-services/connections/">https://www.energex.com.au/home/our-services/connections/</a>
Ergon Energy Network	<a href="https://www.ergon.com.au/network/connections/">https://www.ergon.com.au/network/connections/</a>

The application process for connection activities may include, but not be limited to, any of the following attributes:

- (a) Be subject to fees and charges (see clause 4.1.4).
- (b) Include stages and timeframes for completion of activities.
- (c) Require submission of relevant documentation.
- (d) Require a *Proponent* to make applications or be provided with approvals, licences or similar from another agency, prior to, during or as a result of an application process.
- (e) Require technical studies by the *Proponent*, the *DNSP* or other agencies.
- (f) Require *DNSP* works which could include the installation of *network devices* to monitor, observe and/or provide limited operational capability to support safe and stable operational of the *distribution system*.
- (g) Require the installation of *network devices* to satisfy *network tariff* requirements.
- (h) Demonstrate design and/or commissioning information and certification from a Registered Professional Engineer of Queensland (*RPEQ*).

- (i) Require inspection and defect rectification prior to connection.

## 4.1.3 Connection offers

- (a) A connection offer from a *DNISP* for new connections or connection alterations can be either basic, standard or negotiated. The type of connection offer is determined based on criteria such as the connection type, the size and complexity of the connection and whether *DNISP* works are required to support the connection.
- (b) The majority of connection offers are for *small Customer* connections that are entitled to a basic connection offer. Basic connection offers, or model standing offers (MSOs), apply where supply or capacity is available, there is minimal network augmentation required and certain capacity and technical requirements are satisfied. All other connection offers by the *DNISP* are negotiated<sup>6</sup>.
- (c) There are a large range of connection types available for various connection activities, connection sizes, network types and functional requirements for the connection. The most common connection types can be seen below:
  - (i) single residential *premises*;
  - (ii) small commercial property;
  - (iii) temporary supply;
  - (iv) *micro-embedded generating units*;
  - (v) non-registered<sup>7</sup> *embedded generating units*;
  - (vi) *unmetered supply*;
  - (vii) large commercial *premises*;
  - (viii) real estate developments.
- (d) A connection offer may require additions or augmentation to the *distribution network*. *Proponents* may be required to allow time for these works to be completed prior to connection and may be subject to charges as per clause 4.1.4.
- (e) All *Customers* with an *EG* system must have a *connection contract* for the *EG* system in place with *the DNISP* before the *EG* system can be connected to the *DNISP's* supply network. This includes systems that are configured as *minimal-export* or *non-export* back to the *distribution system*.
- (f) The *Customer* or their agent shall nominate the metering scheme on the application form for network connection of an *EG* system and the *electrical contractor* shall nominate the metering scheme on their *EWR* sent to the *DNISP*.

## 4.1.4 Fees and charges

- (a) Information regarding fees and charges applicable to *Proponents* undertaking connection activities is available at the links shown in Table 8 in clause 4.1.2.

---

<sup>6</sup> The *DNISPs* do not currently provide standard connection offers. This information is based on the respective *DNISP connection policy* documents which have been approved by the AER in accordance with the *NEL* and the *NER* and may be subject to change.

<sup>7</sup> *Non-registered embedded generator* require approval to connect to the *DNISP* but do not require registration with Australian Energy Market Operator (*AEMO*).

- (b) A *Proponent* may be subject to charges for *distribution network* additions or augmentation to facilitate a new or modified connection.
- (c) Fees may be impacted by:
  - (i) the *tariff class* and *network tariff/s* which apply to the connection;
  - (ii) classification of the connection under the *DNSP connection policy* as a small or major *Customer*.

#### 4.1.5 Network tariffs

*DNSP* distribution services, including connection services, are subject to economic regulation by the Australian Energy Regulator (AER) under the National Electricity Law (*NEL*) and *NER*.

*Tariff classes* and *Customer* types will impact the primary and secondary *network tariffs* available to a *Customer*.

A high-level summary of the *network tariff* structure for the *DNSPs* is shown in Table 9. The information in Table 9 should be considered informative only, for detailed information on *tariff classes*, *Customer* types and *network tariffs* refer relevant *DNSP* Tariff Structure Statement and *DNSP* Network Tariff Guide.<sup>8</sup>

---

<sup>8</sup> Note *DNSP* Network Tariff Guide documents are approved annually by the AER in accordance with the *NEL* and *NER* and accordingly the information in Table 9 is subject to change.

**Table 9 Network tariff structure**

<b>Tariff class</b>	<b>Eligible Customers</b>	<b>Customer type</b>	<b>Primary tariff(s) options available</b>	<b>Secondary tariff(s) options available</b>
Standard Asset Customers (SAC)	(a) Customers connected at LV with installed capacity up to 1,000 kVA.	Residential	Yes	Yes
		Small business	Yes	Yes
		Large Customer	Yes	Yes
		Unmetered	Yes	No
		Solar FiT <sup>2, 3</sup>	Yes	No
Connection Asset Customers (CAC)	(a) Customers not assigned as ICC; (b) with installed capacity above 1,000 kVA; and (c) with a network coupling point at voltages from 11 kV to 66 kV.	NA	Yes	No
Individually Calculated Customers (ICC)	(a) Customers with a network coupling point at voltages from 33 kV to 132 kV; and (b) with installed capacity above 10 MVA. or (a) Customers with a network coupling point at voltages from 33 kV to 132 kV; and (b) with installed capacity below 10 MVA; where (c) certain criteria applies <sup>1</sup> .	NA	Yes	No

Note 1 – Information current at time of publishing and subject to change. See relevant *DNISP* Tariff Structure Statement and *DNISP* Pricing Proposal for latest and more detailed information on *network tariffs*.

Note 2 – The Solar Bonus Scheme FiT is a Grandfathered tariff closed to new *Customers*. For information on how to maintain eligibility to this tariff see: <https://www.qld.gov.au/housing/buying-owning-home/energy-water-home/solar/feed-in-tariffs/solar-bonus-scheme-44c>.

Note 3 – For information on an available Solar FiT, contact a Retailer.

## 4.2 New connections

Connections for initial supply shall follow the relevant *DNISP* process in clause 4.1.2.

An *Electrical Works Request (EWR)* shall be submitted for initial supply at a new connection to the *distribution system*.

## 4.3 Alterations of existing connections

### 4.3.1 Application and *EWR* requirements

Connection alteration activities may require a new connection application or connection alteration to be submitted. A new connection application shall be submitted for any *EG system* change or addition, including for *energy storage systems (ESS)* and photovoltaic (PV) panels.

An Electrical Work Request (*EWR*) shall be submitted for connection alterations which require the completion of *DNSP* works as follows:

- (a) Be submitted with adequate time allowed for completion of *DNSP* works before supply is required.
- (b) The *DNSP* shall be advised as early as possible when a connection alteration involves the alteration of an existing *HV* installation which may impact on the *connection assets* or *metering installation*.
- (c) The *DNSP* shall be advised when a connection alteration involves an electrical service may be over or in the vicinity of a swimming pool or hazardous area as defined in AS/NZS 3000.
- (d) Connection alterations which may require submission of an *EWR* include, but are not limited to:
  - (i) installation of additional phase/s;
  - (ii) removal of phase/s;
  - (iii) relocation of the *DNSP* service point with the *distribution system*;
  - (iv) a load increase that requires an increase in the capacity of the service or changes to the *distribution system*;
  - (v) the installation of a service following repair works (for example: repair works after storm damage);
  - (vi) work that requires a change to or additional *network device* (for example, load control equipment);
  - (vii) change to existing metering when the *DNSP* is the *Metering Provider*;
  - (viii) *IES EG system* additions, upgrades or replacement (Ergon Energy Network only).

### 4.3.2 Alteration classifications

- (a) An alteration is a modification to part(s) of an *electrical installation*.
- (b) A *Proponent* shall ensure compliance with the requirements of this *manual* when undertaking alterations works to an *electrical installation* at their *premises*.
- (c) An alteration may be either:
  - (i) a major alteration as per clause 4.3.2.1; or
  - (ii) a minor alteration as per clause 4.3.2.2.

#### 4.3.2.1 Major alterations

- (a) Where an alteration works is classified as a major alteration, all requirements of the *QECM* shall be met unless otherwise specified.
- (b) Major alteration works are shown in Appendix J.
- (c) A *Proponent* shall arrange for the relocation of a *DNSP service point*, *connection assets*, *OH service line*, *point of attachment* or *metering installation* before undertaking any works at a building or at a *premises* where the location may be classified as unsuitable during or after

completion of the works. These activities fall into the category of major alterations, including in the case of *premises* with multiple *DNSP service points* or *connection points*.

## 4.3.2.2 Minor alterations

- (a) Where an alteration works is classified as a minor alteration, *connection assets* may be left in existing locations if they are not in unsuitable locations as per clauses 9.8.1.2.
- (b) Minor alteration works and associated considerations are shown in Appendix J.

## 4.3.3 Undertaking repairs

- (a) A repair is the minimum work to restore the *electrical installation* to safe and sound working condition at the time of installation after deterioration or damage has occurred. If any modification or replacement occurs to the *electrical installation* as part of the works, this clause does not apply, refer to clause 4.3.2.
- (b) Where deterioration or damage has occurred to either a *point of attachment* or *metering installation* and they are in an unsuitable location the *DNSP* shall not reconnect a repaired connection. A *Proponent* shall refer to clause 4.3.2 to determine appropriate alteration requirements for reconnection.
- (c) In instances where the *metering installation* is not located in an unsuitable location, repairs may be carried out by using methods that were acceptable when that part of the *electrical installation* was originally installed, provided those methods satisfy the fundamental safety principles of Part 1 of AS/NZS 3000.
- (d) Where the metering terminal cover has been damaged or alterations to the metering cable entry point allows contact with live parts, the *Electrical Contractor* shall leave the installation in a safe state (e.g. fill/cover holes with a suitable material) and submit an *EWR* that advises a new metering terminal cover is required. Alterations to metering terminal covers are not permitted.
- (e) Any repairs on electrical infrastructure including the *point of attachment*, property poles and *meter board* shall be undertaken or supervised by an appropriately qualified person. For example, *Electrical Contractor* or *engineer*.

## 4.4 Technical studies

### 4.4.1 General

Where a *premises* includes or proposes to include both load and *EG system* connections, applications for new connections or alterations may require technical studies for both load and *EG system* connections.

### 4.4.2 Load connections

- (a) *Technical studies* shall be undertaken by the *DNSP* as part of negotiated connection application or connection applications with non-standard components and in accordance with jurisdictional requirements.
- (b) *Technical studies* for load connection applications may include, but not be limited to, studies into the following requirements:
  - (i) voltage regulation;
  - (ii) power flow;
  - (iii) fault level;
  - (iv) protection grading;

- (v) motor start.

### 4.4.3 *EG system connections*

Technical studies for *EG system* connection applications shall meet the requirements shown in the relevant *DNSP EG* connection standard (see Table 47).

## 4.5 *Distribution system works*

### 4.5.1 *General*

#### 4.5.1.1 *Relocation of distribution system assets*

Where a *Proponent* requests the relocation or removal of *distribution system* assets as part of a new or modified connection the following shall apply:

- (a) Requests for relocation of *distribution system* assets require a asset relocation enquiry and relevant approvals as per clause 4.8.
- (b) The *Proponent* is responsible for all fees and charges, as per clause 4.1.4, for relocation of *distribution system* assets. Fees and charges apply and may include additional charges for including but not limited to the cost to relocate third party assets located on the *distribution system* assets and the cost to reinstate roads or footpaths.

#### 4.5.2 *OH distribution system works*

##### 4.5.2.1 *Cross-road service poles*

The *DNSP* shall not install cross-road service poles unless the following conditions are met:

- (a) a service pole is required to maintain statutory clearances across the roadway; and
- (b) no property pole would be required if the *DNSP's* mains poles were erected on the same side of the road as the property.

##### 4.5.2.2 *Mid-span service*

Where a *Proponent* requests the installation, relocation or removal of a mid-span (flying fox) service as part of a new or modified connection the following shall apply:

- (a) Requests for a mid-span service require a negotiated connection application.
- (b) It is at the *DNSP's* discretion whether to approve a mid-span service.
- (c) A mid-span service connection will not proceed unless:
  - (i) *DNSP* approval under clause 4.8 is provided prior to the *DNSP* connection works being scheduled; and
  - (ii) the *Proponent* has paid the additional fees, as per clause 4.1.4, required for a mid-span service.

##### 4.5.2.3 *Rectification of aerial trespass*

A *Proponent* shall provide a suitable location for a *point of attachment* to prevent aerial trespass of a *service line* from the *distribution system* to the *point of attachment*.

Where a *Proponent* requests the relocation of an existing *service line* due to aerial trespass the following shall apply:

- (a) Requests for relocation of a *service line* due to aerial trespass requires an EWR and where a *DNSP* asset relocation is required refer to clause 4.5.1.1 for requirements.

- (b) Relocation of the *service line* is subject to an investigation by the *DNISP* and may not be approved if the investigation does not identify an aerial trespass.
- (c) The *Proponent* may be responsible for part or all fees and charges, as per clause 4.1.4, for relocation of *distribution system service line*.

Where a *DNISP* identifies an aerial trespass during connection works the *Proponent* may be required to make alterations to the proposed connection and may be responsible for part or all fees and charges, as per clause 4.1.4, for relocation of *OH service line* and/or *distribution system* assets to rectify the aerial trespass.

## 4.5.3 UG distribution system works

### 4.5.3.1 Substations on *Proponent's premises*

A *DNISP* substation(s) may be located on a *Proponent's premises*.

Where a *Proponent's point of attachment* to the *UG distribution system* is at a distribution transformer, the following shall apply:

- (a) The *Proponent* will provide and maintain at their expense, suitable space and tenure on their *premises* to accommodate a *DNISP* substation(s) and associated *connection assets*.
- (b) A *Proponent* may be required to provide a dedicated building for the *DNISP* to satisfy the requirements of (a).
- (c) The *Proponent* may be responsible for part or all fees and charges, as per clause 4.1.4, for installation the *DNISP* substation(s).

## 4.6 Connection, examination and testing

### 4.6.1 General

- (a) A *Proponent's electrical installation* shall not be connected to a *distribution system* unless a *DNISP* has conducted examination and testing and provided approval as specified in clause 4.6.2 and 4.6.3.
- (b) The *Proponent* remains responsible for the standard and compliance of the work, regardless of whether a connection officer from the *DNISP* examines, or tests, the whole or part of the *electrical installation*.
- (c) Any examination, test, connection or reconnection does not imply, suggest, indicate or endorse that the work performed complies with any specification.

### 4.6.2 Initial connection to the *distribution system*

- (a) As required under the *energy laws*, a *DNISP* connection officer shall:
  - (i) conduct examination of a *Proponent's consumer mains* and *main switchboard* to confirm there are no serious defects; and
  - (ii) conduct testing of a *Proponent's consumer mains* and *main switchboard* to confirm they are electrically safe,prior to the initial connection of an *electrical installation* to the *distribution system*.
- (b) All serious defects shall be rectified prior to connection of an *electrical installation* to the *distribution system*.

## 4.6.3 Reconnection to the *distribution system*

- (a) As required under the *energy laws*, a *DNSP* connection officer shall conduct a visual examination of a *Proponent's electrical installation* to confirm there are no serious defects prior to the reconnection of an *electrical installation* to the *distribution system*.
- (b) All serious defects shall be rectified prior to connection of an *electrical installation* to the *distribution system*.
- (c) A visual examination of a *Proponent's electrical installation* by the *DNSP* prior to the reconnection of an *electrical installation* to the *distribution system* may not be required for specified circumstances in the Electricity Safety Regulation 2013 (Qld) Section 220, subsections (2)(ii), 2(iii) and (3).

## 4.6.4 Breaking *metering installation* or *network device seals*

- (a) An *Electrical Contractor* is required to notify the *DNSP* or the *Metering Provider* before breaking or as soon as practicable after the event the seals on the following:
  - (i) Metering terminal cover;
  - (ii) Network device;
  - (iii) Metering Isolation Link;
  - (iv) Metering Neutral Link;
  - (v) Metering active link seals;
- (b) An *EWR* must be submitted to the *DNSP* immediately after the metering alterations are completed.

## 4.7 Authorised activities

### 4.7.1 General

- (a) A person that has satisfied the requirements for becoming an *authorised person* (electrical or non-electrical) shall undertake authorised activities as per clauses 4.7.2 and 4.7.3.
- (b) A person that has satisfied the requirements for becoming an *authorised person* (electrical or non-electrical) in (a) shall not undertake the non-authorised activities in clause 4.7.4.

### 4.7.2 Authorised person

- (a) A person approved by the *DNSP* as an *authorised person (electrical)* is permitted to work closer to the electric lines than an *untrained person* due their knowledge and competencies.
- (b) A person approved by the *DNSP* as an *authorised person (non-electrical)* does not hold a Queensland electrical work licence however, has enough technical knowledge and experience to do non-electrical work that involves being near electric lines and has been approved by us to work near electric lines.
- (c) To become an *authorised person* (electrical or non-electrical) an employer or self-employed person shall:
  - (i) Ensure the person(s) have an appropriate level of technical knowledge and skill.
  - (ii) Apply to the *DNSP* to request approval as an *authorised person* and nominate electrical or non-electrical. The application process and forms are available from the links in Table 10.

#### Table 10 Authorised person application process

<b><i>DNSP</i></b>	<b><i>Authorised persons application processes</i></b>
Energex	<a href="https://www.energex.com.au/contractors-And-service-providers/contractor-information/authorised-persons">https://www.energex.com.au/contractors-And-service-providers/contractor-information/authorised-persons</a>
Ergon Energy Network	<a href="https://www.ergon.com.au/network/contractors-and-industry/electrical-contractors/authorised-persons">https://www.ergon.com.au/network/contractors-and-industry/electrical-contractors/authorised-persons</a>

(iii) Satisfy the *DNSP* that their applicants have the required competencies. Approval is provided in writing and valid for 5 years, subject to (d).

(d) *Authorised person* approval is only valid for a person while they remain with the employer for which the *authorised person* application was approved.

### 4.7.3 Authorised activities

(a) An *authorised person (electrical)* shall obtain permission from the *DNSP* to work on or near *distribution system* assets prior to undertaking works.

(b) Authorised activities for an *authorised person (electrical)* include the following:

- (i) Work on or near the *point of attachment*.
- (ii) Remove and replace *LV* services fuses when required to isolate a *service line* to eliminate the exclusion zone around the *LV service line*, or to work on the *Customer's consumer mains* or switchboard.
- (iii) Isolate a *Customer's LV service line* at a *UG* pillar or service pole by removing a fuse wedge(s) from a *service line*, in accordance with electricity industry practices.
- (iv) Work at the *LV* end of a ground mounted distribution transformer.

### 4.7.4 Non-authorised activities

(a) An *authorised person (electrical)* shall not undertake non-authorised activities in relation to *distribution system* assets.

(b) Non-authorised activities include, but are not limited to, the following:

- (i) Replace a blown *LV* fuse after loss of supply to a *Customer's* connection.
- (ii) Replace an *LV* service fuse that has been removed by the *DNSP*.
- (iii) Alter, remove or relocate the *DNSP's OH LV service line* or *LV* pillar connections.
- (iv) Climb or work aloft on a *DNSP* pole or electricity assets.
- (v) *LV* isolation within locked *DNSP* assets.

## 4.8 Activities requiring approval

### 4.8.1 General

(a) A *Proponent* shall require approval for activities or designs requiring *professional engineering services* or for non-standard solutions as specified, but not limited to the connection activities shown in Table 11. This approval is required in addition to any other required approvals for the proposed connection activities and is specific to the *professional engineering services* or non-standard solutions relating to the activity in Table 11 only.

**Table 11 Activities requiring approval**

Clause	Activity requiring approval <sup>1</sup>
4.5.1.1	Relocation of <i>distribution system</i>
4.5.2.2	Mid-span service
4.6.2	Initial connection to <i>distribution system</i>
4.6.3	Reconnection to <i>distribution system</i>
4.7.2	Approval to become <i>Authorised Person</i>
4.8.2	Connection impacting a protected item
5.2.5	Provision of additional <i>DNISP service point</i>
5.4.2.1	Additional <i>connection points at a premises</i>
5.4.2.1	Multiple metering locations
5.6.2	Automated fail-safe interlocking of transformers
5.7	Supply beyond a property boundary
6.3	Minimum additional <i>OH service line</i> length
6.7.3(h)	Height of <i>point of attachment</i>
6.7.5	Raiser bracket
6.7.6.1	Property pole
6.8.1	<i>Consumer mains</i> on the <i>DNISP</i> pole
7.3	<i>UG DNISP service point</i> location in area with inadequate access
7.7.1	<i>UG DNISP service point</i> from <i>OH</i> service area
7.7.3	Connect to existing <i>UG</i> pit
8.14.5	AC motors
9.10.6	Platform requirements
9.8.5.1	Unmetered submains
9.11.2	<i>LV</i> CT metering drawings
9.11.3	<i>HV</i> metering drawings
10.7.3	Approval of non-typical direct connect metering arrangements for <i>EG system</i>
11.3.2	Use of <i>HV</i> metering voltage instrument transformers to supply <i>Proponent's</i> metering
11.3.2	Use of <i>HV</i> metering instrument transformers for power quality monitoring equipment

Note 1 – See relevant clauses and Appendix B for more detail on requirements related to approval.

- (b) A *Proponent* should make every effort to design an *electrical installation* which does not require any review or approval for a non-standard variation(s) to this *manual*, including adequate consideration of *electrical installation* requirements in the design and construction of buildings, design and selection of *electrical equipment*, in the master planning of *premises* and in the subdivision of land.

- (c) A *Proponent* requesting an activity requiring approval shall provide the *DNSP* with information required to support review and assessment of the approval application, including but not limited to the information identified in Appendix B.
- (d) A *Proponent* shall seek and obtain approval prior to undertaking any associated design or installation activity.
- (e) An activity requiring an application for approval may be subject to fees and charges from the *DNSP* to the *Proponent*. Fees and charges may apply regardless of the outcome of the application for approval.
- (f) A *DNSP* is not obligated to provide an approval for any activity shown in Table 11 or any other non-standard variation to this *manual*, except where required by law. The *DNSP* is not obligated to provide detailed information or engineering advice regarding any activities which are not approved .
- (g) Where an activity requires approval, adequate time shall be allowed by the *Proponent* for the *DNSP* to undertake any activities required to review, assess and determine an approval outcome. The likely time to provide approval will be advised to the *Proponent* during an application and may be impacted by, but not limited to, the following:
  - (i) statutory requirements;
  - (ii) the provision of required information from the *Proponent* to the *DNSP*;
  - (iii) time required to negotiate an agreed option;
  - (iv) the complexity of the proposed activity;
  - (v) the receipt of payment of fees or charges from the *Proponent* to the *DNSP*;
  - (vi) a requirement for *DNSP* works to be undertaken.
- (h) A request for approval for non-standard solutions may be declined where time or information supplied is not adequate to provide a review and meet connection activity timeframes.

## 4.8.2 Protected items

### 4.8.2.1 Categories and criteria

For the application of this *manual*, items shall be considered protected where they meet the criteria in Table 12.

**Table 12 Protected item categories and criteria**

Category	Criteria
A building or structure	Listed on a statutory heritage list
Vegetation, flora or fauna	Covered by statutory protection
Sensitive areas	Classed as a sensitive area by a statutory measure
Any cultural heritage artifact or site	Appropriate evidence supplied

### 4.8.2.2 Requirements

Where a *Proponent* is proposing a new or modified connection which may impact a protected item meeting the requirements of clause 4.8.2.1, the following requirements shall apply:

- (a) Provision of approval under clause 4.8 to support a connection which may impact protected items at the discretion of the *DNSP*; and

- (b) the following is required to be submitted by the *Proponent* with the connection application:
  - (i) certified documentation demonstrating the protected status with appropriate detail identifying the areas of the *premises* impacted by the protection orders for the protected item(s); and
  - (ii) any works plans required under legislation; and
- (c) a connection may require special arrangements for *DNSP* works. Any additional measures to support connection may be subject to fees and charges at the *Proponent's* expense.
- (d) The *DNSP* may consider, at its discretion, variations to the requirements in this *manual* for a connection which may impact a protected item.

### 4.8.3 Unmetered supply

Where a *Proponent* is proposing a new or modified connection of an *unmetered supply* the following requirements shall apply:

- (a) Requests for new or modified *unmetered supply* require a connection application.
- (b) A *Proponent* may not have an *unmetered supply* and a metered supply at the same *DNSP service point*.
- (c) The *electrical installation* consists of a small steady uniform load such as telephone cabinets, bus shelters and traffic signals.
- (d) An *unmetered supply* connection may be eligible for a model standing offer (MSO) where:
  - (i) for the supply location it is impractical to read or maintain a *metering installation* or the metering equipment would be susceptible to damage; and
  - (ii) the proposed connection is for a of *pre-approved unmetered supply device*; and
  - (iii) the proposed installation meets the terms of the model standing offer, see Appendix C.
- (e) Other than *unmetered supplies* meeting the requirements of (d), provision of an *unmetered supply* is a negotiated connection subject to *DNSP* approval and requires the *DNSP* to be satisfied that:
  - (i) for the supply location it is impractical to read or maintain a *metering installation* or the metering equipment would be susceptible to damage; and
  - (ii) approval must be gained from any relevant authority for equipment installed in the road reserve.<sup>9</sup>

### 4.9 Activities requiring *professional engineering services*

- (a) A *Proponent* shall ensure activities undertaken to design, commission, connect and operate an *electrical installation* and associated equipment on the *distribution system* are completed in compliance with the Professional *Engineers Act 2002* (Qld).
- (b) All parties providing services within Queensland shall meet the obligations of the Professional *Engineers Act 2002*.

---

<sup>9</sup> Refer to the Electricity Regulation 2006 (Qld).

- (c) All *professional engineering service* shall be completed or directly supervised by a Registered Professional *Engineer* of Queensland (*RPEQ*)<sup>10</sup>.
- (d) A person providing *RPEQ* certifications for a design or other activity for an *electrical installation* should be competent, registered in the appropriated discipline or engineering and suitably experienced to perform the task and engage other expertise as required.
- (e) Where *RPEQ* certification is required, the designer of an *electrical installation* or component of an *electrical installation*, should ensure that the design has been certified before installation or construction commences.
- (f) Where a *professional engineering service* is provided, an *Engineer* shall be responsible for the compliant and safe design and commissioning of the *electrical installation*, *electrical equipment* and any structure or plant for the *electrical installation*. This includes ensuring the *electrical equipment* or installation is designed to be electrically safe and that the design of structures or plant for the *electrical installation* are without risk to health and safety.
- (g) Where an *RPEQ* is also performing electrical work, licensing requirements in the Electrical Safety Act 2002 (Qld) shall also apply.
- (h) A *DNSP* may request the provision of a design or another activity from a Proponent demonstrate *RPEQ* certification where a *professional engineering service* has or will be undertaken.
- (i) The provision of a design or other activity certified by an *engineer* may not guarantee acceptance or approval from the *DNSP*.
- (j) A *DNSP* may request variations to a design or other activity undertaken by or for the *Proponent* which requires certification by an *engineer*.
- (k) Design and commissioning activities involved in the connection of *electrical installations* to the *distribution system* which may require demonstration of engineering certification to the *DNSP* include, but are not limited to, the activities in Table 13.

**Table 13 Engineering disciplines for design and commissioning activities**

Design and commissioning activities	Engineering discipline
Structures for electricity assets not covered by a <i>prescriptive standard</i> . (E.g., poles, riser brackets)	Structural
Design compliance reports	Electrical
Commissioning compliance reports	
Complex <i>electrical installations</i>	
Supply beyond a property line	
Centralised protection	
Earthing designs for electrical installations in <i>premises</i> supplied by multiple transformers	
Generating systems covered by STNW1174, STNW3511 and STNW1175	

<sup>10</sup> The Board of Professional Engineers of Queensland has a directory of Registered Professional Engineers of Queensland available here <https://bpeq.qld.gov.au/>.

Design and commissioning activities	Engineering discipline
Generating systems to multiple <i>electrical installations</i> using automated switching (including <i>off-grid generating units</i> )	
Switchboards where switchgear assemblies compliant with AS/NZS 61439	

## 4.10 Failure to comply

### 4.10.1 General

- (a) *Electrical installations* shall be designed, installed, maintained and operated in compliance with this *manual* and all other applicable rules.
- (b) Under no circumstances shall a *Proponent* take any action or proceed on an assumption that a variation will be granted by the *DNSP* for a non-compliance with this *manual*.

### 4.10.2 Notification of failure to comply

A *DNSP* or *Meter Provider* may issue a *Proponent* a notification of failure to comply with this *manual* or other applicable obligations, including but not limited to, when connecting or attempting to connect to the *distribution system*.

### 4.10.3 Rectification of non-compliances

A *Proponent* undertaking electrical work on an *electrical installation*, unless otherwise specified in this *manual*, shall rectify all non-compliances with this *manual* and any other applicable rules in compliance with clause 4.3.

Where a *Proponent* has received a previous variation to an obligation under this *manual* (or a previous version) and the *Proponent* is undertaking a major alteration any non-compliances associated with the *electrical installation* works shall be rectified.

Where a *Proponent* is issued a notification of failure to comply, by a *DNSP* or a *Metering Provider*, all defects or non-compliances shall be rectified by the *Proponent*.

In a case where an *electrical installation* fails to comply or satisfy the requirements of this *manual* or other applicable rules and until such time as the non-compliance(s) has been rectified:

- (i) the connection of electricity supply may be delayed or withheld; and
- (ii) *electrical installations* with supply may need to be disconnected.

## 5 General connection and supply requirements

### 5.1 Provision of supply

#### 5.1.1 General

- (a) The *Proponent* shall apply to the *DNSP* for new or altered supplies as per Section 4 of this *manual*.
- (b) The *DNSP* shall determine availability of supply as per clause 5.1.2.
- (c) The provision of supply will be dependent on the characteristics of the *distribution system* in the vicinity of the proposed connection including *distribution system*:
  - (i) voltage;
  - (ii) capacity;
  - (iii) phases available;
  - (iv) construction;
  - (v) location of assets; and
  - (vi) any non-standard network characteristics
- (d) The provision of supply may be subject to fees, a technical study and network augmentation.

#### 5.1.2 Availability of supply

- (a) The *DNSP* shall determine the availability of supply when a *Proponent* applies for a new or altered connection.
- (b) Where there is availability of supply, a connection to the *distribution system* may be able to be facilitated in a more timely and economic manner.
- (c) Availability of supply refers to:
  - (i) whether there is a line available, at the required phases and voltage and with sufficient rated capacity to support the proposed connection; and
  - (ii) connection activities will have minimal or no requirement for network augmentation.
- (d) Where there is no availability of supply, a connection to the *distribution network* may require network augmentation, network extension, redesign of a proposed connection or alternate supply options.

### 5.2 DNSP service point

#### 5.2.1 General

To facilitate provision of supply, the *DNSP* shall provide the *Proponent* with either an *OH DNSP service point* or an *UG DNSP service point* to connect supply from the *distribution system* to the *premises*. The following requirements apply to provision of a *DNSP service point*:

- (a) An initial *DNSP service point* shall be provided by and connected by the *DNSP*.
- (b) The *DNSP* shall install only one *DNSP service point* to a *premises*. The *DNSP* may install an additional *DNSP service point* where the conditions in clause 5.2.5.2 are demonstrated by the *Proponent*.
- (c) A *DNSP service point* shall only be provided to a *premises* where:
  - (i) a freehold lot directly abut a road reserve at ground level; or
  - (ii) a freehold lot does not directly abut road reserve, provide a registered services and access *easement* between the *premises* lot and the road reserve; or
  - (iii) the provision is to an *unmetered supply* on road reserve and it is installed in accordance with clause 4.8.3 (f).

- (d) Characteristics impacting the *DNISP service point* including the location of the *DNISP service point*, route and location of *connection assets*, termination point, number of phases, type, size and length (if relevant) of *connection assets* shall be determined by the *DNISP* in accordance with this *manual*.
- (e) The *DNISP* shall provide either an *OH* or *UG DNISP service point* based on the provision of supply requirements in clause 5.1.
- (f) Additional information on how to *DNISP* service points are allocated to embedded networks and *community title premises* specified in clause 5.5.3.
- (g) In the provision of a *DNISP service point*, a *point of attachment* and *connection point* to the *distribution system* will be established as per Section 6 and Section 7 for *OH* and *UG* connections respectively.
- (h) The *DNISP service point* provided shall be designed by the *DNISP* to accommodate the *Customer's* determined maximum demand, as per clause 8.14.1, and as agreed in the *Proponent's* connection agreement.

## 5.2.2 Charges for *DNISP service point*

- (a) A *DNISP* shall provide an initial *DNISP service point* to a *premises* at its expense unless stated otherwise in clause 5.2.2 (b).
- (b) The *Proponent* shall be responsible for all costs incurred by the *DNISP* associated with the following, unless specified otherwise in the *DNISP connection policy*:
  - (i) for the installation and removal of a temporary *DNISP service point* and any associated *service line*; and
  - (ii) for the supply and installation of additional *OH service line* length which exceeds the maximum length of a *service line* in Table 21 in clause 6.3; and
  - (iii) for the provision of an additional *DNISP service point(s)* and any associated *connection assets* in compliance with clause 5.2.5;
  - (iv) where the *Proponent* requests and the *DNISP* approves the installation of a *DNISP service point* and *connection assets*, other than a feasible technical solution offered by the *DNISP* to meet the *Proponent's* request e.g. additional phases, larger capacity *service line* or pillar;
  - (v) where the *Proponent* requests and the *DNISP* approves the request to alter, extend or relocate the point of origin of a *DNISP service point*, associated *connection assets* or *service line*.
- (c) A *DNISP* shall maintain the *OH service line*, where relevant, up to the *DNISP service point* at its expense.
- (d) The cost to install and maintain *consumer mains* after the *DNISP service point* are the responsibility of the *Proponent*.

## 5.2.3 Provision of access to the *DNISP service point*

The *Proponent* shall ensure sufficient clear unobstructed access to, and around, *DNISP connection assets*, the *DNISP service point*, *point of attachment* and *connection point* to allow the *DNISP* to safely maintain the *DNISP service point*.

## 5.2.4 Provisions of *consumer mains* and means to terminate

The *Customer* shall:

- (a) Provide and maintain a *consumer mains* at their expense.
- (b) Provide suitable terminations as per this *manual* on the *consumer mains* for connection by the *DNISP* to the *point of attachment* at the *DNISP service point*.

## 5.2.5 Provision of an additional *DN*SP service point

### 5.2.5.1 General

- (a) The provision of an additional *DN*SP service point to a *premises* under clause 5.2.5 requires approval and is at the discretion of the *DN*SP as per clause 4.8; and
- (b) the provision of an additional *DN*SP service point shall meet one of the following clauses as relevant:
  - (i) clause 5.2.5.2 for an additional *LV* *DN*SP service point; or
  - (ii) clause 5.2.5.3 for an additional *HV* *DN*SP service point; or
- (c) other than *premises* that meet (b), an additional *DN*SP service point or *OH* service line shall not be provided to a building that crosses multiple lot boundaries; and
- (d) the requirements for identification of multiple *electrical installations* in clause 5.6.3 shall be met; and
- (e) the provision of *DN*SP service points to a *premises* shall be a single voltage. For example, combinations of *HV* and *LV* voltages are not offered on the same *premises*;
- (f) the load and *EG* system connections shall be considered as an aggregation at the *premises* for the application of the *DN*SP connection policy, tariffs, standards, fees and charges and other requirements; and
- (g) an additional *DN*SP service point shall not be provided to supply a building or buildings not physically separated as per AS/NZS 3000 *MEN* requirements, including all associated structural metalwork, conductive building materials and underground levels; and
- (h) the *DN*SP will determine if it is more practical to supply the load on the *premises* through more than one *DN*SP service point; and
- (i) where an additional *DN*SP service point is provided, the *Proponent* may be subject to all costs for provision of the additional *DN*SP service point as per clause 5.2.2 and the *DN*SP Connection Policy; and
- (j) *distribution systems* are subject to reconfiguration including for operational and maintenance purposes. Where a *Proponent* has more than one *DN*SP service point approved to supply a *premises*, the approval may be conditional on operational restrictions agreed between the *DN*SP and the *Proponent* for particular contingency operational scenarios on the *distribution systems*.

### 5.2.5.2 Provision of an additional *LV* *DN*SP service point

A *Proponent* may be provided with an additional *LV* *DN*SP service point where clause 5.2.5.1 and the following requirements are met:

- (a) the maximum demand or the security of supply requirements for the *premises* support the connection of an additional *LV* *DN*SP service point; and
- (b) only *LV* *DN*SP service points are supplying the *premises*; and
- (c) interconnection of any *electrical installations* shall meet the requirements of clause 5.6.2 and Table 14; and
- (d) the requirements in Table 14 are met and maintained over time for the relevant options.

**Table 14 Requirements for options for additional *LV DNSP service point***

Option	Max no. of <i>DNSP service points</i>	Total number of transformers supplying <i>premises</i>	Distance between additional <i>DNSP service points</i>	<i>Electrical installation requirements</i>
LVXSA	no more than 1 every 200 m along Customer's property alignment	<ul style="list-style-type: none"> <li>Number of transformers, based on site specific determination by <i>DNSP</i></li> <li>Transformer supply may not be dedicated to <i>premises</i>.</li> </ul>	≥ 200 m between <i>DNSP service points</i> , measured along the <i>Customer's</i> property alignment	<ul style="list-style-type: none"> <li>Load supplied is ≥ 100 m from any building supplied by the <i>DNSP service point</i></li> <li>Load supplied is ≥ 50 m from any <i>electrical installation</i> supplied by the <i>DNSP service point</i></li> <li>No interconnection permitted between <i>electrical installations</i> as per clause 5.6.2.</li> </ul>
LV2SB	2	2 dedicated transformers with equal rated capacity	Adjacent in common <i>easement</i>	<ul style="list-style-type: none"> <li>The <i>DNSP service points</i> shall supply separate buses of the same main switchboard, installed in a switch room.</li> <li>The buses shall meet the requirements for multiple transformers in clause 5.6.2.</li> </ul>
LV3S	3	3 dedicated transformers with equal rated capacity	Adjacent in common <i>easement</i>	<ul style="list-style-type: none"> <li>The <i>DNSP service points</i> shall supply separate buses of the same main switchboard, installed in a switch room.</li> <li>The buses shall meet the requirements for multiple transformers in clause 5.6.2.</li> </ul>

### 5.2.5.3 Provision of additional *HV DNSP service point*

A *Proponent* may be provided with additional *HV DNSP service point* where clause 5.2.5.1 and the following requirements are met:

- the maximum demand or the security of supply requirements for the *premises* support the connection of an additional *HV DNSP service point*; and
- only *HV DNSP service points* are supplying the *premises*; and
- interconnection of any *electrical installations* shall meet the requirements of clause 5.6.2.

### 5.2.6 Converting from multiple *LV DNSP service points* to a *HV DNSP service point*

- Where an *LV* connected *premises* has up to three *DNSP service points* and requires additional capacity, they may apply to convert from multiple *LV DNSP service points* to a *HV DNSP service point* provided the following requirements are met:
  - as per clause 5.2.5.1 the *premises* shall only be supplied from the *distribution system* with a single voltage; and
  - a *HV metering installation* shall be arranged by the *Proponent* with a *Retailer*.

- (b) The *DNSP* may provide the *Proponent* with an option to procure the existing *DNSP connection assets* to enable the conversion from *LV* to *HV*.

## 5.3 Determining number of phases

A *Proponent* shall determine the number of required phases for all new and altered connections. The permitted number of phases for a *DNSP service point* connected to the *distribution system* is shown in Table 15.

**Table 15 Determining phase requirements for a *DNSP service point* connected to the *distribution system***

Number of <i>Customer electrical installations at premises</i>	Maximum demand (A)	Number of phases permitted		
		1-phase	2-phase	3-phase
1	≤ 100	Yes	No <sup>2</sup>	Yes
	> 100	No	No <sup>2</sup>	Yes
2	≤ 100	Yes	Yes <sup>4</sup>	Yes
	> 100	No	Yes <sup>4</sup>	Yes
3 +	Any	No	No	Yes

Note 1 – For installations with multiple *Customers*, individual *Customers* may individually be supplied by 1-phase where phase balancing requirements in clause 8.4 are maintained for the *DNSP service point*.

Note 2 – A *split-phase* SWER option may be approved in accordance with clause 6.8.2 (c).

Note 3 – Individual *electrical equipment* shall not be connected across multiple *Customers' electrical installations*.

Note 4 – 2-phase connections are restricted to duplex *premises* with two *Customer electrical installations*.

Note 5 – Unless otherwise approved by the *DNSP* on a *Proponent's* connection application a maximum of 80 A fuse will be installed. Refer to Section 9 and 10 for direct connected or current transformer metering requirements.

To determine the required number of phases for a *DNSP service point* a *Proponent* shall:

- Determine the number of *Customer* installations for the *DNSP service point*. Refer to clause 5.2 for *DNSP service point* requirements.
- Determine the connection offer type required and associated demand limits as per clause 5.5.1.
- Determine future electrical load requirements for the *Customer* (e.g., hot water, air-conditioning, cooking, pool or spa pump, *ESS*, *Electric Vehicle Supply Equipment (EVSE)*).
- Calculate the maximum demand in accordance with AS/NZS 3000.
- Determine and account for any impacts to requirements of any individual switched equipment in accordance with clause 8.14.2.2.
- Determine future generation capacity and *export* requirements (solar *PV*, *ESS*, *V2G* and *EVSE*).

- (g) Ensure capability to manage phase-balancing requirements from clause 8.4 for multi-phase premises.

## 5.4 Connection Point

### 5.4.1 General

- (a) All metered and *unmetered supply electrical installations* connected to the *distribution system* shall have:
  - (i) a single *connection point*; and
  - (ii) a corresponding *National Metering Identifier (NMI)*.
- (b) Metered installations shall also have a meter installed in compliance with Section 9 and 10 or 9 and 11 as relevant.
- (c) An *unmetered supply electrical installation* shall have:
  - (i) only one *connection point*; and
  - (ii) only one *NMI*; and
  - (iii) only one type of unmetered device.
- (d) An *unmetered supply electrical installations* shall be installed in compliance with clause 4.8.3.
- (e) An individual *Customer* shall only have one *connection point* per *premises* unless approved under clause 5.4.2.
- (f) A *community title premises* shall meet the requirements for clause 5.5.3.2 (b) for *connection points*.

### 5.4.2 Additional connection points at a premises

#### 5.4.2.1 General

- (a) The approval of any additional *connection points* and associated *NMIs* for an *electrical installation* shall be in accordance with the requirements clause 5.4.1, 5.4.2.2 and 5.4.2.3 this *manual*.
- (b) A *Proponent* shall not have more than one *connection point* per *premises* other than for a *Proponent* with multiple *DNISP service points* that have been approved in compliance with Option LVXSA in Table 14 in clause 5.2.5.2.
- (c) No *connection point* at a *premises* shall be located further within an *electrical installation* than any other *connection point* at a *DNISP service point*.
- (d) Where there are more than 12 *connection points* and corresponding *NMIs* provided to a *premises* the *DNISP* may provide approval for multiple metering locations in accordance with clauses 9.8.3 and 9.8.4.

#### 5.4.2.2 Additional connection points at a premises for single DNISP service point

Where a *premises* is supplied by a single *DNISP service point*, all *connection points* shall be at the same physical location in accordance with clause 9.8.

#### 5.4.2.3 Additional connection points at a premises for multiple DNISP service points

For a *premises* supplied by multiple *DNISP service points* in compliance with clause 5.2.5.2 the following requirements apply:

- (a) Where additional *DNISP service points* are approved by the *DNISP* and provided in accordance with Option LVXSA in clause 5.2.5.2, there will be a *connection point* located in accordance with clause 6.7.1 or clause 7.6 for each *DNISP service point*. Any additional *connection points* provided for *DNISP service point* shall be in the same physical location as the *connection point* associated with the relevant corresponding *DNISP service point*.

- (b) Where two or three *DNSP service points* are approved by the *DNSP* and provided in accordance with either Option LV2SB or Option LV3S respectively, in clause 5.2.5.2, the following applies:
- (i) For a single *Customer*, no additional *connection point* shall be provided for the *premises*. There shall be a single *connection point* associated with a single point across all *DNSP service points* in accordance with clause 6.7.1 or clause 7.6; or
  - (ii) For multiple *Customers*, with multiple *connection points* and *NMIs*, the *connection point* shall be at the same location as the *DNSP service point* in accordance with clause 6.7.1 or clause 7.6.1. In this arrangement each *electrical installation* is connected to one of the *DNSP service points*. Any additional *connection points* provided for a *DNSP service point* shall be in the same physical location as the *connection point* associated with the relevant corresponding *DNSP service point*.
- (c) For *HV* connections with multiple *DNSP service points*, only one *connection point* and *NMI* shall be provided per *DNSP service point*. The physical location of the *connection point* shall be in accordance with clause 6.7.1 or clause 7.6.1 for each *DNSP service point*.

## 5.5 Connection types

### 5.5.1 General

Limits for demand and capacity are based on the connection offer type as described in Section 3 of the relevant *DNSP connection policy*<sup>11</sup>. An indication of the type of connection provided by the *DNSP* at the connection point is shown in Table 16 and Table 17. The maximum demand limits in Table 16 and the maximum capacity limits in Table 17 shall not be exceeded.

**Table 16 Demand connection offer types per connection type**

Connection offer type	Connection type	Maximum demand limit (A)
Basic	<i>Urban</i>	≤ 100 A
	<i>Rural</i>	≤ 80 A
	<i>SWER</i>	≤ 40 A
Negotiated	All other types and maximum demand limits	As negotiated

Note 1 – All *isolated network* connection types are negotiated.

Note 2 – All demand requirements for an *ESS* connected to an *IES* shall not exceed the maximum demand requirements for the relevant demand connection offer.

Note 3 – A basic connection by the *DNSP* includes the installation of an 80 A fuse. Refer to Section 9 and 10 for direct connected or current transformer metering requirements.

Note 4 – For the purpose of this clause the definitions of *urban* and *rural* are as per the *DNSP connection policy*.

<sup>11</sup> Further information on connection offer types can be found in Section 3 of the relevant *DNSP connection policy*.

Table 17 Capacity connection offer types per connection type

Connection offer type	Connection type	Maximum capacity and export limits
Basic	Micro-EG unit	Refer to EG Standards
Negotiated	All others	As negotiated

Note 1 – Micro-EG refers to EG systems up to 200 kVA see Appendix C for Basic EG connection agreements.

Note 2 – All isolated network connection of types are negotiated.

Note 3 – All demand requirements for an ESS connected to an IES shall not exceed the maximum demand requirements for the relevant demand connection offer.

## 5.5.2 Embedded networks

### 5.5.2.1 Connecting an embedded network

The following requirements apply where a *Proponent* seeks to establish or augment an embedded network connection to the *distribution system*:

- The owner of the embedded network *premises* shall operate and maintain private network infrastructure, including child *metering installations* not directly connected to the *distribution system* in accordance with the requirements of AEMO.
- The sale of electricity within the embedded network shall be in accordance with the requirements of the Australian Energy Regulator (AER).
- Connection requirements to the *DNISP* shall apply with respect to the connection of the *distribution system* to the privately owned embedded network.
- An embedded network shall have a single connection agreement between the *DNISP* and the embedded network owner or operator.
- An embedded network shall have a single *DNISP service point, connection point, and NMI* associated with connection to the *distribution system* unless otherwise approved in accordance with this *manual*.
- All *EG systems* shall be approved by the *DNISP* as per clause 8.15.1 prior to connection within the *embedded network*.

### 5.5.2.2 Connecting within an embedded network

The following requirements apply where a *Proponent* is seeking to connect or augment the connection to or within a privately owned embedded network:

- Demand and capacity limits are allocated at the *connection point*.
- Demand connections and alterations to the *connection assets* or modifications which impact on the connection agreement for an embedded network shall be approved by the *DNISP* prior to undertaking works.
- All *EG system* connections and alterations shall be approved by the *DNISP* prior to connection within the embedded network.
- A *Proponent* shall be responsible for gaining approval from an embedded network owner or operator prior to submitting a connection application with the *DNISP*.
- In the case where embedded network *Customers* apply for direct connection to the *DNISP distribution network*, all *Customers* within the embedded network must agree to and be direct connected to the *distribution system*. Any private network and *metering installations* which

will become part of the *distribution system* shall be compliant with all *DNISP* requirements at the time of change of connection.

## 5.5.3 Subdivisions

### 5.5.3.1 General

For a *premises* that has been subdivided, other than *community title* which is considered under clause 5.5.3.2, the *DNISP* may approve the provision of more than one *DNISP service point* that meets the following:

- (a) separate individual *premises* where each portion of land has a separate freehold title;
- (b) the land associated with each of the *premises* directly abuts a public road reserve; and
- (c) there is no interconnection of the *electrical installations* across lot boundaries; and
- (d) the buildings are physically separated by an area as per AS/NZS 3000 *MEN* requirements, including all associated structures and underground levels.

Additional *DNISP service points* may be provided to an individual lot in a subdivision where it meets the requirements for additional *DNISP service points* as per clause 5.2.5.

### 5.5.3.2 Community title

- (a) For a *community title premises*, the *DNISP service point* shall be provided based on *community title* scheme type as per Table 18, drawing QCD09-04 and the following requirements:
  - (i) there is no interconnection of the *electrical installations* across lot boundaries for lots with a *connection point* to the *distribution system*; and
  - (ii) multiple *DNISP service points* shall not be provided where buildings on a premises are not physically separated by an area as per AS/NZS 3000 *MEN* requirements, inclusive of all associated structures and underground levels.

**Table 18 *DNISP service point* provision based on *community title* scheme at a *premises***

<b>Community title scheme type<sup>1</sup></b>	<b><i>DNISP service point</i><sup>5</sup></b>
(a) Dual occupancy <i>domestic premises</i> <sup>2</sup>	One <i>DNISP service point</i> on or from road reserve per <i>premises</i> to <i>common property</i> .
(b) Multi-unit <i>domestic premises</i> in <i>building format plan</i> <sup>3</sup>	
(c) <i>Customer</i> reticulated	One <i>DNISP service point</i> on or from road reserve per <i>premises</i> to <i>common property</i> .
(d) <i>DNISP</i> reticulated to single occupancy <i>domestic premises</i> – via road reserve (not driveway) <sup>4</sup>	One <i>DNISP service point</i> on or from road reserve per individual lot.

<b>Community title scheme type<sup>1</sup></b>	<b>DNISP service point<sup>5</sup></b>
(e) Exclusive use area for each <i>premises</i> – via road reserve (not driveway)	One <i>DNISP service point</i> on or from road reserve per individual lot.
(f) Highrise <i>premises</i> ≥ 5 floors <sup>5</sup>	One <i>DNISP service point</i> on or from road reserve per <i>premises</i> to <i>common property</i> . <i>DNISP service point</i> may be located at a distribution transformer.

Note 1 – A *community title premises* DNISP service point shall only select a single option of (a), (b), (c) or (d) from Table 18 for a development.

Note 2 – For example, duplexes..

Note 3 – see definitions, a *building format plan* is where a lot boundary is the floor, wall, or ceiling of the building.

Note 4 – Single *DNISP service point*, supplying a service to only one lot directly from road reserve and *DNISP* assets are within the boundaries of the lot and is not within a boundary structure (floor, wall or ceiling serving as lot boundary) for the lot.

Note 5 – Additional *DNISP service points* may be provided where a *community title* meets the requirements for additional *DNISP service points* as per clause 5.2.5.

- (b) *Community title premises connection points* shall be provided in compliance with clause 5.4 and clause 9.8.4 and:
  - (i) For embedded networks have one *connection point*; or

## 5.6 Have one *connection point* per lot. Note only one *connection point* shall be provided for a *common property* lot e.g. a community meter. Multiple *electrical installations*

### 5.6.1 General

*Premises* with multiple *electrical installations* include any of the following:

- (a) *premises* supplied by more than one *DNISP service points*;
- (b) *premises* with more than one *connection point*;
- (c) *community title premises*, excluding those connected as an *embedded network* with a single *connection point*.

### 5.6.2 Multiple distribution transformers

- (a) For a *premises* provided an additional *LV DNISP service point* under clause 5.2.5.2 and connected under option LVXSA, the following requirements shall apply:
  - (i) No interconnection is permitted for *electrical installations* supplied from two *DNISP service points*<sup>12</sup>.
  - (ii) No form of bus-tie switching arrangement is permitted between any of the distribution transformers for the *electrical installations* supplied by the distribution transformers.

---

<sup>12</sup> As *distribution networks* are subject to reconfiguration for operational purposes, where a *premises* has been supplied by more than one *DNISP service point*, clause 5.6.2 (a) shall apply regardless of whether two transformers supply a *premises* in normal configuration.

- (b) For a *premises* provided an additional *LV DNSP service point* or points under clause 5.2.5.2 and connected under option LV2SB or LV3S with multiple distribution transformers, the following requirements shall apply:
- (i) For option LV2SB, the *DNSP* distribution transformers supply separate buses of the *Proponent's* main switchboard installed in a switch room.
  - (ii) For option LV3S the *DNSP* distribution transformers supply separate buses of the same *Proponent's* main switchboard that is installed in a switch room.
  - (iii) A *Proponent* is permitted to use a bus-tie interlocking arrangement for either LV2SB or LV3S options where the requirements in Table 19 are met.
  - (iv) For multiple switchboards other than those covered by (b) (iii), the switchboard arrangement shall comply with the requirements of Figure 2.

**Table 19 Bus-tie interlocking arrangement requirements**

Connection arrangement	Fail-safe interlocking <sup>1</sup> requirement
Multiple distribution transformers and/or <i>DNSP service points</i>	<ul style="list-style-type: none"> <li>(i) Comply with Figure 1</li> <li>(ii) No distribution transformers or <i>DNSP service points</i> are connected in parallel.</li> <li>(iii) The interlocking mechanism (bus-tie switch) should be a manual (key based) fail-safe system that cannot operate under load. Where a manual interlocking system is used it shall be fitted with a warning label to indicate the operating requirements.</li> <li>(iv) Automated controlled fail-safe interlocking systems may be allowed upon approval of a functional design and operational specification certified by an RPEQ and submitted with the relevant drawings<sup>4</sup> for approval. Additional fees may apply. Where an automatic interlocking system is used it shall be fitted with a warning label to indicate that the system may operate automatically and how it may be safely isolated.</li> </ul>
<i>Off-grid generating unit</i>	During the transfer from one source to another the interlock operation cannot allow the <i>generating unit</i> and the <i>distribution system</i> to both supply the load at the same time.
Bumpless transfer generating system	Interlock compliance and operation as per requirements in <i>EG Standards</i> . No distribution transformers or <i>DNSP service points</i> will be connected in <i>parallel</i> at any point during the bumpless transfer.

Note 1 – Interlocking shall be installed and identified in compliance with AS/NZS 3000.

Note 2 – An interlocking mechanism (bus-tie) between *DNSP service points* shall only be located in a main switchboard. The interlocking mechanism shall not be located between the *DNSP service point* and the *metering installation* or the *DNSP service point* and the main switch.

Note 3 – The meter isolator shall not be used for automatic interlocking or automatic transfer functions. This includes legacy installations where the meter isolator and the main switch are the same switch.

Note 4 – LV CT metering drawings as per clause 9.11.2 or drawings as per *EG system* standards in clause 8.15.1.

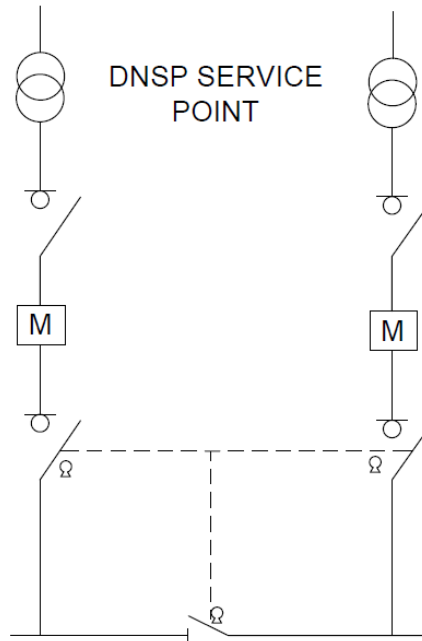

**Figure 1** *General arrangement of multiple DNSP service point with bus-tie interlocking*

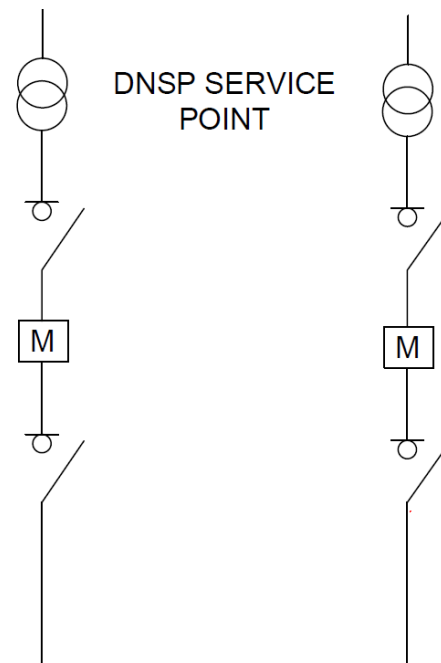

**Figure 2** *General arrangement of multiple DNSP service point with no bus-tie*

## 5.6.3 Identification in *premises with multiple electrical installations*

### 5.6.3.1 General

For *premises with multiple electrical installations* the following requirements apply:

- (a) Each individually metered section of a multiple *electrical installation* shall be clearly identifiable.
- (b) The number shall be permanently marked on the *meter board*, main switchboard, distribution board (if applicable), meter, isolator and front door of the individual unit, shop, building or similar.
- (c) A site plan of the overall layout of the site shall also be permanently displayed on the inside door of the *meter board*.
- (d) Supply arrangement diagrams showing *meter boards*, switchboards, wiring, *EG systems*, all meters and *unmetered supplies* shall be installed and maintained at each *meter board*.
- (e) The *DNSP* shall require compliance to clause 5.6.3.1 (a) to (d) prior to initiating connection of the *electrical installations*, inclusive of reconnection activities.

## 5.6.3.2 Identification in *premises* with two *DNSP service points* in option LVXSA

For *premises* where the *DNSP* approves additional *DNSP service points* configured as per option LVXSA in clause 5.2.5.2, the following requirements apply:

- (a) The *Proponent* shall identify zones A, B, C etc. as required for the multiple *electrical installations*. Zone boundaries should be as simple as possible, using obvious boundaries such as roads, fences or waterways and shall not cross or intermingle.
- (b) The *Proponent* shall produce a diagram to identify zones on the *premises* for the two separate *electrical installations* with the following minimum information:
  - (i) the lot number;
  - (ii) the *DNSP service point* and *NMIs* shown;
  - (iii) both geographical and electrical demonstration of the extent of the zones;
  - (iv) minimum separation distances between *electrical installations* required in Table 14 shall be displayed on the diagram to indicate areas where *electrical installations* cannot be extended; and
  - (v) all switchboards as well as any equipment remote of a building (such as lighting, gates etc.) shall be labelled on the diagram with a unique identifier to the *premises*, with the zone letter as part of the naming.
- (c) A copy of the diagram with zone's identified shall be:
  - (i) printed and kept in all main switchboards and should be located in all distribution boards;
  - (ii) all switchboards shall be clearly labelled onsite with the unique identifier shown in the diagram; and
  - (iii) any equipment remote of a building within 80 m of the boundary between the zones, shall be clearly labelled onsite with the unique identifier shown in the diagram.
- (d) Zone diagrams shall be installed and maintained at each *meter board*.

## 5.7 Supply beyond a property boundary

A *Proponent* may install and operate an *LV electrical installation* on a place beyond the person's property in accordance with Section 24 of the Electricity Regulation 2006 (Qld). Key requirements include:

- (a) the *Proponent* shall have written approval from *DNSP* and any other entity, with an interest in the location of the *electrical installation* prior to connection; and
- (b) the *Proponent* shall provide the *DNSP* with copies of approvals by other entities where the *Proponent* is proposing to install an electric line on road reserve, prior to undertaking works;
- (c) in all other cases, the *DNSP* may request copies of any written approvals for supply beyond a property boundary provided to the *Proponent* from other entities;

- (d) the *DNSP* reserves the right to withdraw an approval for supply beyond a property boundary where changes are made to the design or operation of the *electrical installation*;
- (e) the installation and operation of the electric line is not likely to cause a fire or a person to suffer an electric shock; and
- (f) the *electrical installation* shall meet the requirements of this *manual*.

## 5.8 Active device management

- (a) An *electrical installation* may have *electrical equipment* which is controlled via *active device management*.
- (b) *Active device management* types are classified as per Table 20 below based on the power system outcome of the *active device management* and whether the management is related to a network control tariff.

**Table 20 Active device management classification**

<b>Active device management classification</b>	<b>Power system outcome</b>	<b>Network tariff related</b>
Type 1	<i>NEM System Support</i>	No
Type 2	<i>Distribution system support</i>	Yes
Type 3	<i>Distribution system support</i>	No

- (c) The requirements for *electrical equipment* that may be controlled via *active device management* and the criteria are specified in clause 8.10.

## 5.9 Non-standard connection and supply arrangements

The following arrangements are non-standard and shall be subject to limited access or assessed for technical limitations identified on a case-by-case basis.

### 5.9.1 Isolated networks

- (a) *Isolated networks* are small remote electricity *distribution systems* operated by Ergon Energy Network that are not connected to the national electricity grid and are supplied via a dedicated power station.
- (b) The communities supplied by *isolated networks* are shown in Figure 8 in Appendix G.
- (c) The only connection offer type available in *Isolated Networks* is negotiated as per clause 5.5.1.
- (d) The conditions of supply and metering requirements detailed in this *manual* apply to all *Customers' electrical installations* in *isolated networks* and are to be read in conjunction with Ergon Energy Network document *PW000202R114 - Guidelines for Electrical Installations at Isolated Systems*.<sup>13</sup>

---

<sup>13</sup> Contact *Customer* service from Appendix N for a copy of *PW000202R114 - Guidelines for Electrical Installations at Isolated Systems*.

## 6 Overhead connection and supply requirements

### 6.1 General

This Section applies to overhead (*OH*) connection and supply requirements for *LV* and *HV* connections to the *distribution system*. The general connection and supply requirements in Section 5 shall apply in addition to the *OH* connections and supply requirements in this Section.

### 6.2 DNSP service point

- (a) For the provision of an *OH DNSP service point*, the *DNSP* shall determine the relevant option or options available for connection at a *premises*. The standard *OH DNSP service point* characteristics and options available for the *DNSP* to consider for provision of a *service line* are shown in Table 21:

**Table 21 *OH DNSP service point* options for connection to *premises***

<i>OH DNSP service point</i> characteristic	Voltage	Options/Requirements
Location of <i>DNSP service point</i>	<i>LV</i>	<i>DNSP</i> pole fuse mid-span service <sup>1</sup>
	<i>HV</i>	Lugs connecting <i>consumer mains</i> to <i>ABS</i>
Route of <i>service line</i>	<i>LV</i> and <i>HV</i>	direct route in compliance with clause 5.2.1(d) and clause 6.4. Aerial trespass not permitted <sup>2</sup> .
<i>OH service line</i>	<i>LV</i>	As per clause 6.3 and clause 6.5
	<i>HV</i>	Site specific determination
<i>Point of attachment</i>	<i>LV</i> and <i>HV</i>	As per clause 6.6 and clause 6.7
Access requirements		
Connection arrangement		

Note 1 – Approval for connection of a mid-span service is at the *DNSP*'s discretion, for requirements applying to mid-span services see clause 4.5.2.2.

Note 2 – Refer to Table 23.

- (b) Prior to planning for the installation of an *OH DNSP service point* from the *distribution system* a *Proponent* shall consult with the *DNSP* to understand likely options available or required for a proposed connection. A *Proponent* should be aware however, that connection options can only be confirmed as part of the connection offer for an application.

### 6.3 *OH service line*

- (a) The *DNSP* shall provide and install an *OH service line* to a *premises* for the provision of the initial *DNSP service point*.
- (b) The maximum length of a *service line* is shown in Table 22.

Table 22 Maximum length of an *OH service line*

Construction	Maximum length of <i>service line</i> <sup>1,2</sup>
<i>OH</i>	20 m

Note 1 – an *OH service line* shall be measured from the *Customer's* property alignment or, if the line does not cross the property alignment, the point of origin of the *service line*.

Note 2 – a minimal additional *OH service line* length may be approved by the *DNSP* as a negotiated connection under clause 4.8. Where approved, charges apply to the installation of the additional *OH service line* length as per clause 5.2.2.

- (c) Only the *DNSP* shall install, connect, alter, remove, or relocate an *OH LV service line*. See clause 4.7 for more detail on authorised activities and non-authorised activities.

### 6.3.1 Provision of access to the *service line*

The *Customer* shall ensure sufficient clear unobstructed access to the *service line*, around, and below the *point of attachment* and *connection point* to allow the *DNSP* to safely maintain the *service line*.

### 6.3.2 Provisions of means to terminate *service line*

A *Proponent* shall provide the *DNSP* the facilities and means for entrance, support, protection, and termination of an *OH service line*.

## 6.4 Unsuitable routes or *point of attachment* locations for *OH service lines*

- (a) The *DNSP* shall not install or connect an *OH service line* at the *DNSP service point* where the route and *point of attachment* location of an *OH service line* is unsuitable as identified in Table 23.

**Table 23 Unsuitable routes or *point of attachment* locations for *OH service lines***

Category	Unsuitable routes or <i>point of attachment</i> locations for <i>OH service lines</i>
Inadequate clearance from ground, buildings, or structures	Any location where the minimum clearance requirements from the <i>OH service line</i> to ground, buildings, or structures in Drawings QCD06-01 and QCD06-02 are not able to be achieved or maintained.
Trees or other flora	The route for an <i>OH service line</i> where trees or other flora may contact the line.
Aerial trespass	A route that would result in the <i>OH service line</i> crossing an adjacent property or <i>premises</i> resulting in an aerial trespass.
Pools or spas	(i) Within or at any height above any pool or spa zone as defined in AS/NZS 3000; or (ii) any location which requires entering a fenced area around a pool or spa.
Hazardous areas	(i) Within any hazardous area defined in AS/NZS 3000; or (ii) within a gas emitting device (gas meter regulator) exclusion zone defined by AS/NZS 5601.1, AS/NZS 60079.10.1 and AS 4645.1; (iii) in particular, <i>Electrical Contractors</i> should be aware of the hazardous areas associated with exchange or in-situ fill LPG gas cylinders.
Joint use arrangement	Any additional <i>point of attachment</i> location on <i>premises</i> <sup>1</sup> or property pole which already has one <i>point of attachment</i> location.
Access to roof	A <i>point of attachment</i> location or position requiring a <i>DNSP's</i> personnel to climb onto a roof.

Note 1 – Additional *point of attachments* are allowed for a *premises* with *DNSP* approval for multiple *DNSP service points* compliant with Option LVXSA as per clause 5.2.5.2.

Note 2 – A *Proponent* shall notify the *DNSP* of any subsequent works planned for the *premises* which may result in a proposed *service line* route or *point of attachment* being unsuitable. Subsequent works may include but are not limited to installation of a pool, driveway, awning, or trafficable area; building alterations; and changes in landscaping.

- (a) A *Proponent* shall arrange for the relocation of a *OH service line* before undertaking any works at a *premises* where the *service line* route or *point of attachment* location may be classified as unsuitable during or after completion of the works.

## 6.5 *OH service line* cable

- (a) A *DNSP* shall select and install a standard *OH service line* cable for a *service line* as follows:

- (i) The standard *OH service line* cables which may be used by the *DNSP* for a *service line* are shown in Table 24 for each *DNSP*. Table 24 also shows the service rating and maximum fuse size for the respective *service line* cables; and

**Table 24 Standard *OH service line* cables used by each *DNSP***

<i>DNSP</i>	Cable type (ABC)	<i>Service line</i> rating (A)	Maximum fuse size (A)
Energex	2*6mm <sup>2</sup> Cu XLPE	50	30
	2*25mm <sup>2</sup> Al XLPE	105	80
	3*25mm <sup>2</sup> Al XLPE	100	80
	4*25mm <sup>2</sup> Al XLPE	100	80
	4*35mm <sup>2</sup> Al XLPE	120	100
	2*95mm <sup>2</sup> Al XLPE	230	200
	4*95mm <sup>2</sup> Al XLPE	215	200
	Parallel 4*95mm <sup>2</sup> Al XLPE <sup>2</sup>	430	315
Ergon Energy Network	2*25mm <sup>2</sup> Al XLPE	105	80
	4*25mm <sup>2</sup> Al XLPE	97	80
	2*50mm <sup>2</sup> Al XLPE	150	125
	4*50mm <sup>2</sup> Al XLPE	140	100
	2*95mm <sup>2</sup> Al XLPE	230	125
	4*95mm <sup>2</sup> Al XLPE	215	160
	Parallel 4*95mm <sup>2</sup> Al XLPE <sup>2</sup>	430	315

Note 1 – A 6mm<sup>2</sup> copper *service line* may be used for small *unmetered supplies*. For example, telephone cabinets.

Note 2 – Larger capacities are typically supplied by the *DNSP* with an *UG service line* however, paralleling of 4 core 95mm<sup>2</sup> *OH service lines* may be used by the *DNSP* for commercial or industrial connections but shall not be permitted for residential connections.

- (ii) the *DNSP's* overhead construction manual specifies the minimum requirements for *OH service line* cables including fuse sizes.
- (b) Where a *Proponent* applies for additional capacity the *OH service line* shall be replaced if the aggregate of the existing and additional proposed load exceeds the current carrying capacity of the existing *OH service line*.

## 6.6 Provision of *point of attachment* for *OH service line*

### 6.6.1 Provision of *point of attachment* for *OH service line*

The *Proponent* shall:

- (a) provide and maintain at their expense, suitable space, equipment, and structure(s) on their *premises* acceptable to the *DNSP* for the attachment and connection of a *service line* to *consumer mains*; and
- (b) provide and maintain the *consumer mains*.

## 6.6.2 Provision of space and facilities for future connection assets

In establishing an OH connection a *Proponent* may be required to provide and maintain at their expense, suitable space, structures(s) and facilities on their *premises* acceptable to the *DNSP* for future location of UG connection assets including a distribution substation in accordance with Section 59 Queensland Electricity Regulation 2006 (Qld) where the aggregate maximum demand for the *premises*:

- (i) exceeds 100 kVA; or
- (ii) is reasonably estimated to exceed 100 kVA in the future; and
- (iii) maximum demand is as determined by AS/NZS 3000.

## 6.7 OH point of attachment and DNSP service point

### 6.7.1 General

- (a) The *DNSP* shall determine the relevant *point of attachment* option for the *OH DNSP service point* and associated *connection point* from Table 25 for connection of a *premises*; and **Table 25 OH point of attachment and connection point options**

Voltage	Point of attachment	Connection point
LV	Building	Termination of first span of <i>OH service line</i> at <i>point of attachment</i>
	Structure	
	Raiser bracket	
	Property pole	
HV	Air Break Switch (ABS) <sup>1</sup>	Lugs connecting <i>consumer mains</i> to ABS

Note 1 – *DNSP* owned ABS located on *distribution system*

Note 2 – Where a *DNSP service point* supplies multiple individually metered *electrical installations*, via a single or multiple *meter boards*, in compliance with clause 9.8.3 or 9.8.4, the *connection point* for each *point of attachment* is the metering isolation device.

- (b) the *connection point* shall be at the *point of attachment* where the *DNSP service point* terminates at a *premises*.

### 6.7.2 Provision of means to terminate service LV OH service line at point of attachment

A *Proponent* shall provide the means for a *DNSP* to terminate the LV OH service line to meet the requirements of clause 6.7.4.

### 6.7.3 OH service line attachment and connection point requirements

The following requirements apply to *OH service line* attachments and *connection points*:

- (a) *OH service line* cables shall be compliant with the *DNSP* standards as shown in clause 6.5.
- (b) The method of attachment of an *OH service line* to a structure shall be such that mechanical load is transmitted to the frame of the structure.
- (c) *OH service line* attachments include eye bolts, raiser brackets and property poles and shall apply the *safe working loads (SWL)* as per Table 26.

**Table 26 Safe working loads (SWL) applying to the point of attachment for OH service lines**

Cable size	OH service line cable options for DNSPs		Safe working load (SWL)
	Energex	Ergon Energy Network	
25mm <sup>2</sup>	Yes	Yes	1.0 kN
35mm <sup>2</sup>	Yes	No	
50mm <sup>2</sup>	No	Yes	3.5 kN
95mm <sup>2</sup>	Yes	Yes	
parallel 95mm <sup>2</sup>	Yes	Yes	7.0 kN

Note 1 – SWLs shall be multiplied by 2.0 to convert to limit state principles.

Note 2 – As per Table 26, paralleling of 4 core 95mm<sup>2</sup> OH service lines may be used by the DNSP for commercial or industrial connections but shall not be permitted for residential connections.

- (d) Approved attachment details for 1 kN and 3.5 kN OH service line attachments are contained in Table 27.

**Table 27 Attachment options for OH service lines with Safe working loads (SWL) of 1.0 kN and 3.5 kN**

Safe working load (SWL)	Minimum attachment size	Attachment option
1.0 kN	M12	open eye screw
	M12	eye bolt <sup>2</sup>
3.5 kN	M16	closed eye bolt

Note 1 – J-hooks shall not be used on facias or poles

Note 2 – Refer to drawings QCD06-04 and QCD06-09 for open or closed eye bolt type.

- (e) A Proponent should use an approved prescriptive standard for design and commissioning of an OH service line attachment supported by a structure (e.g., raiser bracket, property pole). Where the approved prescriptive standard option is used, there shall not be no modifications, including even simple welding attachments. The approved prescriptive standard options include (i) or (ii) as follows:
- (i) the approved prescriptive standards for OH point of attachments in Table 28;

**Table 28 Approved OH point of attachment prescriptive standard drawings**

Attachment structure type	SWL	Cable size	Drawing no.	Drawing information
Facia	1.0 kN	25/35 mm <sup>2</sup>	QCD06-04	connection and bridging details
	3.5 kN	50/95 mm <sup>2</sup>	QCD06-05	connection and bridging details
	-	50/95 mm <sup>2</sup>	QCD06-06	mains box connection details
Raiser bracket	1.0 kN	25/35 mm <sup>2</sup>	QCD06-07	connection and bridging details
	3.5 kN	50/95 mm <sup>2</sup>	QCD06-08	connection and bridging details
Wood and Steel Property pole	5 kN (wood) / 1.0 kN (steel)	25/35 mm <sup>2</sup>	QCD06-09	connection and bridging details
	5 kN (wood) / 3.5 kN (steel)	50/95 mm <sup>2</sup>	QCD06-10	connection and bridging details
Steel Property pole	1.0 kN and 3.5 kN	25/35 mm <sup>2</sup> and 50/95 mm <sup>2</sup>	QCD06-11	General arrangement
	1.0 kN	25/35 mm <sup>2</sup>	QCD06-12	Fabrication details
	1.0 kN	25/35 mm <sup>2</sup>	QCD06-13	Foundation construction details
	3.5 kN	50/95 mm <sup>2</sup>	QCD06-14	Fabrication details
	3.5 kN	50/95 mm <sup>2</sup>	QCD06-15	Foundation construction details
Consumer mains on DNSP pole	-	-	QCD06-16	Consumer mains on DNSP pole
Steel Builders Temporary Service (BTS) pole	1.0 kN	25/35 mm <sup>2</sup>	QCD06-17	General arrangement
	1.0 kN	25/35 mm <sup>2</sup>	QCD06-18	Fabrication and construction details (page 1 of 2)
	1.0 kN	25/35 mm <sup>2</sup>	QCD06-19	Fabrication and construction details (page 2 of 2)

(ii) manufacturer supplied and endorsed *prescriptive standards* in the *DNSP Approved OH point of attachment* list available on the respective *DNSP* website.

- (f) Where an approved *prescriptive standard* is not used, the design and commissioning of an *OH service line* attachment supported by a structure (e.g., raiser bracket, property pole, BTS pole) is considered a *professional engineering service*. A *DNSP* may approve a *OH point of attachment* supported by a structure that is not an approved *prescriptive standard* where the *Proponent* meets the requirements of clause 4.8 and clause 4.9.

- (g) Where raiser brackets or eyebolts are used, the design and installation shall make provision for work to be carried out safely (refer to the applicable workplace health and safety legal requirements).
- (h) The maximum height of a *point of attachment*:
  - (i) to a building shall be 8 m; and
  - (ii) to a pole should 8 m, where a height exceeding 8 m is required to maintain statutory clearances shall obtain approval as outlined in clause 4.8.
- (i) The point of attachment is to be mounted within 600 mm from the top of the pole. This distance from the top of the pole may be increased to ensure the point of attachment is no higher than 8 m from the ground.
- (j) The *point of attachment* and the *connection point* shall be positioned on the building or structure where *DNSP* personnel have unobstructed ready and safe access from the same common ladder position. The *Proponent* shall ensure design of clear level and safe access to the *point of attachment* to allow the *DNSP* to maintain the service. A clear level area below the *point of attachment* that allows a ladder ratio of 4:1 vertical to horizontal is deemed suitable.
- (k) The *DNSP service point*, *point of attachment* and *connection assets*, including *service line*, shall not be located:
  - (i) in an unsuitable location as per clause 6.4; or
  - (ii) where *DNSP* personnel are required to do any of the following: climb on roofs; enter adjoining properties; or carry ladders through structures, and or buildings for access.

## 6.7.4 Termination of LV OH service line

The LV OH service line termination shall meet the following requirements:

- (a) For *service line* cables up to 95mm<sup>2</sup>, a *suitable mains connection box* that meets the following requirements:
  - (i) equipped with house service connectors for the connection of a *OH service line* by the *DNSP*; and
  - (ii) mounted to provide adequate support by brackets or similar and not be reliant on rigid conduit for support, see Appendix A; or
- (b) where either the *service line* or *consumer mains* are of a size not suitable for a *suitable mains connection box*, an enclosure that meets the following requirements:
  - (i) UV resistant insulated enclosure meeting the requirements of Table 29; and

**Table 29 Suitable sizes UV resistant insulated enclosures**

UV resistant insulated enclosure	
Service line cable type	PVC enclosure size
Single 35 or 50mm <sup>2</sup> LV ABC service	360mm X 270mm X 205mm <sup>1</sup>
Single & Parallel (Twin) 95mm <sup>2</sup> LV ABC service	540mm X 360mm X 220mm

Note 1 – Some manufacturers utilise a spacer to achieve 220mm depth

- (ii) equipped with crimp cable lugs complete with shroud, 12mm stainless steel bolts, nuts, washers, and spring washers for terminating the *consumer mains*; and

- (iii) mounted vertically with entry of *consumer mains* positioned low, through the bottom of the enclosure; and
  - (iv) where double insulated sheathed cables are used for the *consumer mains*, remove the sheathing in accordance with the manufacturer's instructions prior to termination into the Insulation Piercing Connector (IPC); and
  - (v) the requirements in Appendix A.
- (c) Clamps shall be provided for connection of *LV OH service line* to single *OH consumer mains*. When installing parallel OH consumers mains the requirement to provide clamps does not apply.
- (d) Where the *OH service line* is terminated onto aerial *OH consumer mains*, a *suitable mains connection box* or enclosure is not required.
- (e) Conductor identification in compliance with clause 8.2.

## 6.7.5 Raiser bracket

For raiser brackets the following requirements apply:

- (a) Where using a raiser bracket as a *point of attachment* the *Proponent* shall meet clause 6.7.1, clause 6.7.2 and clause 6.7.3.
- (b) A raiser bracket shall have a maximum height of 1.2 m.
- (c) The minimum *SWL* of a raiser bracket shall meet the requirements of Table 27 in clause 6.7.3.
- (d) A raiser bracket shall be fitted with a means of attachment suitable for high wind conditions e.g., a pigtail or closed loop fitting.
- (e) The raiser bracket *OH service attachment* drawings in Table 28.
- (f) A raiser bracket used to attach an *OH service line* shall be either:
  - (i) A commercially available raiser bracket which is endorsed by the *DNISP* and listed in the *DNISP Approved OH Service Attachment List* available on the respective *DNISP* website. Where a *Proponent* requires variation to the *prescriptive standards* that apply to the installation and commissioning of a *DNISP* listed raiser bracket, clause (ii) applies; or
  - (ii) Where an approved *prescriptive standard* for a raiser bracket is not used, the design and commissioning of raiser bracket is considered a *professional engineering service* and requires demonstration by the *Proponent* of engineering certification to the *DNISP* in accordance with clause 4.9.
- (g) The raiser bracket shall be fitted with a label that meets the requirements of clause 8.2.1 and displays the *SWL*.
- (h) A raiser bracket shall be fitted to a structure such that:
  - (i) Where hardwood timber is used as an anchorage for 1 kN raiser brackets and eye bolts, it is to be a minimum of 100mm x 75mm and securely fastened to or be part of the building structural frame.
  - (ii) A through rafter roof mounted raiser brackets is positioned a maximum of 0.5 m backwards from the edge of the roof or guttering.
- (i) A raiser bracket shall not be mounted on a fascia without suitable bracing to the structural frame.
- (j) A raiser bracket using a stay wire shall be positioned so that the stay wire is attached to the roof in line with the direction of the *OH service line* pull (+/- 20 degrees).
- (k) A raiser bracket or the connecting *OH service line* shall not be located:
  - (i) in an unsuitable location as per clause 6.4; or

- (ii) where *DNSP* personnel are required to do any of the following: climb on roofs; enter adjoining properties; or carry ladders through structures, and or buildings for access.

## 6.7.6 Property pole

### 6.7.6.1 General

For property poles the following requirements apply:

- (a) Where using a property pole as a *point of attachment* the *Proponent* shall meet clause 6.7.1, clause 6.7.2 and clause 6.7.3.
- (b) A property pole shall comply with AS/NZS 3000 Appendix D and the additional requirements in this clause.
- (c) The property pole shall meet the following requirements based on its type:
  - (i) a wood pole that meets the requirements of clause 6.7.6.2; or
  - (ii) a steel pole that meets the requirements of clause 6.7.6.3; or
  - (iii) another type of pole that meets the requirements of clause 6.7.6.4.
- (d) A property pole shall be located a maximum of 20 m:
  - (i) from the property boundary located on road reserve and meet the requirements of (e); or
  - (ii) from the origin of the *OH service line*, where the *OH service line* does not cross a property boundary located on road reserve.
- (e) The length of the *OH service line* supplying a property pole shall:
  - (i) be approved by the *DNSP* where it exceeds 20 m; and
  - (ii) not exceed 50 m from the point of origin of the *OH service line* to the *point of attachment* on the property pole, where the *OH service line* crosses a road reserve; and
  - (iii) fees apply, as per clause 4.1.4, where an *OH service line* exceeds 20 m in accordance with requirements clause 6.3.
- (f) A property pole or the connecting *OH service line* shall not be located:
  - (i) in an unsuitable location as per clause 6.4. Specifically, a property pole must have a minimum of 3.0 m clearance to the *DNSP* distribution system assets (excluding the connecting *OH service line*) and meet the clearance requirements to all other structures of drawing QCD06-02 including other *Customer* property poles; or
  - (ii) where *DNSP* personnel are required to do any of the following: climb on roofs; enter adjoining properties; or carry ladders through structures, and or buildings for access.
  - (iii) Access to property poles shall be maintained for the purposes of inspection, maintenance, repairs and emergency situations.
  - (iv) The base of the property pole and surrounding ground shall be clear of vegetation for the purposes of inspection, maintenance, repairs and emergency situations.
- (g) The *point of attachment* for a property pole shall meet the applicable connection and bridging requirements in either drawing QCD06-09 or QCD06-10.
- (h) A property pole shall be securely set in the ground to meet the requirements of AS/NZS 3000. A pole manufacturer may specify different foundation requirements based on the soil quality. The soil quality definition shall be used as per Table 30.

**Table 30 Soil quality**

Soil type	Description	Pressure gradient (kPa/m)
poor	Soft clay, poorly compacted sand and soils that tend to absorb large amounts of water	150 kPa/m
medium	Compact medium clay, well-bonded sandy loam, bonded sand, and gravel with reasonable surface water drainage	300 kPa/m
good	Well compacted rock soil, hard clay and well-bonded sand and gravel with good surface water drainage	450 kPa/m

- (i) Private equipment, other than the *consumer mains*, may be installed on a property pole, provided that the private equipment is located:
  - (i) at minimum of 1.2 m below the *point of attachment* and not above the *OH service line*; and
  - (ii) in a position that does not limit access to the *point of attachment*;
  - (iii) a *meter board* enclosure on a property pole shall meet the requirements of clause 9.9.2; and
  - (iv) any attachment to the property pole is approved and *RPEQ* certified in compliance with clause 4.8 and 4.9.

## 6.7.6.2 Wood property poles

- (a) A wood property pole shall be treated in compliance with the requirements in AS/NZS 3000 Appendix D:
  - (i) with a preservative treatment in accordance with AS 3818.11; and
  - (ii) the base of the property pole and surrounding ground is treated against insect and fungal attack by environmentally approved methods; and
  - (iii) the property pole is capped at the top to prevent water penetration.
  - (iv) The base of the property pole and surrounding ground shall be clear of concrete, tiles, pavers etc or any other prohibitive materials so that the pole may be inspected underground. A required clearance of 300mm must be maintained around the base of the pole.
- (b) A wood property pole shall have a minimum *SWL* of 5 kN. The *SWL* will be labelled with a pole disc meeting the requirements of clause 8.2.1.
- (c) A design or construction of a wood property pole that has been relocated or repaired requires approval under clause 6.7.3 (f).
- (d) For connection to Ergon Energy Network's *distribution system*, all wood property poles shall be a minimum of 5 m out of the ground.

## 6.7.6.3 Steel property poles

- (a) A steel property pole shall:
  - (i) be designed, constructed, and installed to prevent internal and external corrosion; and
  - (ii) have a rag bolt assembly that is clearly accessible.
- (b) A steel property pole shall meet the minimum *SWL* in clause 6.7.3 required for the *OH service line attachment*.
- (c) The steel property pole shall be designed and constructed to either:
  - (i) an approved *prescriptive standard* design available in this document in Table 28; or

- (ii) a design listed on the Approved *OH* service attachment list as per clause 6.7.3 (e) (ii);  
or
- (iii) a design approved by the *DNISP* under the requirements of clause 6.7.3 (f).

## 6.7.6.4 Other property poles

Another type of property pole may be permitted for use as a *OH* service attachment by the *DNISP* where it meets the following requirements:

- (a) The property pole is designed, constructed, and installed to prevent internal and external corrosion.
- (b) The property pole shall be designed and constructed to either:
  - (i) a design listed on the Approved *OH* service attachment list as per clause 6.7.3 (e)(ii); or
  - (ii) a design approved by the *DNISP* under the requirements of clause 6.7.3 (f).

## 6.8 Non-standard *OH* connection and supply arrangements

The following arrangements are non-standard and shall be subject to limited access or assessed for technical limitations identified on a case-by-case basis.

### 6.8.1 Consumer mains on *DNISP* pole

- (a) *Consumer mains* installed on a *DNISP* pole is considered a non-standard *OH point of attachment* and is subject to:
  - (i) approval as per the requirements of clause 4.8 at the discretion of the *DNISP*; and
  - (ii) criteria based on the type of installation as per (b) and (c); and
  - (iii) assessment of the suitability of the *DNISP* pole for *consumer mains* on a *DNISP* pole as per *QECM* drawing QCD06-16.
- (b) For *unmetered supply electrical installations* the following criteria shall be met to be considered for approval by the *DNISP* for connection of *consumer mains* on a *DNISP* pole:
  - (i) the installation is owned by a telecommunications company, public company, public body, or other company (approved by a public body); and
  - (ii) the installation is installed on public land; and
  - (iii) the maximum demand is not more than 100 A per phase; and
  - (iv) a connection agreement is to be established.
- (c) For metered installations the following criteria shall be met to be considered for approval by the *DNISP* for connection of *consumer mains* on a *DNISP* pole:
  - (i) the *distribution system* is within the boundary of the *Customer's premises*; and
  - (ii) the installation actual demand is above 400 A; or
  - (iii) the installation is owned by a public body or other company (approved by a public body);  
and
  - (iv) can demonstrate a community benefit in not installing a property pole (e.g., supply to park land); and
  - (v) the *meter board* location shall not be more than 20 m from the *DNISP service point*; and
  - (vi) the maximum demand is not more than 100 A per phase.
- (d) If approved, the *consumer mains* on a *DNISP* pole shall be constructed as per *QECM* drawing QCD06-16 and the *DNISP* Underground Construction Manual.

### 6.8.2 Single Wire Earth Return (*SWER*)

- (a) Single Wire Earth Return (*SWER*) networks are parts of the HV *distribution system* that use a single live conductor with the earth as the return current path.
- (b) *Premises* supplied from *SWER* are at *LV* either as single-phase or *split-phase*.

- (c) A *SWER* transformer supplies two phases at 230V line to neutral, with 180 degrees phase angle. A single *Customer* on a *SWER* networks may be approved for a 460 V *split-phase* where there is an available line.
- (d) The maximum demand limit for a basic *connection agreement* for a *Proponent* on a *SWER* network is in clause 5.5.1 Table 16 and basic capacity and export limits for *EG systems* are in Table 17.
- (e) Maximum demand limits for loads as well as capacity and export limits for *EG systems* on a *SWER* network, above the basic limits in (d), are negotiated as per clause 5.5.1. A consideration for negotiated offers is a maximum capacity of the *DNSP* assets at *DNSP service point* of on *SWER* networks is 50 kVA.
- (f) The connection of a motor for a *Proponent* on *SWER* network requires approval as per clause 8.14.5.1 and clause 4.8.
- (g) The earthing at a *SWER* transformer pole is for the HV *distribution system*, is hazardous and covers a large area.

## 6.9 Builders temporary supply

A *Proponent* may use a Builder's Temporary Supply (BTS) while undertaking construction activities at a *premises*. Use of a BTS shall meet the following requirements:

- (a) Meet the design and construction requirements for a reusable steel pole in drawings QCD06-17, QCD06-18 and QCD06-19.
- (b) Install a *suitable mains connection box* as per clause 6.7.4 for connection of an *OH service line*.
- (c) Have a metered supply and a *meter board* compliant with clause 9.9.
- (d) The *point of attachment* is to be mounted within 600 mm from the top of the pole. This distance from the top of the pole may be increased to ensure the *point of attachment* is no higher than 8 m from the ground.
- (e) The *connection point* is to be as per clause 6.7.1(b).

Where the building has an existing connection to the network, the use of a BTS requires the existing supply to be abolished. Refer to *Appendix J* for alteration classification associated with reconnection activities.

## 7 Underground connection and supply requirements

### 7.1 General

This Section applies to Underground (*UG*) connection and supply requirements for *LV* and *HV* connections to the *distribution system*. The general connection and supply requirements in Section 5 shall apply in addition to the *UG* connections and supply requirements in this Section.

### 7.2 *UG DNSP service point*

- (a) For the provision of an *UG DNSP service point* to the *distribution system* the *DNSP* shall determine the relevant option or options available for connection at a *premises*. The standard *UG* connection characteristics and options available for the *DNSP* to consider for provision of a *DNSP service point* are shown in Table 31:

**Table 31 *UG DNSP service point* options for connection to *premises***

<b><i>UG</i> connection characteristic</b>	<b>Voltage</b>	<b>Options/Requirements</b>
Location of <i>DNSP service point</i>	<i>LV</i>	Pillar fuse panel  <i>LV</i> terminals of distribution transformer
	<i>HV</i>	Load side bushings of the Ring Main Unit (RMU)
<i>DNSP connection assets, point of attachment and DNSP service point</i>	<i>LV</i> and <i>HV</i>	Located on road reserve or in <i>easement</i> . Compliance with <i>DNSP UG Construction Standards</i> as per clause 3.1.1.

- (b) Prior to planning for the installation of an *UG DNSP service point* from the *distribution system* a *Proponent* shall consult with the *DNSP* to understand likely options available or required for a proposed connection. A *Proponent* should be aware however, that connection options can only be confirmed as part of the connection offer for an application.
- (c) Only the *DNSP* shall install, connect, alter, remove, or relocate an *UG DNSP service point*. See clause 4.7 for more detail on authorised activities and non-authorised activities.

## 7.3 Unsuitable locations *connection assets* for *UG DNSP service point*

- (a) The *DNSP* shall not install or connect a *DNSP service point* where the route and *point of attachment* location of a *UG DNSP service point* is unsuitable as identified in Table 32.

**Table 32 Unsuitable routes or *point of attachment* locations for *UG DNSP service point***

Category	Unsuitable routes or <i>point of attachment</i> locations for <i>UG DNSP service point</i>
Areas exposed to water	A pillar with an <i>UG DNSP service point</i> shall not be installed within 1000 mm of: <ul style="list-style-type: none"> <li>• an area designed to permanently capture and store water; or</li> <li>• a floodway; or</li> <li>• other locations likely to sustain damage due to water inundation including areas; or</li> </ul> not be subject to tidal inundation, storm surge or flood events exceeding 10% Annual Exceedance Probability (AEP).
Areas with inadequate access	In areas with inadequate, unsafe, or insecure access for the <i>DNSP</i> for operational purposes.
Creating an obstruction	In an area where the <i>DNSP service point</i> is an obstruction or public nuisance.
Uneven or structurally inadequate areas	Areas not flat or structurally sound
Insecure areas	Areas not able to be secured from third party or environmental damage.
<i>Rural areas</i> <sup>1</sup>	<i>Rural areas</i> are considered unsuitable for the provision of <i>UG DNSP service point</i> due to risk of vehicle impact and fire damage.
Trafficable areas	Within 1000 mm of a kerb or edge of trafficable areas.

Note 1 – The *DNSP* may approve to locate an *UG DNSP service point* in a *rural* area subject to approval under clause 4.8.

- (b) A *Proponent* shall arrange for the relocation of a *UG DNSP service point* before undertaking any works at a *premises* where the location of the *DNSP service point*, *point of attachment* or *connection assets* may be classified as unsuitable during or after completion of the works.

## 7.4 Provision of space and facilities for *UG connection assets*

The *Proponent* shall where requested:

- (a) Provide and maintain at their expense, suitable space, equipment, structure(s), and facilities on their *premises* acceptable to the *DNSP* for the installation of *DNSP connection assets* for a *DNSP service point*.<sup>14</sup>

<sup>14</sup>For more information refer to Energex Commercial and Industrial Substation Manual and Energex Construction Manual or Ergon Energy Network Indoor Distribution Substation Design Standard and Ergon Energy Construction Manual.

- (b) Provide and maintain at their expense, suitable space, equipment, structures(s) and facilities on their *premises* acceptable to the *DNSP* for a distribution substation in accordance with Section 59 Queensland Electricity Regulation 2006 (Qld) where the aggregate maximum demand for the *premises*:
  - (i) exceeds 100 kVA; or
  - (ii) is reasonably estimated to exceed 100 kVA in the future; and
  - (iii) maximum demand is as determined by AS/NZS 3000.
- (c) Where required, obtain any *easements* or similar requirements as considered in clause 5.2.1(c) and clause 8.8.3 (d).

## 7.5 Provision of *consumer mains* for *UG* connection

The *Proponent* shall:

- (a) Provide and maintain a *consumer mains* at their expense.
- (b) Provide suitable terminations, fixtures, and equipment as per clause 7.6.3.1 of this *manual* on the *consumer mains* for connection by the *DNSP* to the *point of attachment*.

## 7.6 *UG* point of attachment and connection point requirements

### 7.6.1 General

The following requirements apply to the *UG* point of attachment and connection point:

- (a) The *DNSP* shall determine the relevant *point of attachment* option for the *UG* *DNSP* service point and associated *connection point* from Table 33 for connection of a *premises*; and

**Table 33 *UG* point of attachment and connection point options**

Voltage	Point of attachment	Connection point
LV	Pillar	LV fuses in the <i>point of attachment</i> .
	Pit	
	Distribution transformer	LV terminals of the distribution transformer; or
		Load terminals of <i>DNSP</i> owned LV switch installed at the distribution transformer; or
Load terminals of <i>DNSP</i> owned LV circuit protective device installed at the distribution transformer.		
HV <sup>1</sup>	Ring main unit (RMU)	Load side bushings of the RMU.
	Recloser	Load terminals of <i>DNSP</i> owned recloser; or
		Line terminals of Customer owned recloser.
	Circuit breaker	Load terminals of <i>DNSP</i> owned circuit breaker; or
Line terminals of Customer owned circuit breaker.		
HV > 66 kV	Isolator	Load terminals of <i>DNSP</i> owned isolator.

Note 1 – Refer to STNW3522 for connection arrangement options.

Note 2 – Where a *DNSP* service point supplies multiple individually metered *electrical installations*, via a single or multiple *meter boards*, in compliance with clause 9.8.3 or 9.8.4, the *connection point* for each *point of attachment* is the metering isolation device.

(b) the *connection point* shall be at the *point of attachment* where the *DNSP service point* terminates at a *premises*.

## 7.6.2 UG Pillar

(a) UG pillar types and maximum DNSP service point connection rating is shown in Table 34.

**Table 34 UG pillar types and ratings of DNSP service point connection**

UG pillar type	Maximum DNSP service point connection rating (A/phase)	Maximum consumer mains number per phase and size (mm <sup>2</sup> )
Cross road pillar	100	1 x 35
supply pillar	100	1 x 35
C & I pillar <sup>1</sup>	160	1 x 240
distribution cabinet	400	2 x 300

(b) Note 1 – Commercial and industrial pillarA typical LV UG service pillar connection is shown in Figure 3.

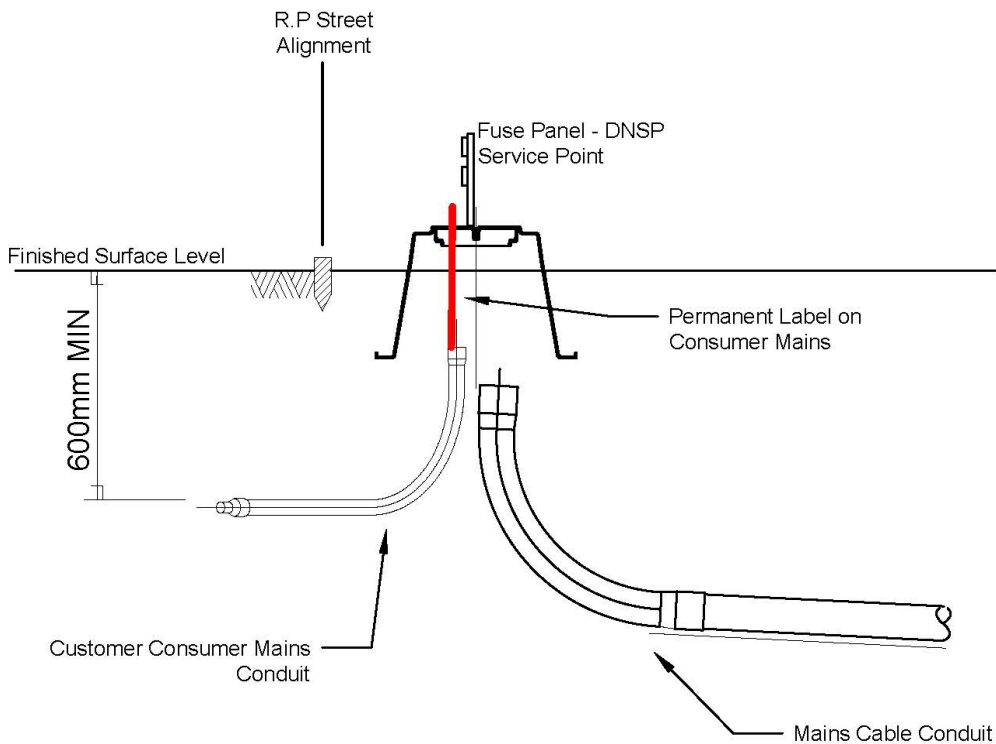

**Figure 3 Typical UG LV service pillar**

## 7.6.3 Consumer mains and conduit

### 7.6.3.1 General

- (a) The *Electrical Contractor* shall install the *consumer mains* and conduit into the service pillar for connection to the *DNISP service point* by the *DNISP* personnel. Figure 3 shows a basic representation of a consumers conduit connection arrangement into a typical *LV UG* service pillar connection.
- (b) As per clause 7.2 (c) only the *DNISP* shall install, connect, alter, remove, or relocate an *UG DNISP service point*. See clause 4.7 for more detail on authorised activities and non-authorised activities.
- (c) *Consumer mains* cables shall meet the following requirements:
  - (i) aluminium or copper cables; and
  - (ii) no greater than the maximum number and size in Table 34; and
  - (iii) polymeric insulated or sheath cables as per AS/NZS 3000.
- (d) To allow the *DNISP* personnel to connect the *consumer mains* cables, the *Electrical Contractor* shall prepare the *UG consumer mains* with terminations that meet the following requirements:
  - (i) conductors are lugged as required;
  - (ii) for aluminium cable, termination with suitable bi-metallic connectors for connection to fuses and neutral link.
  - (iii) *Consumer mains* larger than the maximum consumer mains size in Table 34 and clause 7.6.3.6 for connection at the *point of attachment* shall be reduced in compliance with AS/NZS 3000 and clause 7.6.3.7.
- (e) *UG consumer mains* shall be identified and labelled as per clause 8.2.2.
- (f) The route of the *UG consumer mains* is to be identified in accordance with AS/NZS 3000.

### 7.6.3.2 Cross road and supply pillars

- (a) Cross road and supply pillar *consumer mains* and conduits shall meet the requirements of clause 7.6.3.1.
- (b) For cross road and supply pillars the *Proponent* installs the *consumer mains* and conduit in a manner where:
  - (i) the conduit shall not protrude past the pillar base; and
  - (ii) the conduit shall be positioned to the rear of the fuse panel; and
  - (iii) the minimum length of the *consumer mains* shall be sufficient to reach the top of the fuse panel plus an additional 300 mm.
- (c) In Ergon Energy Network *distribution system* area, for cross road and supply pillars a Lead In (service) conduit is provided at the *DNISP service point* which the *Electrical Contractor* shall use for the installation of the *consumer mains*. *Consumer mains* shall only be installed via the Lead In (service) conduits provided. The Lead In (service) conduit has the following characteristics:
  - (i) The Lead In conduit is 40 mm and a 25 mm reducer is provided on each Lead In conduit. The reducer can be removed and replaced as necessary; and
  - (ii) each Lead In (service) conduit exits the pillar at a 45-degree angle; and
  - (iii) the Lead In (service) conduit is 600 mm deep and identifiable with orange caution tape tied to the end of the conduit extending to ground level for ease of location.

### 7.6.3.3 C & I pillars

- (a) C & I pillar *consumer mains* and conduits shall meet the requirements of clause 7.6.3.1; and

- (b) the maximum width of *UG consumer mains* lug terminations for C & I pillars is 38 mm to fit a M12 bolt.

### 7.6.3.4 Distribution cabinets

- (a) Distribution cabinet *consumer mains* and conduits shall meet the requirements of clause 7.6.3.1.
- (b) The maximum width of *UG consumer mains* lug termination for distribution cabinet is 38 mm to fit a M12 bolt.

### 7.6.3.5 Distribution transformer with *point of attachment* at distribution transformer LV terminals

- (a) The *consumer mains* and conduits connecting to distribution transformers with the *point of attachment* at the distribution transformer LV terminals, shall meet the requirements of clause 7.6.3.1.
- (b) Where *consumer mains* are to be connected at the distribution transformer LV terminals they shall be:
  - (i) adequately supported; and
  - (ii) be connected to the transformer terminals by flexible braid connectors and adaptor plates<sup>15</sup>.

### 7.6.3.6 Distribution transformer with *point of attachment* at LV switchgear

- (a) The *consumer mains* and conduits connecting to distribution transformers with the *point of attachment* at either the distribution transformer LV fuses or LV isolator, shall meet the requirements of clause 7.6.3.1.
- (b) Where *consumer mains* size to be connected at the distribution transformer LV fuses or LV isolator shall be restricted to maintain clearances between phases when physically connected. The standard switch fuse unit in a padmount substation distribution transformer permits a maximum of 2 x 300 mm<sup>2</sup> aluminium or copper cables per phase.

### 7.6.3.7 Joints in *consumer mains*

Joints in un-metered *consumer mains* are permitted provided they comply with AS/NZS 3000 and are not vulnerable to tampering by re-instating insulation to equivalent of an unbroken cable.

## 7.7 Non-standard *UG* connection arrangements

The following arrangements are non-standard and shall be subject to limited access or assessed for technical limitations identified on a case-by-case basis.

### 7.7.1 *UG DNSP service point* from *OH* service area

- (a) A *Proponent* may request approval for the *DNSP* to provide a *UG DNSP service point* from an *OH* service area as per clause 4.8; and
- (b) the *DNSP* may offer a *Proponent* an *UG DNSP service point* from an *OH* service area where the *Proponent* requests to alter, extend, or relocate the point of origin of the *DNSP service point*, associated *connection assets* or *service line*.
- (c) Where a *UG DNSP service point* connection offer is approved under (a) or (b):
  - (i) the *DNSP service point* location shall comply with clause 7.3 (a);
  - (ii) the *point of attachment* and *connection point* shall comply with Table 33;

---

<sup>15</sup> For more information refer to Energex Commercial and Industrial Substation Manual or Ergon Energy Network Indoor Distribution Substation Design Standard.

- (iii) *UG* pillar requirements are specified in clause 7.6.2;
- (iv) all costs incurred will be charged as per clause 5.2.2.

## 7.7.2 CBD

The *distribution system* of the Brisbane CBD and fringe suburbs of the Brisbane CBD has limitations on *distribution system* infrastructure fault ratings. A *Proponent* requesting approval to connect or alter an existing connection may:

- (a) be required to meet equipment or facility specifications specific to Brisbane *CBD* and fringe suburbs of the Brisbane CBD.
- (b) be required to demonstrate how the connection will not effectively contribute to a rise in the fault level at the *DNSP service point*.

## 7.7.3 Pit

- (a) *UG* pits are in use in only limited areas in the *distribution system* service areas.
- (b) A *Proponent* may request approval to connect to into an existing *UG* pit.
- (c) *UG* pit *consumer mains* and conduits shall meet the requirements of clause 7.6.3.1.
- (d) Only sealed lugs and glue lined heat shrink shall be used for terminations in the *UG* pit as it is submersible and will result in water ingress and subsequent equipment failure.

## 7.8 Connection to interim structure during construction

A *Proponent* may use an interim structure for connection of underground *consumer mains* while undertaking construction activities at a *premises*. Use of an interim structure shall meet the following requirements:

- (a) Meet the design and construction requirements in drawings QCD07-01;
- (b) have a metered supply; and
- (c) the *connection point* is to be as per clause 7.6.1(b).

## 8 *Electrical installation requirements*

### 8.1 General

- (a) Section 8 applies to *LV* connections only. *HV* electrical connections shall comply with STNW3522 Standard for Major *Customer* Connections, *DNISP* documentation provided during the connection application process and the connection agreement.
- (b) The *DNISP* may require additional *electrical installation* requirements where connections are made in constrained network areas including non-standard networks (*CBD*, *SWER* and *isolated networks*).
- (c) *Electrical installations*, *electrical equipment* and associated structures designed for connection to the *distribution system* shall comply with AS/NZS 3000, AS/NZS 3010, AS/NZS 3100 and AS/NZS 4777.1.

### 8.2 Labelling, identification, and signage

#### 8.2.1 General

The following requirements apply to labels, identification and signage where required under this *manual*:

- (a) they shall be made of material shall be able to withstand ultraviolet radiation, extreme weather, and vandalism; and
- (b) they shall be indelible, durable, legible, and suitably secured for the expected life of the installation; and
- (c) technical guidance should be taken from AS 1319.

#### 8.2.2 *Consumer mains* conductor labelling and identification

- (a) To support safe connection to the *distribution system* at the *UG DNISP service point* the *Proponent* shall clearly identify and label the *consumer mains*:
  - (i) at the *DNISP service point*; and
  - (ii) so that the label is fixed to the outer sheath of the cable in a position that is visible without undue manipulation of the termination or the need for excavation.
  - (iii) the *consumer mains* shall be labelled with the correct street address as registered with local Council (lot number and street name) for the *premises* it is intended to supply once connected to the *distribution system*.
- (b) To allow identification of conductors and correct phase sequence of polyphase meters, the individual conductors of *consumer mains* shall be clearly identified:
  - (i) at *point of attachment* and up to and including each set of metering isolation links by colour coding of the conductor insulation (e.g., red, white, and dark blue to identify active conductors); and
  - (ii) this identification may be achieved by installation of 150 mm minimum of colour coded sleeving installed at the *consumer mains* terminations at the *point of attachment*; and
  - (iii) insulation tape is not an acceptable means of identification.
- (c) Labelling should be compliant with clause 8.2.1 and AS/NZS 3000.

#### 8.2.3 Metering active link and metering neutral link labelling

- (a) The metering active link and metering neutral link shall be labelled:
  - (i) with a permanent label is required on the front of the meter panel to indicate the location of the metering active links and metering neutral links;

- (ii) the links shall be identified as metering active link and metering neutral link respectively; and
- (iii) the links shall be marked to identify which meter is fed from each outgoing circuit of the link.

(d) Labelling should be compliant with clause 8.2.1 and AS/NZS 3000.

## 8.2.4 *Small IES* labelling and signage

Labels and signs on the *small IES*, including cables, shall meet the requirements of AS/NZS 4777.1, AS/NZS 3000, AS/NZS 5033 and AS/NZS 5139.

## 8.2.5 *Premises with multiple services*

*Premises* with multiple services shall have labelling, identification, and signage in compliance with clause 8.2.1 and clause 5.6.3.

## 8.3 Voltage

- (a) A *LV electrical installation* shall be designed and installed to operate under the supply voltage and range seen in Table 35 at the *DNSP service point*.

**Table 35** *LV supply voltage*

Voltage	Voltage range
230 V (line to neutral)	+10% / -10%

- (b) A *Proponent* shall design and operate *LV electrical installations* at a *premises* to meet the voltage drop and voltage rise requirements in Table 36.

**Table 36** *LV voltage drop, and voltage rise for LV electrical installations at a premises*

Parameter	Measured	Requirement
Voltage drop	From the <i>DNSP service point</i> and any point in the <i>electrical installation</i>	$\leq 5\%$ <sup>1</sup>
Voltage rise <sup>2</sup>	From the <i>DNSP service point</i> to the inverter AC terminals	$\leq 2\%$

Note 1 – Where in accordance with AS/NZS 3000, the *DNSP service point* is the *LV* terminals of a distribution transformer located on the *premises* of the *electrical installation* and dedicated to the installation, the permissible voltage drop may be increased to 7%.

Note 2 – For *EG systems* as specified in AS/NZS 4777.1

## 8.4 Phase balancing

A *Proponent* shall design, select equipment, and operate a multi-phase *electrical installation* to meet the following phase balancing requirements:

- (a) The current in any phase shall not exceed the current in any other phase by more than 20 A at the *connection point*.
- (b) Primary tariff loads shall be balanced across all supplied phases.
- (c) Any controlled tariff shall be balanced across phases.
- (d) A controlled tariff or time of use tariff shall not be used to balance another tariff across phases.
- (e) Equipment selection shall meet the requirements of clauses 8.14.2 and 8.15.1.
- (f) Phase balancing of *EG systems* shall meet the requirements in the *EG* connection standards.

## 8.5 Determining system limits

### 8.5.1 General

- (a) Where there are multiple connected and proposed *EG systems* at a *premises* through a single *connection point*, the system capacity is the aggregate of all generation.
- (b) Generation control, including *dynamic* and fixed *export* and *import* limits for *dynamic EG* systems shall apply as per *EG* connection standards in clause 8.15.1.
- (c) For non-standard connections where a Proponent multiple *connection points* at a *premises*, the system capacity is the aggregate of the generation of all the existing connected and proposed *EG* systems at the premises across the *connection points*.

### 8.5.2 EVSE dynamic and fixed import limits

#### 8.5.2.1 General

The *import* limits of *EVSE* on a *dynamic* connection shall meet the following requirements:

- (a) *Dynamic EVSE* has two fixed *import* limit types:
  - (i) a fixed *import* limit; and
  - (ii) *dynamic import* limits.
- (b) The fixed *import* limit, as per Table 44, will be met at all times when *EVSE* on a *dynamic* connection is not receiving or able to respond to a *dynamic import* limit.
- (c) The *dynamic import* limits are supplied by the *DNSP* to *EVSE* on a *dynamic* connection. The *dynamic import* limit supplied will be no less than the minimum and no more than the maximum shown in Table 44.
- (d) The *import* limits shall meet the measurement and control requirements in clauses 8.5.2.2, 8.5.2.3 and 8.5.2.4.
- (e) The *DNSP* may require reduced limits for individual premises where multiple premises are connected to a single *DNSP service point*.
- (f) Availability of *import* limits above the minimum *dynamic import* limit in Table 44 are subject to availability of *distribution system* capacity.
- (g) The *Proponent* shall not exceed the maximum supply limits in this *manual* or within the *Customer* connection contract for supply.
- (h) The *import* limits for *dynamic EVSE* are for all *EVSE* at the *connection point*.

#### 8.5.2.2 Measurement of import limits

The reference point for the measurement of *import* limits shall be:

- (a) Measured at a point as close to the *connection point* as practicable, referencing a single point beyond the *connection point* within the *Proponent's premises*.
- (b) Connected at a location that has a lower impedance to the *connection point* than any *EG unit* connected within the *Proponent's premises*.

#### 8.5.2.3 Measurement of device compliance

The instrument transformers used to interface the equipment used to manage *import* limits for the *Proponent's premises* shall have certified compliance with:

- (a) AS 61869.1 General requirements;
- (b) AS 61869.2 Additional requirements for current transformers;
- (c) AS 61869.3 Additional requirements for inductive voltage transformers;
- (d) AS 61869.4 Additional requirements for combined transformers.

## 8.5.2.4 Control of *import* limit

- (a) The control function for *import* limitation shall meet the following requirements:
  - (i) Have a limit that will cause the *dynamic EVSE* to reduce its consumption, preventing *import* at the *connection point* greater than the *import* limit.
  - (ii) Where the *import* limit is exceeded, the *import* control function shall operate to ensure the *dynamic EVSE* meets the *import* conditions, or otherwise ceases charging, within 15 seconds.
  - (iii) The *import* control device settings shall be secured against inadvertent or unauthorised tampering. Changes to settings shall require the use of a tool and special instructions not provided to unauthorised personnel.
- (b) Where the *import* control function loses connection with an external device, or detects any fault or loss of operation of the *import* control function, it shall reduce *import* to the fixed *import* limit.
- (c) The *import* limit shall apply to all of the *EVSE* connected within the *premises*. Total *import* at the *connection point* to the *electrical installation* will remain within the limits described in the *Customer* connection contract.
- (d) The ability of the *Proponent's EVSE* to *import* at the limits described in Table 44 are not guaranteed and will depend on the characteristics of the *distribution system* from time to time.

## 8.6 *Distribution system* fault levels

- (a) Any *electrical equipment* that is connected (directly or indirectly) to the *distribution system* shall be designed to safely withstand the range of operating conditions that may arise at the *connection point*.
- (b) A *Proponent* shall ensure that any circuit breakers or switchgear on the load side of the *connection point* that isolate the *premises* from the *distribution system* are sufficiently rated to safely break the fault currents (both active and reactive) that may occur on the *distribution system*.
- (c) Maximum three-phase fault currents on the *LV* terminals of a distribution transformer based on nameplate rating is shown in Table 37.

**Table 37 Maximum three-phase fault currents on *LV* terminals of a distribution transformer**

Nameplate rating (kVA)	Transformer type	Transformer nominal impedance (%)	Maximum <i>LV</i> three-phase fault current (kA)
25	Pole mount	3.30	1.1
63	Pole mount	4.00	2.3
100	Pole mount	4.00	3.7
200	Pole mount	4.00	7.4
315	Pole mount and Padmount	4.00	11.7
500	Pole mount and Padmount	4.00	18.5
750	Padmount	5.00	22.2
1000	Padmount	5.00	29.6
1500	Padmount	6.25	35.6

Note 1 – Maximum fault currents are based of network equipment which may vary when standard products are updated. A Proponent should consider appropriate design margins and may determine certain applications require a site-specific fault level assessment which can be accessed via the relevant DNSP enquiry form in Appendix N.

- (d) To determine a transformer size used on the *distribution system* use the look up and live app or for newer transformers:
  - (i) Pole mount - written on the transformer tank and is visible from the ground.
  - (ii) Padmount - written on the transformer tank.
- (e) LV fusing information can be found in the *DNSP OH* and *UG* construction manuals in clause 3.1.1, available on the DNSP websites in Appendix N. Note that older and non-standard transformer constructions may have different LV fuse sizing.

## 8.7 Protection

### 8.7.1 General

- (a) The *DNSP's* (HRC) LV service fuse rated up to 100 A will provide suitable fault current limiting for a *Proponent's electrical installation*.
- (b) For LV supplies the *DNSP* service fuse shall not be considered as overload protection for the *consumer mains*.
- (c) Installation of fault current limiters may be required to protect direct connected metering on the *Proponent's electrical installation*, refer to clause 10.2.3(e).

### 8.7.2 Protective fault current devices

- (a) Protective fault current devices installed by the *Proponent* shall have an interrupting capacity adequate for the prospective short circuit current at the point of *electrical installation*.
- (b) In the event of the fault current being increased at any point on an installation because of provisions for additional load, the *Proponent* shall be responsible for the upgrading of all equipment not rated for the prospective fault level.
- (c) Refer to clause 8.6 to determine *DNSP* fault currents based on *connection assets*.

### 8.7.3 Main switch

#### 8.7.3.1 General

- (a) The *Proponent* shall design the *electrical installation* to include a main switch.
- (b) The main switch primary function shall be to isolate the *electrical installation* in compliance with AS/NZS 3000.

#### 8.7.3.2 Circuit breaker required in *rural areas* and *isolated networks*

For *rural areas* and *isolated networks*:

- (a) The *DNSP* shall require installation of a circuit breaker(s) for a main switch(s) as part of the *Customer's electrical installation*.
- (b) The main switch(s) circuit breaker(s) are required to coordinate with the:
  - (i) service fuse; or
  - (ii) service circuit breaker.
- (c) The *DNSP* may require the *Customer's* protective device to be changed or altered to provide adequate discrimination.<sup>16</sup>

---

<sup>16</sup> as per Section 29 and 30 of the Electricity Regulation 2006 (Qld).

## 8.8 Earthing

### 8.8.1 General

*Electrical installations* shall comply with the *MEN* earthing system as specified in AS/NZS3000.

### 8.8.2 Earthing for *premises* with multiple *DNSP* service points

Only one *MEN* shall be allowable for the collective group of interconnected building, structures and/or *electrical installations* where a *Proponent* is:

- (a) supplied by more than one *DNSP* service points; and
- (b) more than one *DNSP* service point supplies a building, structure, *electrical installation*, or group where there is interconnection through the earthing system that forms part of the *MEN*.

### 8.8.3 Earthing for distribution transformers on *premises*

- (a) The *Proponent* shall meet the requirements of clause 8.8.1 and clause 8.8.2.
- (b) For a *Proponent's* supplied by a distribution transformer on their *premises* under clause 4.5.3.1 the *Proponent's* shall not bond to the *DNSP* earth.
- (c) To provide safe clearance for a buried earthing system from a distribution transformer where a *Proponent* is required to supply space for a distribution transformer on their *premises* under clause 7.4, a *Proponent* shall either:
  - (i) ensure building foundations, the *Customer's electrical installation* LV earths and all metallic structures are located a minimum of 5 m from a *DNSP* HV earthing system. The *DNSP* will provide advice on the location of the HV earthing system for specific installations if required; or
  - (ii) provide the *DNSP* with an *easement* or indentation of road reserve in favour of the *DNSP* to dimensions required by the *DNSP* prior to connection. An indentation of road reserve can be referred to as a cut-out or extension of road reserve.

## 8.9 Power quality

### 8.9.1 General

- (a) *Proponents* shall design *electrical installations* to prevent any connected device or system interfering with supply of electricity to any user of the *distribution system*. A *Proponent* shall consider the impact of particular loads such as transformer arc welding machines, motor starting, fluorescent lighting as well as *EG systems* connections.
- (b) The requirements of AS/NZS 61000 series standards "Electromagnetic Compatibility (EMC)" shall be applied to all connections.
- (c) In a case where the *DNSP* may have connected the equipment or device causing the interference, the *Proponent* is not exempt from this clause.

## 8.9.2 Power factor

- (a) A *Proponent* shall ensure that the power factor measured at the *connection point* of any *electrical installation*:
- (i) under normal load conditions is compliant with the applicable range in Table 38; and
  - (ii) demonstrates compliance with the relevant *EG system* standards in clause 8.15.1; and
  - (iii) is not less than 0.8 lagging.

**Table 38 Power factor performance standard**

Nominal supply voltage <sup>1</sup>	Power Factor range
50kV - 250kV	0.95 lagging to unity
1kV <50kV	0.90 lagging to 0.90 leading
<1kV	>0.8 lagging but not leading

Note 1 - At all other voltage ranges the requirements are as specified by the *NER*, unless detailed in a contract.

- (b) Where an *electrical installation* does not meet the requirements of clause 8.9.1(a) or (b) the *Proponent* shall be responsible for taking appropriate power factor correction actions:
- (i) to ensure compliance; and
  - (ii) as approved by the *DNISP*.
- (c) Power factor correction equipment shall:
- (i) be installed on the load side of metering equipment and main switch; and
  - (ii) where shunt capacitors are installed, the design avoids attenuating the *DNISP*'s audio-frequency signals used for load control as per clause 10.6.5.5.

## 8.9.3 Harmonic emissions

*Customers* shall meet the harmonic emission limits specified for their *electrical installation*, even under resonant conditions due to their capacitor bank.

## 8.9.4 Harmonic interference or waveform distortion

The *DNISP* reserves the right to specify the conditions under which an electricity supply will be given for equipment which would cause excessive distortion to the wave form of the supply system voltage for *electrical equipment* including but not limited to rectifiers, frequency converters, load control devices using thyristors or saturable reactors.

## 8.9.5 Rectifiers

- (a) Alternating to direct current rectifying equipment shall not be connected to the *distribution system* unless:
- (i) the rectifier is of the full-wave type; or
  - (ii) a double-wound transformer is interposed between the rectifier and the *distribution system*; or
  - (iii) the rectifier is used in conjunction with an electrical measuring instrument or in similar applications where the rectified current does not exceed 100 mA.
- (b) Information on general limits may be obtained from AS/NZS 61000 series on Electromagnetic Compatibility (EMC).

- (c) A *Proponent* shall avoid harmonic interference to the *DNSP's* audio frequency control system as per clause 10.6.5.5.

## 8.10 Active device management

### 8.10.1 General

- (a) *Electrical equipment* may be installed and configured to achieve *active device management* control outcomes.
- (b) *Electrical equipment* may be required to meet *active device management* control outcomes as per this *manual* or other connection agreement conditions or requirements.
- (c) The *active device management* mechanisms by type are shown in Table 39 below:

**Table 39 Active device management options**

Active device management classification	Mechanism	Clause
Type 1	<i>Emergency backstop mechanism</i>	8.10.2
Type 2	Controlled tariff via <i>network device</i>	9.2, 10.6
Type 3	PeakSmart	8.10.3
	<i>Dynamic</i>	8.10.4
	Basic active management via <i>network device</i>	8.10.5, 10.6

Note 1 – *Electrical equipment* installed with compliant Type 2 and Type 3 *active device management* mechanisms are eligible for larger device switched load limits, see clause 8.14.2.2.

### 8.10.2 Emergency backstop mechanism

The following requirements apply to a *GSD* for *EG* Systems that are to have an *emergency backstop mechanism* under a relevant *EG* connection standard in clause 8.15.1:

- (a) The *GSD* shall be installed in compliance with AS/NZS 3000.
- (b) A connection with an individual inverter that is required under an *EG* connection standard in clause 8.15.1 to have a *GSD* shall meet the requirements of the relevant drawing, based on aggregate inverter capacity at the *premises*, as per Table 40:

**Table 40 GSD for individual inverter**

Aggregate inverter capacity at <i>premises</i> <sup>1</sup>	Drawing number
≥ 10 k VA and ≤ 30 kVA	QCD05-01
> 30 kVA	QCD05-04

Note 1 – Including inverters with ESS DC sources

- (c) A connection with multiple inverters that are required under an *EG* connection standard in clause 8.15.1 to have a *GSD* shall meet the requirements of the relevant drawing, based on aggregate inverter capacity at the *premises*, as per Table 41:

**Table 41 GSD for multiple inverters**

Aggregate inverter capacity at <i>premises</i> <sup>1</sup>	Drawing number
≥ 10 k VA and ≤ 30 kVA	QCD05-02 or QCD05-03
> 30 kVA	QCD05-05, QCD05-06 or QCD05-07

Note 1 – Including inverters with ESS DC sources

- (d) The *GSD* shall be located in either:
  - (i) the main switchboard; or
  - (ii) the distribution board with the protective device for inverter supply.
- (e) Where the aggregated system capacity of all inverters at the *premises* is above 30 kVA, the *GSD* shall be installed in parallel with the Grid Protection Relay (GPR) in a fail-safe configuration.
- (f) The *GSD* control cable may be extended as required.
- (g) The *GSD* control cable shall connect:
  - (i) directly to the inverter;
  - (ii) to the inverter via the external device used to provide *demand response* mode, where the inverter does not have an integrated device; or
  - (iii) to the inverter via a *demand response site controller* where compliant with the relevant drawing, based on aggregate inverter capacity at the *premises* as per Table 42.

**Table 42 GSD with *demand response site controller* for multiple inverters**

Aggregate inverter capacity at <i>premises</i> <sup>1</sup>	Drawing number
≥ 10 k VA and ≤ 30 kVA	QCD05-03
> 30 kVA	QCD05-06 or QCD05-07

Note 1 – Including inverters with ESS DC sources

- (h) Where a wireless communication channel or device is enabled for the *demand response site controller* as per the requirements of drawing QCD05-07, the communication link shall meet the following requirements:
  - (i) have a supervised wireless communications link; and
  - (ii) have a communication delay that does not exceed 0.5 seconds; and
  - (iii) disconnect the inverters from the *distribution system* for any loss of communications longer than 5 seconds.

### 8.10.3 PeakSmart

- (a) PeakSmart air conditioners require a 'Demand Response Enabling Device' (*DRED*) to be connected to the air conditioner at an *electrical installation* by the *Proponent*.
- (b) PeakSmart is an incentive-based program for air conditioners for cooling capacity (kW). The cooling capacity is the output of the air conditioner and not the input power. The input power should be referred to when determining compliance under clause 8.14.2.

- (c) When the *distribution system* reaches peak demand the *DNISP* sends a signal to the *DRED* via *AFLC* as per clause 10.5.5.5.
- (d) The demand response modes for PeakSmart operate in accordance with AS/NZS 4755.3.1.
- (e) To ensure performance in compliance with (b) and (c) a *Proponent* shall install the PeakSmart in compliance with:
  - (i) drawing QCD05-08; and
  - (ii) the manufacturers installations instructions<sup>17</sup>; and
  - (iii) the installation guidance.

## 8.10.4 Dynamic

- (a) Technical requirements, maximum and minimum *dynamic* capacities and fixed limits for *dynamic EG* systems are specified in *EG* standards as per clause 8.15.1.
- (b) *EVSE* on a *dynamic* connection shall be capable of sending and receiving information via *SEP2* using *CSIP-AUS* directly or via a third party.
- (c) *EVSE* on a *dynamic* connection is enabled for *dynamic* operation where it meets the requirements of clause 13.2.
- (d) *EVSE* capable of *dynamic* operation shall meet the limits as specified in Table 43 below. Import limits are based on the aggregated import of all load at the *DNISP service point*.

**Table 43 Dynamic EVSE limits**

	Fixed <i>import</i> limit / minimum dynamic import limit	Maximum dynamic import limit
single-phase	≤ 4 kW	≤ 15 kW
two-phase	≤ 4 kW	≤ 10 kW/phase
three-phase	≤ 4 kW	≤ 15 kW/phase

- (e) *EVSE* on a *dynamic* connection shall meet the communication systems requirements in clause 8.11 and the data and information requirements in clause 8.12.
- (f) *EVSE* on a *dynamic* connection shall meet the *dynamic* and fixed *import* limit requirements in clause 8.5.2.
- (g) Bi-directional *EVSE* to enable V2G shall meet the *import* and *export* limit criteria under the *EG* connection standards as per clause 8.10.4(a).

## 8.10.5 Basic active management via *network device*

*EVSE* may be installed in *electrical installations* with basic active management via a *network device* as per the following requirements:

- (a) For *electrical installations up to* for 100 A/phase; and
- (b) In compliance with clause 10.6 and drawing QDC08-01.

## 8.11 Communication systems

### 8.11.1 General

- (a) Dynamic equipment or *EG system* shall support the sending and receiving of information to the *DNISP* with communication systems that meet the following requirements:

<sup>17</sup> <https://www.tmacgroup.com.au/wp-content/uploads/2022/10/TM-UI-043-DCSR-Installers-Manual.pdf>

- (i) Connection of the *dynamic* equipment or *EG system* to the public internet.
  - (ii) Compliance with *SEP2* using *CSIP-AUS*.
- (b) Where a *GSD* is required as an *emergency backstop mechanism*, an inverter is configured to enable functionality of the *demand response* mode DRM 0 in compliance with AS/NZS 4777.2 to receive signals via Audio Frequency Load Control (*AFLC*).

## 8.11.2 Connection of communications system

- (a) The communication systems for a *dynamic* equipment or *EG system* shall be met by one of the following methods of connection for information exchange via *SEP2* using *CSIP-AUS*:
- (i) direct connection of a *dynamic* equipment or *EG system*;
  - (ii) third-party device which communicates with the *dynamic* equipment or *EG unit(s)*; or
  - (iii) cloud based vendor which communicates with the *dynamic* equipment or *EG unit(s)*.

## 8.11.3 Information exchange

- (a) The communications system shall be able to support sending and receiving information with the following frequency and capacity:
- (i) frequency of no less than 5 minutes; or
  - (ii) forecast information shall be provided for up to 24 hours, with the supply of 5-minute forecasts for the next immediate hour and 1 hourly forecasts for the next 23 hours.

## 8.12 Data and information

### 8.12.1 Static data and information

Static data and information shall be provided by the *Proponent* to the *DNSP* in accordance with Appendix D.

### 8.12.2 Dynamic data and information

*Dynamic* data and information that is required to be provided by the *Proponent* to the *DNSP* as per Appendix E.

## 8.13 Cyber security

This Section has been left intentionally blank.

## 8.14 Load connections

### 8.14.1 Determining maximum demand

The maximum demand of an installation shall be calculated, measured, or assessed in accordance with the guidelines set out in AS/NZS 3000.

### 8.14.2 Equipment selection

#### 8.14.2.1 General

- (a) Appliances and *electrical equipment* shall be selected in compliance with AS/NZS 3000 and AS/NZS 4777.1 with, Australian and International Standards.
- (b) All equipment must be able to operate satisfactorily within the voltage limits detailed in the applicable legislation or regulation as per clause 8.3.
- (c) Equipment selection for connection in *isolated networks* take into consideration the requirements in clause 5.9.1.
- (d) A *Proponent* is responsible for ensuring *electrical equipment* selection meets requirements for safety, reliability, power quality, maintains any eligibility criteria for tariffs and meets the

requirements of this *manual*. The *DNSP* is not liable for any losses related to a *Proponent's* selection of equipment where equipment is not able to be connected to the *distribution system*, any tariffs are lost or other consequential losses.

- (e) Only approved devices shall be connected to the *distribution system*.

## 8.14.2.2 Switched loads

- (a) Switched loads are any loads that can be switched on and off or between operational settings.
- (b) *Electrical equipment* installed and configured to achieve active device management control outcomes Type 2 and Type 3, shall meet the requirements of clause 8.10.
- (c) All equipment designed to be installed in *electrical installation* of 100 A per phase or less shall be installed in accordance with Table 44.

**Table 44 Switched load equipment current limits**

Equipment	Switching arrangement	Phase	Limit (A) <sup>2</sup>
230V equipment – general		1 (line to neutral)	20
	Phases not switched simultaneously	2 or 3 (line to neutral)	20
	Phases switched simultaneously	3 (line to neutral)	40
230V equipment – with <i>active device management</i> Type 2 and Type 3 <sup>1</sup>		1 (line to neutral)	35
	Phases not switched simultaneously	2 or 3 (line to neutral)	35
	Phases switched simultaneously	3 (line to neutral)	50
Commercial cooking equipment		1 (line to neutral)	35
	Phases not switched simultaneously	2 or 3 (line to neutral)	35
	Phases switched simultaneously	3 (line to neutral)	40

Note 1 – *Electrical equipment* may have both Type 2 and Type 1 or Type 3 and Type 1 *active device management options* (refer to clause 8.10.1); for these cases the higher current limits apply in this Table.

Note 2 – Limit is based on nameplate rating of *electrical equipment*.

- (d) When assessing domestic cooking equipment for compliance to 230 V uncontrolled equipment limits or 230V controlled equipment limits, assessments may be completed in accordance with AS/NZS3000 Appendix C2.5.3 for Domestic Cooking Appliances.
- (e) For the suitability of water heaters for load control supplies reference should be made to the *Network Tariff Guide* (available from the *DNSP's* website in Appendix N) e.g., where the heating unit rating exceeds 1800 W, it shall not exceed 13.5 W per litre of heat storage

volume for heat exchange type water heaters or 15.5W per litre of rated hot water delivery for other storage type water heaters.

- (f) Electric vehicle supply equipment shall be compliant with AS/IEC 62196.

## 8.14.3 Equipment with fluctuating load

- (a) The *DNISP* reserves the right to specify the conditions under which an electricity supply will be given for equipment having rapidly fluctuating loads such as welding machines, other than welding machines complying with AS 60974.6, or previous standards superseded by this standard, and marked "Limited Input", x-ray equipment and furnaces.
- (b) No work should be carried out by a *Customer* to connect equipment with fluctuating load until advice has been received on the terms on which supply will be given as per clause 8.9.

## 8.14.4 Electric vehicle supply equipment

- (a) Electric vehicle supply equipment (*EVSE*) that is only capable of charging from the grid shall meet the requirements of load connections under this *manual*.
- (b) Equipment selection for *EVSE* shall meet the requirements of clauses 8.14.2.1 and 8.14.2.2.
- (c) Where *EVSE* is capable of exporting energy into the *Customers premises* or the *distribution system* it shall be considered part of a *EG* connection. *EG* connected *EVSE* is referred to as Vehicle-to-Grid (*V2G*), and requirements can be found in clause 18.16.2.

## 8.14.5 AC motors

### 8.14.5.1 General requirements

- (a) Where calculating requirements, the motor rating in kW is the continuous rating of the largest motor in the installation.
- (b) Except for the special provisions considered in clause 8.14.5.4, motor installations and any associated starting devices shall be so designed and operated as to comply with Table 45 or Table 46.
- (c) A *Proponent* requires approval from the *DNISP* to install motors in *SWER* areas of supply prior to installation as per clause 4.8.

**Table 45 Single phase motors**

Voltage (V)	Motor size (kW)	Allowable starting current (A)
230 V	All sizes	45 A
400 V	≤ 7.5 kW	$I = (17.5 \times \text{motor rating in kW}) \text{ A}$
	> 7.5 kW	Shall not be connected

**Table 46 Three phase motors 400 V**

Motor size (kW)	Allowable starting current (A)
≤ 1.5 kW	26 A
> 1.5 kW and ≤ 3.5 kW	$I = (17.5 \times \text{motor rating in kW}) \text{ A}$
> 3.5 kW ≤ 10 kW	$I = (53 + 3.3 \times \text{motor rating in kW}) \text{ A}$
> 10 kW	Contact <i>DNISP</i> for limits

- (d) No limitation may be placed on the starting current of any motor that is not frequently started and the rated output does not exceed 10% of the total motor load connected for a *Proponent* to the one *DNISP* service point.

- (e) Motors should not be started simultaneously, and the starting current of the motors should be limited to 2 to 3 times full rated current by fitting with an appropriate starter.

## 8.14.5.2 Fall in voltage

The starting current shall not cause a fall in voltage of more than 5% of the nominal voltage at the *DNISP service point* for more than 0.02 seconds when connected to a typical 400/230V, three-phase, 50Hz supply system which for this purpose shall be considered to have the following impedance:

$$Z = 0.2 + j0.2 \text{ Ohms (phase - neutral).}$$

$$Z = 0.1 + j0.1 \text{ ohms (line impedance per phase).}$$

## 8.14.5.3 Test methods

- (a) Fall in voltage shall be measured by instrumentation with a high-speed measurement capability.
- (b) Starting currents shall be measured by instrumentation with a high-speed measurement capability or by the locked rotor method, with the rated voltage and frequency applied to the terminals of the motor.
- (c) In any case where the test methods specified in paragraphs (a) and (b) above cannot conveniently be applied, another test method that conforms to recognised practices in the electrical industry may be used.
- (d) The *DNISP* will accept test results from a recognised testing laboratory or manufacturer's certified test results.

## 8.14.5.4 Special provisions

- (a) For both three-phase and single-phase motors, where it is necessary for a *DNISP* to prevent interference with supply to other *Customers*, the *DNISP* may require a *Proponent* to:
  - (i) require maximum starting currents lower than those set out; or
  - (ii) limit the rating of any motor to be connected.
- (b) For *isolated networks* areas there are special limits on electric motors, including air conditioners. A *Proponent* may need to limit the size of equipment and may require time delay controls on motor starting circuits after a power outage. See clause 5.9.1 and Appendix G.2 for further information.

## 8.15 Generating system connections

### 8.15.1 Equipment selection

- (a) Generating units may be either inverter energy systems or rotating machines.
- (b) The *DNISP* standards requirements in Table 47 apply for inverters, rotating machines, and balance of plant for generating system connections:

**Table 47 EG connection standards**

Standard Number	Title
STNW1170	Standard for Small <i>IES</i> Connections
STNW1174	Standard for <i>LV EG</i> Connections
STNW3510	Dynamic Standard for Small <i>IES</i> Connections
STNW3511	Dynamic Standard for <i>LV EG</i> Connections
STNW3512	Standard for <i>LV EG</i> Connections to Isolated Networks

## 8.15.2 Design and installation

The installation of *Customer's* generating systems that is connected to and capable of operation in *parallel* with the *distribution system* shall comply with all relevant connection standards. The following minimum requirements shall be met:

- (a) The *consumer mains* neutral shall not be switched or broken on the distribution supply side of the *MEN* connection.
- (b) The generating system neutral is required to be clearly identified at the main neutral link.
- (c) Embedded generation is allowable from all forms of alternative energy supplies such as solar panel (photovoltaic), wind turbine, diesel generation in compliance with the relevant connection standard.
- (d) Appropriate metering will be installed in accordance with the negotiated supply arrangements.

### 8.15.2.1 Connection of *generating unit* in an *off-grid* arrangement

Where a *Customer* installs a *generating unit* at a *Customer's premises* to provide a supply of electricity to the *Customer's electrical installation*, during an interruption to *DNSP* supply, the following requirements shall be met:

- (a) The *Customer* shall ensure that, when the *generating unit* is operating to give emergency supply, it is installed with effective isolation between:
  - (i) all active conductors of the part of the *electrical installation(s)* to which the *generating unit* is connected; and
  - (ii) the part of the *electrical installation* still connected to the supply from the *DNSP*.
- (b) The connection of the *generating unit* shall be so arranged that the *Metering Provider's* revenue meters do not meter the alternate supply and all metering equipment, including CTs are able to be isolated to enable access whilst the generating system is in service.
- (c) Where the *generating unit* connects behind a *break-before-make* switch, that is, it isolates the changeover circuit when transferring between grid supply to generation supply, will be considered as an *off-grid generating unit*.
- (d) The *generating unit* is considered to be connected in *parallel* with the *DNSP's distribution system* and required to comply with all the requirements of the *EG connection standards* under clause 8.15.1 where:
  - (i) the *generating unit* is connected behind a make-before-break switch that results in a momentary, or longer, connection between grid supply and generation supply circuits when performing a changeover; or
  - (ii) a multiple mode inverter with uninterruptible power supply (UPS) mode functionality that is grid connected but also supplies an *off-grid* circuit.

### 8.15.2.2 *Parallel* connection of *EG system* with *distribution system*

For a *Proponent's EG System* for interconnection to the *distribution system*:

- (a) A *Proponent* shall not install *EG system* for interconnection with the *DNSP's distribution system* without prior agreement, which is to be documented in a written agreement.
- (b) The agreement shall include the conditions for securing safe and stable *parallel* operation of the supply network and the generating system as per Section 28 of the Electricity Regulation 2006 (Qld).
- (c) The generating system shall only be connected to a single tariff. A generating system shall not be enabled to connect and supply equipment which is being supplied on an alternate

tariff. Similarly, equipment connected to a control tariff shall not be connected to a tariff other than the control tariff.

## 8.16 Dual load and generating system equipment

### 8.16.1 General

*Electrical equipment* that has the properties of both a load device, appliance or product and a generating system is considered dual load and generating system equipment. A *Proponent* selecting the use of a dual load and generating system equipment shall meet the following requirements:

- (a) Ensure equipment meets certification requirements for the generating device, any connecting sources and the relevant appliance or product certifications.
- (b) Obtain connection approvals and contracts for both the load and generating capacities, ratings, and specifications of the equipment.
- (c) Only select equipment which has obtained jurisdictional approval required for the sale and installation of the *electrical equipment*.

### 8.16.2 Vehicle to Grid (V2G) EVSE

- (a) V2G EVSE shall meet:
  - (i) the EG connection standards in clause 8.15.1; and
  - (ii) the *electrical equipment* requirements in clause 8.14.2.1; and
  - (iii) the switched load requirements in clause 8.14.2.2.
- (a) Phase balance and phase balance protection requirements from AS/NZS 4777.2 shall apply to multi-phase *premises* with V2G EVSE. See the EG standards in clause 8.15.1 for detailed compliance requirements.

### 8.16.3 Battery energy storage system (BESS)

- (a) A grid connected battery *energy storage system* (BESS) is an *IES* and shall meet the requirements of the EG connection standards in clause 8.15.1.
- (b) Phase balance and phase balance protection requirements from AS/NZS 4777.2 shall apply to multi-phase *premises* with BESS. See the EG standards in clause 8.15.1 for detailed compliance requirements.

## 9 Network device and metering general requirements

### 9.1 General

- (a) *Proponent* shall comply with the requirements of Section 9 of this *manual* for *metering installations*.
- (b) *Metering installations* shall also comply with the *Metering Installation Requirements (MIR)*. In the event of any inconsistency between this *manual* (the *QECM*) and the *MIR*, both requirements shall be satisfied, if possible, otherwise this *manual* will prevail.
- (c) Unless otherwise specified, any references to metering in this *manual* refers to revenue metering.
- (d) Only the appointed *Metering Provider* can work on or remove metering equipment from a *Proponent's metering installation*.
- (e) Where a *Proponent* directs a *Retailer* to request metering or tariff changes, any alterations to the *Proponent's* switchboard installation or meter enclosure shall be the *Proponent's* responsibility (e.g., removal of asbestos contaminated waste).
- (f) *Proponents* shall also comply with additional requirements for *LV network devices* and metering and *HV* metering as specified in Section 10 and 11 respectively.
- (g) The *DNSP* shall supply and maintain *network devices* required to provide active management of electricity consumption where a *Proponent* has been deemed eligible for a controlled tariff. The *network device* shall remain at the *Proponent's* property.
- (h) All meter and *network device* active wiring shall be connected directly to the *Metering Isolation Link or Metering Active Link for direct connected installations*.
- (i) All phases of an *OH service line* are required to be connected at the initial connection of the *premises*.
- (j) All metering and control equipment shall be back-wired and mounted on a side hinged panel attached to a metering enclosure or a switchboard frame.
- (k) All the *Proponent's* ancillary equipment including (but limited to) surge diverters, voltmeters, phase failure relays, solar power monitors shall be connected on the load side of the metering equipment.
- (l) *Proponent* owned current transformers for energy management are permitted to be installed on the line side of metering equipment for multiple tenancy installations.

### 9.2 Network devices

#### 9.2.1 General

- (a) The *DNSP* may supply, install, and maintain the *network device* or devices in a *Proponent's meter board*:
  - (i) to provide active management of electricity consumption where a *Proponent* has been deemed eligible for a controlled tariff; and
  - (ii) to ensure safe and secure management of the *distribution system* as determined by the *DNSP*.
- (b) A *DNSP network device* shall remain at the *Proponent's* property.

#### 9.2.2 Provision of space for *network devices*

- (a) The *Proponent* shall provide and maintain at their expense, suitable space within the *meter board*, including an enclosure, mounting, and connecting facilities, to accommodate *DNSP network devices*.

- (b) The *Proponent* shall not interfere with a *DNSP network device*. The *Proponent* shall contact the *DNSP* to request consideration for removal of a *network device*.

## 9.3 Metering classification

The meter equipment type for a *metering installation* shall be selected for the *connection point* as per Table 48 based on voltage and either:

- (i) the measured current for the *electrical installation*; or
- (ii) the calculated maximum demand for the *electrical installation*.

**Table 48 Metering types**

Voltage	Metering equipment type	Measured Current (A)	Calculated Maximum Demand (A)
LV	Direct Current	≤ 80	≤ 100
	CT	> 80	> 100

Note 1 – Maximum demand calculated as per requirements of clause 8.14.1.

Note 2 – For *HV* metering see Section 11.

## 9.4 Authorised metering activities

### 9.4.1 General

- (a) For *LV* and *HV* installations a *Proponent* shall arrange to install metering by contacting an electricity *Retailer*.
- (b) *HV* installations including Type 1-3 *metering installations* as specified under Chapter 7 of the National Electricity Rules (*NER*).
- (c) For a *HV* connection a *Proponent* is responsible for supplying, installing, maintaining, and testing the *metering installation* including the instrument transformers in accordance with this *manual*.
- (d) The *Proponent* shall contact the *DNSP* prior to designing a *HV metering installation* as per clause 11.2.

### 9.4.2 DNSP activities

- (a) The *DNSP* does not provide contestable metering services on the main electricity grid.
- (b) The *DNSP* may provide, install, and maintain metering in accordance with this *manual* for a *Proponent* in an *Isolated Network*<sup>18</sup> or *Power of Choice Exempt areas*, where arranged by a *Proponent* through a *Retailer*.

### 9.4.3 Metering providers activities

A *Metering Provider (MP)* shall provide, install, and maintain metering in accordance with this *manual*, where arranged by a *Proponent* through a *Retailer*.

## 9.5 Provision of *meter board* and space to locate

- (a) The *Proponent* shall provide and maintain at their expense, suitable space, and a *meter board*, including an enclosure, mounting, and connecting facilities, to accommodate *network devices*, metering equipment and instrument transformers.

<sup>18</sup> [https://www.ergon.com.au/\\_data/assets/pdf\\_file/0005/555143/Power-of-Choice-Exempt-Areas.pdf](https://www.ergon.com.au/_data/assets/pdf_file/0005/555143/Power-of-Choice-Exempt-Areas.pdf)

- (b) The space provided for the *meter board* is inclusive of space required to meet clearance requirements for installation and access as required in this *manual* and:
  - (i) AS/NZS 3000 for *LV* connections; or
  - (ii) AS 2067 for *HV* connections.

## 9.6 Provision of access to *meter board*

- (a) The *Customer* shall provide safe and ready access to the *meter board* location, including the meters, main switch and MEN, so that meters and control equipment may be fixed, read, tested, adjusted, and removed without difficulty at any time.
- (b) The minimum access requirements for a meter enclosure shall be as per the requirements for switchboards as detailed in AS/NZS 3000.
- (c) The *meter board* location shall be located close to and be accessible by the road reserve as per the requirements of clause 9.8.
- (d) A *Customer* shall purchase and install a utility access lock where security of a *meter board* is necessary as per clause 9.7.

## 9.7 Provision of utility access locks

- (a) A *Proponent* may install a *meter board* in an area which may be locked:
  - (i) for security reasons; or
  - (ii) where the *metering installation* may be subject to vandalism.
- (b) Where a *meter board* is located in an area meeting the requirements of (a) the *Proponent* shall purchase and install utility access locks meeting the following requirements:
  - (i) Be an appropriate lock type as specified in drawing QCD09-01.<sup>19</sup>
  - (ii) Where on gate, installed to be accessible from outside the gate.
  - (iii) Key or security card boxes or dual locking bars are acceptable.
  - (iv) Except for arrangement described in (b)(iii), private locks shall not be installed for accessing *meter boards*.
  - (v) All tenants requiring access to the *meter board* will be provided with such access.
  - (vi) Meter locks shall not provide access to an enclosure which is identified as an unsuitable location in clause 9.8.1.2 or areas that require egress in a private area including on a garage door or verandah door.
- (c) If a *DNSP* is required to provide a tenant or owner access to the *meter board* in a locked area, a relevant fee or charge shall apply.
- (d) The *DNSP* may provide master utility access lock keys to *Metering Providers* when requested.
- (e) A *Metering Provider* shall keep master utility access lock keys provided secure and return them to the *DNSP* when no longer required or when requested by the *DNSP*.
- (f) For clarity this clause additionally applies to the meter panel and the CT chamber and board.

---

<sup>19</sup> Locks can be purchased through the contacts for utility access locks in Appendix A

## 9.8 Meter board location

### 9.8.1 General

#### 9.8.1.1 Location requirements

- (a) A *meter board* with *network devices* and metering equipment shall be installed in a location compliant with the following:
  - (i) AS/NZS 3000 for *LV* connections; or
  - (ii) AS/NZS 3000 & AS 2067 for *HV* connections.
- (b) All *network devices* and metering equipment for a *metering installation* shall be installed in one location on the ground floor in a single *meter board*. Multiple *meter board* locations may be permitted for multiple non-private *premises* and high-rise premises only, where they meet the criteria in clauses 9.8.3 and 9.8.4 respectively.
- (c) A *meter board* shall be readily accessible as per the requirements in clause 9.6.
- (d) A *meter board* shall be located at the side of a building facing a road reserve, on an outside wall, on the ground floor and at the front of the building or as otherwise specified in this *manual*.
- (e) To support electricity safety testing requirements for activities of the *DNISP* or *Metering Provider*:
  - (i) direct connect metering shall be installed in the same location as the main switch and *MEN* point; and
  - (ii) CT metering chamber shall be installed in the same location or within 5 meters, on the same floor, of the CT meter panel. There shall be no walls, doors or barriers preventing visual or physical access from the CT metering to the panel.
- (f) The requirements for *meter board* locations based on *premises* type shall be met as per Table 49.

**Table 49 Meter board location requirements for specific premises types**

<b>Premises type</b>	<b>Requirements</b>
<i>Domestic premises</i>	clause 9.8.2
<i>Non-domestic premises</i>	clause 9.8.3
<i>Community title</i>	clause 9.8.4

- (g) A *meter board* shall not be installed in any unsuitable locations as per clause 9.8.1.2.
- (h) A *meter board* shall be adequately protected against damage. Table 50 shows the minimum distance for locating a *meter board* from a driveway edge or trafficable area. If a *meter board* is installed in a location that encroaches on a driveway edge or trafficable area, suitable, permanent protective barriers shall be installed at the minimum distance specified in Table 51.

**Table 50 Minimum distance for locating a *meter board* from a driveway edge or trafficable area**

Property type	Minimum distance (mm)
Residential <sup>2</sup>	600
Other	1000

Note 1 – the minimum distance is measured from the face of the closed *meter board* in any direction.

Note 2 – multi-residential may require a minimum distance of 1000 mm where a large switchboard is installed.

- (i) *Meter board* requirements for multiple meter board locations, including unmetered submain arrangements, shall meet the requirements in clause 9.8.3 and 9.8.4.
- (j) Where changes to the *premises* including building, fencing, structural or landscaping works impact on compliance with this clause, the *meter board* shall be relocated to location compliant with the current version of the *QECM* at the time of the works.

## 9.8.1.2 Unsuitable locations

A *meter board* with *network devices* and metering equipment shall not be installed in any of the restricted locations for in clause 2.10.2.5 of AS/NZS 3000 or any of the unsuitable locations in Table 51.

**Table 51 Unsuitable locations for a *meter board* and associated equipment**

Category	Unsuitable locations for a <i>meter board</i> and associated equipment
(a) Pools or spas	<ul style="list-style-type: none"> <li>(i) Within or at any height above any pool or spa zone as defined in AS/NZS 3000.</li> <li>(ii) Any location where the only point of access is through the fenced area around a pool or spa.</li> </ul>
(b) Hazardous areas	<ul style="list-style-type: none"> <li>(i) Within any hazardous area defined in AS/NZS 3000.</li> <li>(ii) Within a gas emitting device (gas meter regulator) exclusion zone defined by AS/NZS 5601.1, AS/NZS 60079.10.1 and AS 4645.1.</li> <li>(iii) In particular, <i>Electrical Contractors</i> should be aware of the hazardous areas associated with exchange or in-situ fill LPG gas cylinders.</li> </ul>
(c) Egress areas	<p>In areas where egress may be impacted when accessing the <i>meter board</i>, including but not limited to:</p> <ul style="list-style-type: none"> <li>(i) Over stairways, ramps, fire isolated stairways.</li> <li>(ii) In narrow passageways.</li> <li>(iii) In rooms with toilets.</li> </ul>
(d) Trafficable areas	<p>In trafficable areas where the equipment or a person working on the equipment would not be adequately protected, including but not limited to:</p> <ul style="list-style-type: none"> <li>(i) In vehicle docks.</li> <li>(ii) Driveways.</li> <li>(iii) Factory walkways.</li> <li>(iv) Carports.</li> </ul>
(e) Adjoining property fences	<ul style="list-style-type: none"> <li>(i) On a side or shared boundary fence.</li> <li>(ii) In a position with less than 100 mm from the back of the <i>meter board</i> to a side or shared boundary fence.</li> </ul>
(f) Near machinery	In close proximity to machinery.

(g) Areas with unsatisfactory working conditions	Locations where personnel may be exposed to unsatisfactory work conditions including, but not limited to areas with exposure to: <ul style="list-style-type: none"> <li>(i) Fumes.</li> <li>(ii) Dust.</li> <li>(iii) Dampness.</li> <li>(iv) Noise levels exceeding LAeq.8h level of 85dB(A) as per the Qld Health and Safety Regulation and the Standard AS/NZS 1269.1.</li> </ul>
(h) Exposure to high temperatures	In positions where the ambient temperature exceeds 50 °C for example, boiler rooms.
(i) Low visibility	In areas with insufficient light.
(j) Confined spaces	In confined spaces.
(k) Restricted areas	<ul style="list-style-type: none"> <li>(i) In areas where the integrity of a security system will be affected by entry of the <i>DNISP or Metering Provider's</i> personnel.</li> <li>(ii) Where access is normally restricted for health or other reasons.</li> </ul>
(l) Multiple <i>electrical installations</i> <sup>1</sup>	Within a <i>premises</i> or single <i>electrical installation</i> of a multiple <i>premises</i> or similar, either <i>domestic</i> or <i>non-domestic</i> (shall only be located in a common area).
(m) Areas with inadequate access	In areas with inadequate access or areas that may be locked, including but not limited to: <ul style="list-style-type: none"> <li>(i) Behind a property perimeter fence other than located at the extremities of the property of boundary, unless on a rural property.</li> <li>(ii) Behind a property perimeter fence without an adjacent gate.</li> <li>(iii) Where this no direct route for access from the access gate to the meter board.</li> <li>(iv) In secured private areas.</li> <li>(v) In areas where the DNISP's staff require inductions to access the site where the site is permanent<sup>3</sup>.</li> <li>(vi) Where access may require any additional provisions e.g. EQP or scissor lift to perform a rescue of an injured worker<sup>4</sup>.</li> </ul>
(n) Enclosed verandahs	Within enclosed verandahs.
(o) Areas enclosing dogs	In areas enclosing dogs. A secondary fence rather than a perimeter fence shall be installed to separate a dog from a <i>meter board</i> (unless <i>meter board</i> located on perimeter fence <sup>2</sup> ).
(p) Areas with varying high intensity magnetic fields	In areas subject to varying high intensity magnetic fields. (Refer to <i>MIR</i> for current transformer meter panels in the vicinity of heavy current carrying conductors).
(q) On <i>DNISP</i> works	Installed on the <i>DNISP</i> works.

Note 1 – In alignment with clause 2.10.2.3 of AS/NZS 3000, for multiple *electrical installations*.

Note 2 – As per clause 9.10.3(c), a *meter board* may be installed on a perimeter fence.

Note 3 – This requirement does not apply to a *meter board* or temporary supply board in a building site requiring a temporary induction to access the site.

Note 4 – Additional consideration to providing adequate access for rescue purposes shall be undertaken when design and installation of a platform is required to access a *meter board*.

## 9.8.2 Meter board location requirements for *domestic premises*

For single or multiple *domestic premises*, a *meter board* shall be installed in a location compliant with clause 9.8.1.1 and the additional requirements in Table 52:

**Table 52** *Meter board location requirements for domestic premises*

<b>Domestic premises meter board location options</b>	<b>≤0.5 ha</b>	<b>&gt;0.5 ha</b>
(a) on the side of the main building of the <i>premises</i> facing a street from which there is a pedestrian access	Yes	Yes
(b) at the front property boundary facing road reserve recessed so that no part of the <i>electrical installation</i> is within road reserve	Yes	Yes
(c) within the first 2 m along an adjacent side of the main building of the <i>premises</i> to (a)	Yes	Yes
(d) where the main entrance to a <i>domestic premises</i> is on the side of a <i>premises</i> the meter board may be installed on the adjacent side of the <i>premises</i> to (a) no further than 1.5 m beyond the main entrance	Yes	Yes
(e) accessible by a motor vehicle	No	Yes

Note 1 – Representative diagrams of *domestic premises* meter board location options can be seen in drawings QCD09-02 and QCD09-03.

Note 2 – For alterations of *electrical installation* involving the *meter boards* see clause 4.9 and Appendix J for further information.

## 9.8.3 Meter board location requirements for *non-domestic premises*

For single or multiple *non-domestic premises*, a *meter board* shall be installed in a location compliant with clause 9.8.1.1 and the additional requirements in Table 53:

**Table 53** *Meter board location requirements for non-domestic premises*

<b>Specific premises type</b>	<b>Meter board location</b>
(a) Single <i>non-domestic premises</i>	(i) at a location exterior to any buildings or structures; and (ii) as near as practical to the <i>DNSP service point</i> .
(b) Multiple <i>non-domestic premises</i>	(i) at a location either: (A) exterior to any building or structure; or (B) within a switchroom; and (ii) as near as practical to the <i>DNSP service point</i> ; and (iii) in a readily accessible: (A) single <i>meter board</i> location; or (B) an additional <i>meter board</i> location may be provided for every 12 <i>Customers</i> with approval as per clause 4.8.

## 9.8.4 Meter board location requirements for community title premises

For *community title premises*, a *meter board* shall be installed in a location compliant with clause 9.8.1.1 and the additional requirements in Table 54 and drawing QCD09-04.

**Table 54 Meter board location for community title scheme**

<b>Community title scheme type<sup>1</sup></b>	<b>Meter board location</b>
(a) Dual occupancy <i>domestic premises</i> <sup>2</sup>	One <i>meter board</i> location on <i>common property</i>
(b) Multi-unit <i>domestic premises</i> in <i>building format plan</i> <sup>3</sup>	
(c) <i>Customer</i> reticulated	(i) <i>meter board</i> locations on <i>common property</i> (ii) additional <i>meter board</i> location may be provided for every 12 <i>Customers</i> with approval as per clause 4.8.
(d) <i>DNSP</i> reticulated to single occupancy <i>domestic premises</i> – via road reserve (not driveway) <sup>4</sup>	One <i>meter board</i> location per lot.
(e) Exclusive use area for each <i>premises</i> – via road reserve (not driveway)	One <i>meter board</i> location per lot in exclusive use area.
(f) Highrise <i>premises</i> ≥ 5 floors <sup>5</sup>	(i) <i>meter board</i> locations on <i>common property</i> (ii) up to one <i>meter board</i> on each floor

Note 1 – A *community title* developments meter board locations shall only select a single option of (a), (b), (c), (d), (e) or (f) from Table 54 for a development.

Note 2 – For example, duplexes..

Note 3 – see definitions, a *building format plan* is where a lot boundary is the floor, wall, or ceiling of the building.

Note 4 – Single *DNSP service point*, supplying a service to only one lot directly from road reserve and *DNSP* assets are within the boundaries of the lot and is not within a boundary structure (floor, wall or ceiling serving as lot boundary) for the lot.

Note 5 – A floor as defined under the Building Code of Australia.

Connection shall not be established or maintained to a *meter board* located in an area of *common property* that has been designated for the exclusive use of a lot if the *meter board* is multiple *Customers*. For example, fenced off and prohibiting access to other owners or occupiers to the *meter board* location, *DNSP service point* and *connection assets*. Appropriate access to *common property* shall be rectified to allow new or continued access to the *distribution system* to the *community title* scheme.

## 9.8.5 Multiple metering points

Where a connection meets the requirements for an additional *meter board* under clause 9.8 the following applies:

- (a) Allocation of *DNSP service points* to the *premises* shall meet the requirements of clause 5.2.
- (b) An unmetered submains may be used to connect the additional metering position from the main switchboard and first metering point.
- (c) Connections with multiple metering points shall meet the multiple *electrical installation* requirements in clause 5.6.

## 9.8.5.1 Unmetered submains

- (a) *Customers'* equipment, including devices that consume or measure electricity, shall not be connected to any unmetered conductor.
- (b) Where an unmetered submains is used to connect an additional metering position:
  - (i) a lockable circuit breaker shall be provided at the origin of the unmetered submains;
  - (ii) voltage drop on unmetered submains shall not exceed 2.5% of the supply voltage.
- (c) The use of unmetered submains for an installation shall require submission of the details of proposed meter positions, unmetered submains, their circuit protective devices and voltage drop calculations for approval as part of a connection application.

## 9.9 Meter board enclosure requirements

### 9.9.1 Asbestos safety warning

SAFETY WARNING - ASBESTOS
<ul style="list-style-type: none"><li>• The meter and switchboard panels in older type <i>meter boards</i> may contain asbestos.</li><li>• Electrical workers who are required to work on these meter panels need to identify if this hazard is present and, if necessary, take appropriate action.</li><li>• Old Zelemite (black) electrical switchboards can contain up to 20% asbestos. When working on an electrical switchboard that was manufactured prior to 1987, assume the presence of asbestos, even if it is not marked as such.</li><li>• Asbestos information including codes of practice and legislative requirements is available on Queensland Government's <a href="http://www.asbestos.qld.gov.au">www.asbestos.qld.gov.au</a> website.</li></ul>

Figure 4 Safety Warning – Asbestos in *meter board* enclosures and meter panels

### 9.9.2 Meter board enclosure on property pole

- (a) Where a *meter board* enclosure is erected on a property pole the enclosure shall:
  - (i) meet the requirements of Appendix H;
  - (ii) be adequately fixed in position; and
  - (iii) be suitably treated against corrosion.

## 9.10 Meter board enclosure installation

### 9.10.1 General

*Meter board* enclosures shall be labelled in compliance with clause 8.2.

### 9.10.2 Mechanical protection of meters board enclosures

- (a) Meters, *network devices*, associated equipment and their enclosures shall be protected from mechanical damage, by either their location or the manner of mounting.

- (b) Meters shall be enclosed in a suitable meter enclosure where they are erected in a position exposed to environmental impacts that may cause mechanical damage such as the effects of weather, direct sunlight, corrosive atmospheres.
- (c) Meter reading windows in meter enclosures are not permitted.
- (d) Where a meter enclosure is installed on a temporary structure, the supporting structure shall be mechanically sound. Where the temporary structure is used for building purposes it shall comply with the requirements of AS/NZS 3012<sup>20</sup>.

### 9.10.3 Mounting *meter board* enclosures

- (a) Adequate clearances shall be provided around *meter board* enclosures including doors in open positions as per AS/NZS 3000. When mounting the *meter board* enclosure, the *Proponent* shall consider any structures, doors, landscaping or fixtures planned for construction after initial connection that may impact clearances of *meter boards* to prevent the requirement for future rectification works under clause 4.3.2.1 (b).
- (b) Where meters and *network devices* are accessible only from the outside of a building, they shall be enclosed in a suitable meter enclosure mounted on or recessed into the outside wall of the building.
- (c) *Meter board* enclosures mounted on the front boundary may open towards the footpath. It is recommended that meter enclosures mounted in these positions be locked with utility locks meeting the requirements of clause 9.7.
- (d) Other than where the requirements of (b) are satisfied, *meter board* enclosures shall not be installed where they protrude or open across a property boundary.

### 9.10.4 CT metering housing

- (a) Each set of CTs and meter voltage fuses shall be mounted in a separate dedicated metering chamber which encloses only the *Metering Provider's* equipment.
- (b) To allow safe performance of commissioning and testing of CT *metering installations*, all live LV parts within CT chambers shall be individually insulated. To ensure adequate insulation refer to the following:
  - (i) insulation shall completely cover all live parts in the CT chamber; and
  - (ii) heat shrink insulation is acceptable for insulating busbars; and
  - (iii) all bolted busbar or cable connections are to be covered with non-adhesive insulation secured in place by cable ties; and
  - (iv) a non-conductive insulated barrier alone, such as a removable cover over a CT chamber, is not an acceptable method of insulation.

### 9.10.5 *Meter board* enclosure earthing

- (a) All metallic *meter board* enclosures shall be earthed. Where double insulation is maintained throughout the *meter board* enclosure, in accordance with the requirements of AS/NZS 3000, earthing is not required.
- (b) The *metering installation* in the metering board enclosure shall meet the earthing requirements of clause 8.8.

---

<sup>20</sup> This may include the connection of permanent supply for domestic building purposes in a URD estate.

## 9.10.6 Platform requirements

- (a) Where a *Proponent* is required to provide a platform<sup>21</sup> to access a *meter installation*:
  - (i) the platform shall be designed and constructed to AS 1657; and
  - (ii) the platform shall be designed to support a minimum load of 200kg; and
  - (iii) the platform shall be certified by a *RPEQ* that the structure is suitable for the application; and
  - (iv) a certificate of approval shall be submitted to the *DNSP* for approval under clause 4.8 prior to connection of supply.
- (b) Where metering, *network devices* and *meter board* enclosures are installed on property poles, the platform shall be self-supporting and permanently mounted.
- (c) The property pole shall not be used to support any platform structure, and any step-type ladder access shall be clear of any fences or sharp objects that may be considered a fall hazard.
- (d) For existing installations where access is considered unsafe, the *Metering Provider* may refuse to read the meters until the unsafe condition has been rectified by the *Customer* or may repair the access at the *Customer's* cost as per the Queensland Electricity Regulation 2006 (Qld).

## 9.11 Approval of metering and electrical installation designs

### 9.11.1 General

The *DNSP* may require metering and electrical *installation* designs for approval:

- (a) to meet safety obligations under the *energy laws* as described in clause 4.6; or
- (b) to make a connection offer or maintain a connection agreement under the requirements of the *NER*.

### 9.11.2 LV CT metering drawings

- (a) The *Proponent* shall have approved *LV CT metering installation* designs from the *DNSP* as per clause 4.8 prior to arranging connection of supply.
- (b) The *DNSP* requires all *LV CT metering installation* designs to have prior approval as per clause 4.8 for the metering arrangement by submitting the *DNSP LV CT Advice Form*<sup>22</sup> with:
  - (i) switchboard layout diagrams; and
  - (ii) single line diagrams; and
  - (iii) sufficient time allocated to cater for design modifications to be carried out if necessary, prior to switchboards being built.
- (c) Early submission of drawings will assist in reducing the impacts for all parties and avoid modifications of constructed CT metering switchboards. Where information supplied to the *DNSP* is insufficient or has not been supplied with adequate time to cater for review and potential modifications, the *DNSP* cannot guarantee supply will be connected to the metering switchboard as per requirements under clause 9.11.

---

<sup>21</sup> A platform shall be constructed from levelled, flat, compacted soil. Loose, mounded or ramped soil is not acceptable as access for a *metering installation* or a *meter board* enclosure.

<sup>22</sup> Energex: <https://www.energex.com.au/about-us/contact-us/forms/general-forms/lv-ct-metering-advice-form>, Ergon Energy Network: <https://www.ergon.com.au/network/contractors-and-industry/electrical-contractors/forms.-manuals-and-standards/lv-ct-metering-advice-form>

# Queensland Electricity Connection Manual



Part of Energy Queensland

## 9.11.3 HV metering and *electrical installation*

The requirements for *HV* metering and associated *electrical installation* drawing review are as per clauses 11.3 and 11.4.

## 10 LV connected *network device* and metering requirements

### 10.1 Metering isolation and connection devices

#### 10.1.1 General requirements

- (a) To facilitate the requirements of the *energy laws*, the supply to the revenue metering equipment for each *Proponent* must be capable of being individually isolated in order to perform electrical work.
- (b) A metering isolation device shall be capable of isolating the metering to allow safe access to the metering equipment. To achieve suitable isolation, the metering isolation device shall be installed within the *meter board* enclosure, connected between the *DNSP* service point and the metering.
- (c) The metering isolation device shall be either:
  - (i) a metering isolation link (*MIL*); or
  - (ii) a circuit breaker; or
  - (iii) isolator.
- (d) All new direct connected metering and CT *metering installations* shall install a metering isolation device and shall be connected in the same line to load sequence.
- (e) For requirements regarding *metering installations* being altered refer to clause 4.3.
- (f) Refer to clause 10.2.2.1 for existing installations requirements. The requirement to install meter isolation device applies to all new installations including direct connected metering and current transformer metering.
- (g) for *meter boards* with multiple individually metered *electrical installations* as per clause 9.8.3 and 9.8.4, a metering isolation device shall be provided for each *network device* and installed adjacent to the relevant metering equipment; and
- (h) for *Proponents* with three-phase supply, the metering isolation devices are to be grouped together and if not obvious, labelled in accordance with clause 8.2.3 to indicate the meter(s) *electrical installation* that they control.

#### 10.1.2 Metering Isolation Link (MIL) requirements

- (a) In addition to the requirements in 10.1.1, a *MIL* shall meet the following installation requirements:
  - (i) *MILs* are to be installed on the line side of all direct connected metering equipment; and
  - (ii) the *MIL* shall be mounted horizontally or vertically on the front of the metering panel and if not obvious, labelled in accordance with clause 8.2.3 to indicate the meter and portion of the *electrical installation* that they control; and
  - (iii) clearance around the ends of *MIL* shall be 40 mm; and
  - (iv) where a fuse is used to replace the solid link (Refer to Section 10.2.2.1) the maximum load through the *MIL* shall not exceed the rating of the fuse.
- (b) Aluminium cables are not suitable for connection directly into *MIL* terminals unless fitted with a suitable means of termination, such as a soft-form bi-metallic sleeve or ferrule that is compatible with the *MIL* terminal metal. Where Aluminium cables are used as *consumer mains*, they shall comply with the requirements of the electrical component manufacturers, cable manufacturers and AS/NZS 3000, particularly in respect of termination and bending.
  - (i) The load through a *MIL* shall not exceed 125A. In multiple tariff supply applications, for example a primary and secondary tariff, where the load exceeds 125A, additional metering isolation devices shall be required.
  - (j) *MILs* shall meet the following requirements:

- (i) comply with drawing QCD10-01;
- (ii) be clear cased type that comply with IEC 60269.1; and
- (iii) sealable; and
- (iv) back wired; and
- (v) fitted with a tubular link.

## 10.1.3 Circuit Breaker (CB) requirements

- (a) For *electrical installations* that meet the requirements of 10.2.1(b) and require a *CB* for the metering isolation device for a direct connect meter, the D curve *CB* is to be installed within the *meter board* enclosure, connected between the *DNSP* service point and the metering as per clauses 10.1.1. and 10.2.1(b) and the following shall apply:
  - (i) The *CB* is to be installed on the front of the meter panel in place of the *MIL*; and
  - (ii) where metering isolation *CBs* are used in a three-phase installation, all three phases must have *CBs*. If individual *CBs* are installed the requirements of clause 10.1.1 must be met; and
  - (iii) the *CB* is required to be enclosed in a sealable non-metallic enclosure with a clear cover to allow the *Proponent* to determine if the circuit breaker is in the open or closed position without removing the cover. Enclosures that are lockable only are not acceptable; and
  - (iv) if the marking on the *CB* is not legible when the cover is in place, the open and closed positions are to be identified by additional marking on the enclosure; and
  - (v) a permanent indelible label as per Figure 5 shall be fixed on or adjacent to the circuit breaker enclosure.

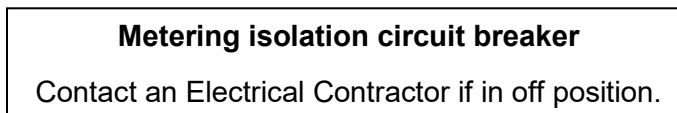

Figure 5: Meter isolating device *CB* label

## 10.1.4 Isolator requirements

An isolator shall be installed in accordance with the general requirements of clause 10.1.1.

## 10.1.5 Metering active and Meter Neutral links

- (a) Metering active and metering neutral links shall be mounted on the rear of the meter panel or meter enclosure. Where metering active and neutral links are mounted on the rear of the meter panel, they shall be mounted in such a way that they do not interfere with the mounting of the metering equipment.
- (b) To not interfere with metering equipment (normally mounted on the upper or middle section of the meter panel) it is preferable for the metering active and neutral links to be mounted as close as practical to the bottom of the meter panel.
- (c) Where metering active and neutral links are mounted on the rear of the meter enclosure and the material on which they are mounted is conductive, they shall be mounted on insulating material with low water absorption properties that will extend past the live parts of the link by a minimum of 25mm in all directions. This mounting arrangement is not required where the link has been specifically designed and type tested for installation onto metal surfaces.
- (d) Access to metering links must not be obstructed by any structure or wiring within the switchboard.

- (e) Incorporate a separate connecting device for the incoming and each outgoing circuit; and
- (f) consist of tunnel terminals for termination of the conductors using one of the following methods (i); (ii) or (iii) for termination of the conductors:
  - (i) provide two screws for each terminal; or
  - (ii) provide one screw, the outside diameter of which is not less than 80% of the tunnel diameter; or
  - (iii) provide one screw, which is arranged so that the conductor is clamped by suitable ferrules or plates in direct contact with the conductor; and
- (g) Be sealable or where this facility does not exist, such as for larger sized *consumer mains*, install links within a suitable dedicated enclosure, fitted with a sealable cover.

## 10.1.5.1 Metering Active Links

- (a) Where *consumer mains* are installed for the purpose of supplying more than one *Customer*, a set of metering active links shall be used between the building isolator and the direct connect meters.
- (b) Metering active links may be required to facilitate the ease of connecting large cables to MILs in multiple *domestic* or *non-domestic premises* installations or when there are more than two meters connected to a single-phase *electrical installation*.

## 10.1.5.2 Metering neutral links

- (a) The metering neutral shall be connected to a dedicated terminal of a metering neutral link.
- (b) All meter and *network device* neutral terminals shall be connected to a dedicated terminal of the metering neutral link via a separate neutral conductor.
- (c) There shall not be any soldered connections to the meter and *network device* neutral.

## 10.2 Isolation of direct connected metering

### 10.2.1 Single installations

- (a) For *electrical installations* with direct connect metering, with the exception of *electrical installations* considered in (b), a *MIL* per phase shall be installed within the *meter board* enclosure, connected between the *DNSP service point* and the metering as per clause 10.1.2.
- (b) For *electrical installations* with direct connect metering where overload protection for the *consumer mains*, in accordance with AS/NZS 3000, cannot be achieved by the positioning of the installation's circuit breaker main switches on the load side of the metering the following shall apply:
  - (i) a metering isolation D curve *CB* sized for overload protection of the *consumer mains* is to be installed within the *meter board* enclosure, connected between the *DNSP* service point and the metering as per clause 10.1.1; and
  - (ii) the *CB* is to be installed as per the requirements of clause 10.1.3;
  - (iii) the *CB* is required to meet the rating limitations as per the *MIR*.
- (c) The *DNSP's* service fuse shall not be considered as overload protection as per clause 8.7.1(b).

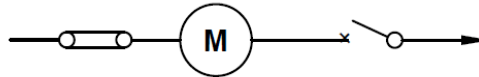

Figure 6: Typical DC Metering Arrangements

## 10.2.2 Multiple *domestic* or *non-domestic* premises

- (a) For *premises* with multiple *domestic* or *non-domestic* premises that are individually metered *electrical installations* the following shall apply:
- (i) A lockable load-break isolator, known as a building isolator, with facility for locking off, capable of isolating supply to the entire *electrical installation* shall be installed for all multiple *domestic* or *non-domestic* premises *electrical installations*, including multiple *Proponents* supplied electricity from remote metering points as per clause 9.8.
  - (ii) Where a *CB* main switch is installed for overload protection of the *consumer mains* in accordance with AS/NZS 3000, it shall be lockable, connected on the line side of the metering and can be used in place of the building isolator. Refer to Drawings QCD10-03 and QCD10-04.
- (b) In addition to the requirements in (a) *Proponents* shall have MILs for individual metering for *electrical installations*. For more information refer to clause 10.1.2.

## 10.2.3 Non-standard legacy direct connected metering installations

Where making alterations to a *metering installation* with direct connect metering under the requirements of clause 4.3.2, the following applies in concern to existing *metering installations* that were compliant at the time of installation but no longer meet the requirements of this *manual*:

- (a) All meters at the one-meter location shall follow the same sequence, that is, be either all connected before, or all connected after the main switch(s) or any lockable isolator.
- (b) Where direct connected meters are installed to facilitate a *Proponent* requested tariff change, additional tariffs, or installation of a *small IES* on an existing single *domestic* or *non-domestic* premises installation, the meters shall be connected between the *DNSP service point* and the *electrical installation's* switchgear with MILs installed in accordance with clause 10.2.1(a).
- (c) For multiple *premises* installations where an individual *premises* main switch is connected on the *DNSP service point* side of the meters, addition of a new meter shall be connected on the *DNSP service point* side of the individual *premises* main switch. A means of isolation in accordance with clause 10.2.1 shall be provided to allow isolation of the meter without interrupting supply to other *Proponents*. Where *Proponent* works are major alterations as per clause 4.3.2 a means of isolation in accordance with clause 10.2.2 shall be provided.
- (d) For alterations to connected *premises* with multiple single-phase *premises* utilising plug-in meters, the need to install MILs as per (c) is not required where an approved plug-in meter is being used for the replacement. This clause is inclusive of single-phase *premises* with a *small IES* or a tenancy with Time of Use metering (TOU).
- (e) Where the *DNSP's* service fuse is greater than 80 A, protective fault current limiting devices shall be supplied and installed by the *Proponent*.
- (f) For multiple *domestic* or *non-domestic* premises direct connected *metering installations*, where the service fuse protection is greater than 80 A, a *Metering Provider* shall install an 80A fuse in the *MIL* in place of the solid link.

- (g) Where fuses are installed, the *Metering Provider* will provide the fuse and fix a permanent indelible label as per Figure 7 on the *meter board* panel adjacent to the metering isolation links.

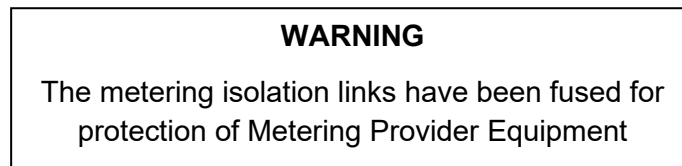

**Figure 7: Meter isolating link fuse warning label**

- (h) Where the *Metering Provider* determines that the meter requires an 80 A fuse for adequate overload fault protection, the *Metering Provider* can install an 80 A fuse in the metering isolation link provided the maximum demand of the installation does not exceed 80 A. Should a 100 A supply be required, the *Metering Provider* shall ensure the meter used is suitably rated for, and protected by, the 80 A service fuse. By complying with this clause, a *Proponent* shall not create conflict with clauses (e), (f) and (g) above.

## 10.3 Isolation of CT metering

### 10.3.1 General

- (a) CT metering shall be capable of being individually isolated by a suitable isolator located within the *meter board* enclosure, connected between the *DNSP* service point and the CTs.
- (b) CT metering isolation shall be a lockable load-break isolator, with facility for locking on and off.
- (c) CT metering shall comply with the drawings QCD10-03 and QCD10-04 as relevant.
- (d) In addition to isolation for CT metering the *electrical installation* shall have a main switch for isolation for the *electrical installation* installed in compliance with clause 8.7.3.1 on the load side of the CTs.
- (e) All isolation equipment shall be clearly identified and readily accessible.
- (f) CT metering shall be installed and maintained by the *Proponent*.
- (g) The meter isolator shall not be used for automatic interlocking or automatic transfer functions.
- (h) Where directed connected metering is installed at the same switchboard as the CT metering, the direct connected metering is to comply with clause 10.2.2.

### 10.3.2 For multiple *domestic or non-domestic premises*

- (a) For *premises* with multiple *domestic or non-domestic premises* that have multiple *metering installations*, the entire installation shall have a single isolator known as a building isolator. The building isolator shall be a lockable load-break isolator, with facility for locking off and capable of isolating supply to the entire *electrical installation*.
- (b) Where the *DNSP* is required to isolate supply to the building isolator, for installations with multiple premises there may be charges made as per clauses 4.1.4.
- (c) For individually metered premises within a *premises* with multiple metered *electrical installations* a lockable load-break isolator, with facility for locking off, shall be installed between the building isolator and the metering CTs on the same switchboard as the CTs. The individual *electrical installation* will also have a main switch(s) installed on the load side of the metering CTs located on the same switchboard as the CTs. Refer to drawings QCD10-03 and QCD10-04.

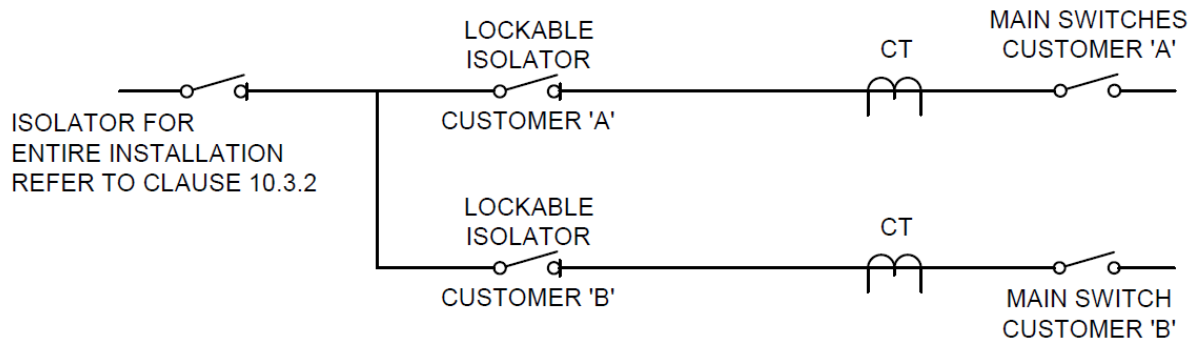

**Figure 8: Typical CT Metering Arrangement for Multiple Customer**

### 10.3.3 Non-standard legacy CT metering installations

For legacy or existing *electrical installations* where the meter isolator and the main switch are the same switch, the meter isolator shall not be used for automatic interlocking or automatic transfer functions.

## 10.4 Non-standard metering arrangements

### 10.4.1 Card Operated Metering

In designated remote communities, within the Ergon Energy *Distribution Network*, card operated meters will be supplied to *Customers*. Where card operated meters are supplied the following requirements shall be met:

- (a) A MIL is required to be installed on the line side of the card operated meters as per clause 10.1.1 and 10.2.1
- (b) A single *meter board* location shall be located on common ground for each *premises* as per clause 9.8
- (c) Where a single *meter board* location is not possible an approval will be required as per clause 4.8
- (d) Please refer to Appendix M for a list of areas for card operated meters.

## 10.5 Metering neutral requirements

### 10.5.1 Connection of metering neutral conductors

- (a) The neutral conductor of the *consumer mains* shall not to be joined or looped through the terminals of a meter or metering neutral link.
- (b) Metering neutral conductors shall not be looped between metering equipment.
- (c) When alterations or additions are required on existing installations with neutral looping, as per clause 4.3.2, the looping must be removed and the metering neutral link installed.
- (d) The metering neutral shall be connected to the main neutral in such a manner that it cannot be disconnected or removed, for instance:
  - (i) soldered or crimped to the main neutral;
  - (ii) a flag lug under the main neutral connection, slotted lugs shall not be used;
  - (iii) a sealable terminal or bolt on the neutral link/bar where:
    - (A) the *consumer mains* are a busway or busbar arrangement;
    - (B) the installation main switchboard is supplied by more than one *DNSP service point* and a bus-tie arrangement is in place in compliance with clause 5.6.2. The *consumer mains* neutrals shall be connected to a common neutral link/bar;

- (iv) where the main neutral conductor is 25 mm<sup>2</sup> or larger a sealable terminal may be used;
- (v) under a stud fitted with a suitable nut that is drilled and tapped into the *consumer mains* neutral lug, provided the arrangement can be sealed.
- (vi) in domestic premises installations where parallel *consumer mains* are used the metering neutral conductor shall be soldered to one conductor only.

## 10.5.2 Accessibility of neutral conductors

- (a) The metering neutral connection is to be readily accessible and shall not be located behind a panel where access requires isolation of supply.
- (b) On heavy current switchboards (refer to AS/NZS 3000) the main neutral and *MEN* connections to the busbar shall be located in an accessible position with a minimum of 600 mm clearance from exposed live parts. If a minimum clearance of 600 mm cannot be achieved, the use of a permanent barrier or location within a chamber separate from that of the main switch or other exposed live parts is acceptable.
- (c) The arrangement must allow the main neutral and *MEN* connections to be safely accessed without isolating the supply to the switchboard or moving other cables (refer to AS/NZS 3000).

The use of shrouds over cable connections is not a sufficient barrier as the shrouds need to be removed during polarity testing (unless access to conductors is provided via test probe holes without the need to remove the shrouds).

## 10.6 LV network device and metering requirements

### 10.6.1 Spacing requirements

- (a) Minimum meter and *network device* space requirements for *LV* direct current meters board enclosures and panels are specified in H.2 of Appendix H.
- (b) Minimum space requirements for *meter board* enclosures and panels for *LV* CT metering are specified in the *MIR*.
- (c) All metering enclosures shall include provision of space for installation of an antenna/aerial.
- (d) Minimum space requirements for mounting of meters and *network device* are shown in Table 55.

**Table 55 Meter and *network device* equipment spacing requirements**

Meter and <i>network device</i> details	Height (mm)	Width (mm)	Depth (mm)	Approx. weight (kg)
<i>Network device</i>	190	110	110	0.5
Metering Isolation Link ( <i>MIL</i> )	90	45		

- (e) Other than the requirements of clause 10.1.2 (a) (ii), the minimum clearance between any item of metering or control equipment shall be 25 mm.

### 10.6.2 Mounting metering and *network device* equipment

#### 10.6.2.1 Mounting arrangement

- (a) All meters, *network devices* and *MILs* shall be mounted on a side hinged panel such that the metering and *network device* remain in the vertical plane at all times.

- (b) Meters and *network devices* shall be mounted vertically with cable connections at the bottom of the equipment.

## 10.6.2.2 *Meter board panel fixings*

- (a) *Meter board* panels shall be constructed of a durable, non-conducting, fire resistant material with low water absorption properties and shall not contain asbestos.
- (b) Alterations requiring a replacement meter panel shall comply with (a). See clause 4.3.2 for information about classification of alterations.
- (c) Meter panels in good condition that do not contain asbestos and are not classified as an alteration under (b), shall not require replacement where they satisfy the following requirements:
  - (i) Where existing panels have not been constructed with fire-resistant material, all new and retrofitted electronic equipment associated with metering and network devices on the existing panels are installed behind an asbestos-free insulated fire-retardant backing boards with low water absorption properties;
  - (ii) Where existing panels are constructed with fire-resistant material equipment and is installed in compliance with this *manual*.
- (d) Bolts or screws used to mount and fix equipment on insulated *meter board* panels shall be fit for purpose. Where mounting bolts or screws protrude through the *meter board* panel and can be contacted, a non-conducting bolt or screw (e.g., nylon or plastic) shall be used.<sup>23</sup>
- (e) The *meter board* panel within the *meter board* enclosure should be not more than 300 mm from the front of the *meter board* enclosure.
- (f) The *Customer* owned main switch shall be located in the *meter board* and may be located on DIN rail on the *meter board* panel.
- (g) The *Customer* metering active link, metering neutral link and *MEN* shall be mounted on the rear of the meter panel or meter enclosure and shall not be mounted on the front of the meter panel.
- (h) The *meter board* panel is dedicated for metering equipment and *network devices*. *Customer* owned equipment, including but not limited to General Power Outlets (GPOs) and contactors, shall not be installed on the *meter board* panel.
- (i) Where a larger *meter board* panel is used, it is permissible for *Customer* owned equipment to be installed on the same panel outside of an area dedicated for use for metering equipment provided the meter panel area meets the minimum size specified in Appendix H, is indelibly marked with a demarcation line and is labelled to indicate the meter panel section is dedicated for metering and *network devices*.
- (j) *Meter board* panels on BTS as per clause 6.9, do not need to be dedicated to metering equipment unless they are intended to be installed in the permanent position.

## 10.6.3 *Proponent obligations to provide access for network device*

- (a) Where a *Proponent* applies to connect a *metering installation* with a controlled tariff the *Proponent* shall make provision for a separate *network device* as per clause 9.2 in the *meter board* by predrilling the *meter board* panel for cable access to fit the *network device* as per drawing QCD10-02.

---

<sup>23</sup> Metal screws with needle points and self-drilling tips are not permitted. The insulating of metal screws using silicone or other material is not permitted.

- (b) The *network device* will only be installed when the *Proponent* has requested controlled tariff as part of the *EWR* for the *electrical installation*.
- (c) Refer to clause 9.2 for more information on *network devices* and Appendix I for more information on controlled tariff eligibility.

## 10.6.4 *Proponent* obligations to provide wiring for metering and *network devices*

- (a) The *Proponent's Electrical Contractor* shall install all *network device* wiring.
- (b) The *Proponent's Electrical Contractor* shall install all meter wiring unless otherwise agreed with the *Metering Provider*. Refer to clause 9.2.

### 10.6.4.1 Size of *network device* wiring

- (a) The wiring from a *controlled supply* meter to a *network device* or *controlled load* main switch and all meter neutral wiring shall be PVC insulated stranded copper cable of no more than 7 strands, a minimum of 4mm<sup>2</sup> and shall not exceed 6mm<sup>2</sup>.
- (b) Aluminium cables are not permitted for connection directly into *network device* terminals.

## 10.6.5 *Network device* requirements

- (a) All meter and *network device* terminals shall be connected directly to *MIL* or Metering Active Link for direct connected installations.
- (b) Where *controlled loads* are required, provision for a separate *network device* shall be made.
- (c) The *network device* will only be installed when the *Proponent* has requested *controlled load* as part of the *EWR* for the installation.
- (d) The drilling for the *network device* shall be completed by the *Proponent's* electrical contractor as per clause 10.4.3.
- (e) Two and three switch *network devices* will be utilised for the following situations:
  - (i) For single installations where a combination of water heating and other *controlled loads* are connected. See Appendix A for connection information.
  - (ii) For multiple *domestic premises*, such as flats and home units. See Appendix A for connection information.
- (f) Equipment connected to a *controlled supply* is to be permanently connected. However, there is specific equipment that may be connected via a socket outlet. See Appendix I for details on controlled tariffs and equipment requirements.
- (g) Where a socket outlet is provided for specific controlled equipment, it shall be dedicated to the *controlled supply* equipment as spare *controlled supply* outlets are not permitted.
- (h) A permanent indelible label shall be fixed on or adjacent to the controlled socket outlet stating the following:

Figure 9: *Controlled supply* meter label for dedicated GPO

Controlled Supply Only

### 10.6.5.1 *Network device* connections

- (a) Where equipment other than water heating, is to be connected to a *controlled supply*, this equipment is to be connected via a dedicated circuit and connected to a dedicated switch in a multi-switch *network device*.
- (b) For existing installations where submains are installed from the *meter board* to a distribution board, other equipment can be connected to the *controlled supply*. Any other equipment connected to the *controlled supply* will be switched at the same time as the hot water supply. This shall only be permitted provided the *meter board* and the distribution board are not located within a 20 metre proximity or back-to-back with each other.

## 10.6.5.2 Single-phase *network device* connections

Single-phase installations with *controlled supplies* shall be connected in accordance with drawings QCD10-05 and QCD10-11.

## 10.6.5.3 Multiple-phase *network device* connections

- (a) Multiple installations where multi-switch *network devices* are utilised must be provided with a *network device* switch per premises in accordance with drawing QCD10-07 and QCD10-08. Switching of the hot water to an individual premises using contactors is not permitted.
- (b) Connections to multi-switch *network devices* shall be clearly labelled to identify the switch applicable to each premises.
- (c) A separate *MIL* is to be used for supply to the *network device(s)*. Where more than one switch per *Customer* is required then an individual *network device* per *Customer* shall be used as per clause 10.5.5.2.
- (d) Polyphase installations with direct connected meters shall be connected in accordance with drawings QCD10-09 and QCD10-10.
- (e) Three-phase loads, such as motors, shall be controlled via a *network device* switching a contactor as per drawing QCD10-10.

## 10.6.5.4 Contactor for control of non-continuous load

- (a) A contactor is required where the single-phase load to be controlled exceeds:
  - (i) 40 A resistive e.g., electric water heaters, electric vehicles; or
  - (ii) 20 A inductive e.g., motors, pumps; or
  - (iii) 20A for a single device that is a combination of resistive and inductive load, e.g., air conditioners or there are multiple devices on the circuit that together are a combination of resistive and inductive loads.
- (b) Where required, a contactor shall be:
  - (i) supplied by the *Proponent*; and
  - (ii) be of a type acceptable to the *DNISP*; and
  - (iii) be installed in an accessible position within the main switchboard; and
  - (iv) if required, in a sealable fit for purpose enclosure; and
  - (v) comply with drawings QCD10-10, QCD10-12 and QCD10-13.
- (c) In the *Energex distribution network* area, an additional switch of a multi switch *network device* may be used in place of a contactor in *domestic premises electrical installations* provided the load on each switch complies with that given above. Paralleling of switches is not permitted.
- (d) Contactors with no external moving parts are suitable for use without further protection and do not require provision for sealing.
- (e) Three-phase *electrical installations* requiring a contactor shall have the *network device* connected in accordance with drawing QCD10-10 for direct connected meters and drawing QCD10-12 and QCD10-13 for CT metering.
- (f) The contactor shall not be used for automatic load control, that is it shall not have a humidistat, a flow switch, a thermostat, a pressure switch, or the like connected in its control circuit.

## 10.6.5.5 AFLC frequencies

*Proponents* shall design and operate *electrical installations* which do not interfere with frequencies in Table 56 used by the *DNISPs* for Audio Frequency Load Control (*AFLC*).

**Table 56 DNSP audio-frequency signals for load control**

Region	Frequency (nominal) Hz
North Queensland	217
Capricornia	225
Far North, Mackay and Wide Bay	317
South West	425
South East	1042

## 10.7 EG system metering

### 10.7.1 EG metering schemes available

- (a) Two metering schemes are available for the grid-connected *embedded generating (EG)* systems, known as the “Net Energy” and the “Gross Energy” schemes. All *EG* systems installations shall be compliant with the *DNSP*’s connection standards.
- (b) The Queensland Government Solar Bonus Scheme or Regional Feed-in Tariff requires the installation of a Net Energy metering solution.
- (c) The Net Energy metering scheme has a single *import/export* meter installed in the place of the existing general supply energy consumption meter(s).
- (d) The Gross Energy metering scheme may require an additional *import/ export* meter installed on the meter panel to record the *EG* system supply energy generation only.

### 10.7.2 Solar bonus schemes and Power Purchase Agreements

- (a) *Proponents* wishing to be compensated for any electricity *exported* by the *EG* system to the distributor’s supply network other than through the Queensland Government Solar Bonus Scheme must also have a Power Purchase Agreement in place with their *Retailer*.
- (b) Details on how feed-in tariffs works and determining eligibility for the retention of Queensland Government Solar Bonus Scheme can be found at the Queensland Government website <https://www.qld.gov.au/housing/buying-owning-home/feed-in-tariffs>

### 10.7.3 Approval of equipment

- (a) Typical direct connected metering arrangements have been developed in line with *EG system* requirements and *Retailer* offered supply types however it is up to the *Metering Provider* to install suitable metering arrangement to meet site requirements.
- (b) Approval may be provided for a different metering arrangement in (a). Written application shall be provided to the *DNSP* and is subject to review and acceptance. Standard charges will apply for such arrangements.
- (c) It must be noted that the “Gross Scheme” may require an additional meter and the end user must be made aware that provision of this space is required at the current metering location.
- (d) In a “Net Scheme”, if the principal metering has more than one phase, it is a requirement that a polyphase meter must be used.

## 11 HV connected metering requirements

### 11.1 General requirements

- (a) All HV equipment shall be compatible with the DNSP's supply. Relays, current transformers and other protective equipment shall have characteristics compatible with the DNSP's existing protective system.
- (b) The design, construction and installation of all HV equipment shall comply with the appropriate Australian Standards e.g., AS/NZS 3000, AS 2067 or other equivalent Standards such as IEC Standards. Plans, drawings and relevant details describing the proposed installation and its operating conditions shall be provided.
- (c) The DNSP will advise the *Proponent* of the prospective fault level and the normal fluctuations of supply voltage for which provisions should be made.
- (d) The process to establish an initial HV connection, is detailed in Appendix K- Stakeholder interactive diagrams for connection participants.
- (e) The metering requirements in Section 9 also apply to HV installations. Where there are differences between the information in Section 9 and Section 11 or the remainder of the QECM, the requirements of Section 11 prevail in relation to HV metering. The additional details contained in Section 11 are specific to HV metering installations. The DNSP or Metering Provider can be contacted for additional information.

### 11.2 DNSP metering requirements review

- (a) The arrangement for the HV metering installation will be determined during the connection enquiry and application process.
- (b) The DNSP shall be contacted by the *Proponent* during the early stages of the design of the HV metering installation. The DNSP may require the *Proponent's* HV metering installation to have any or all the following requirements:
  - (i) Specialised metering design e.g., voltage change-over schemes etc.
  - (ii) Compliance with the NER.
  - (iii) Equipment with long lead times e.g., 6 to 12 months' notice required.
  - (iv) Full or partial check metering requirements for large loads.
  - (v) Generator connections and import/export load flows.
  - (vi) Test certificates for metering instrument transformers from an accredited laboratory.
- (c) The *Proponent* shall provide to the DNSP prior to connection, metering installation designs that are approved by a Metering Provider or Metering Coordinator. The *Proponent* shall supply a single line diagram, HV switchboard layout and a schematic diagram showing the wiring details from the instrument transformers (current and voltage transformers) to the metering panel.

### 11.3 HV metering equipment

#### 11.3.1 General

- (a) The metering installation contains the metering current transformers and the metering voltage transformers (metering instrument transformers). Wherever practicable this equipment shall be located within the *Proponent's* installation and be accessible to the Metering Provider. The metering installation shall comply with the requirements outlined in the AEMO Metrology Procedure Part A and the NER Chapter 7 and be approved by the Metering Coordinator.

- (b) The metering instrument transformers will remain the *Proponent's* property, and the *Proponent* will be responsible for maintaining, servicing and if failure occurs, replacing the metering instrument transformers in accordance with the requirements of the *NER*<sup>24</sup>.
- (c) The *Proponent* shall provide metering instrument transformers, associated equipment and plant and ensure it is ready for the nominated *Metering Provider* to connect metering and communication equipment.
- (d) The *Proponent* shall provide to the *Metering Provider* prior to installation of the equipment, Instrument Transformer test certificates in accordance with the requirements of the *NER* Schedules 7.2 and 7.3. Where metering instrument transformers are tested in:
  - (i) Australia - endorsed reports from a laboratory accredited by *NATA* are required; or
  - (ii) overseas - endorsed reports from a laboratory accredited by an organisation recognised by *ILAC* (International Laboratory Accreditation Cooperation) are required.
- (e) The *Proponent* shall supply, install and test the secondary wiring and meter enclosure/panel, and terminate the secondary wiring at the meter panel and the metering instrument transformers.
- (f) The *Proponent* shall provide readily accessible *HV* test points on either side of the metering instrument transformers, in the specification/design of their switchgear. This will enable the *Metering Provider* to conduct the periodic *HV* metering instrument transformer accuracy tests (e.g., primary injection tests), required by the *NER*, with minimal power outages and disruption to the *Proponent* and their equipment.
- (g) The *Proponent* shall specify, install, test and maintain the instrument transformers in accordance with the requirements of the *NER*, relevant Australian Standards including. *AS/NZS 3000*, *AS 2067*, *AS 61869* series and the *QECM*.

### 11.3.2 *HV* metering installation general requirements

The following general requirements apply to *HV* metering installations:

- (a) For *metering installations* greater than 1000 GWh pa per *connection point*, the current transformer core and secondary wiring associated with the meter(s) shall not be used for any other purpose unless otherwise agreed by *AEMO*.
- (b) For *metering installations* less than 1000 GWh pa per *connection point* the current transformer core and secondary wiring associated with the meter(s) may be used for other purposes (e.g., local metering or protection) provided the *Metering Coordinator* demonstrates to the satisfaction of *AEMO* that the accuracy of the *metering installation* is not compromised, and suitable procedures/measures are in place to protect the security of the *metering installation*.
- (c) The metering voltage instrument transformers may be used to supply *Proponents* metering at the discretion and approval of the *Metering Provider* on a case-by-case basis. The secondary voltage supply from the voltage transformers will be separately fused with fuses located in an accessible position as near as practicable to the voltage transformer secondary connection. The metering instrument transformers' secondary wiring is to be earthed at one point only in accordance with the *Metering Provider's* requirements.

---

<sup>24</sup> Any fault or defect is required to be rectified within 2 business days or the *Metering Coordinator* must obtain an exemption from *AEMO*.

- (d) The metering instrument transformers may be used to supply the *DNISP's* power quality monitoring equipment at the discretion and approval of the *Proponent* and *Metering Provider* on a case-by-case basis.

## 11.4 HV installation of metering equipment

The *Proponent* shall ensure that all requirements and steps in the *metering installation* process are coordinated in an efficient and timely manner to allow supply to be connected when required.

### 11.4.1 HV metering location

- (a) The metering point shall be located as close as practicable to the *connection point*.
- (b) Adequate and safe access must be provided for the installation, and routine and corrective maintenance of metering equipment in accordance with *AEMO* requirements.
- (c) The minimum spacing between the meter wiring and other current carrying conductors shall comply with *MIR*.

### 11.4.2 Metering enclosure

The following requirements apply to *HV* metering enclosures:

- (a) Unless otherwise detailed in the supply agreement the *Proponent* shall supply a pre-wired meter panel and enclosure to the requirements of the *Metering Provider*. Wiring diagrams can be obtained from the *Metering Provider*.
- (b) Any metering enclosure mounted externally shall have an appropriate IP rating and be positioned so that adequate mechanical protection is provided.
- (c) A hinged panel with minimum dimensions of 600 mm x 600 mm is required for the mounting of meters and metering test block on the same vertical surface.
- (d) A metering enclosure installed on a pole in association with a *DNISP* owned metering unit, will be supplied and maintained by the *DNISP*.
- (e) No *Proponent* owned equipment is to be installed within the *Metering Provider's* dedicated metering enclosure.
- (f) The supply and wiring of the meter panel may be carried out by the *Metering Provider* as part of a negotiated agreement.
- (g) The *Proponent* is responsible for earthing of the metering enclosure in accordance with relevant standards and practices including consideration for earth potential rise.
- (h) The *Proponent* should consider providing lockable front meter doors in locations where security may be an issue.
- (i) Meters and control equipment shall be positioned so that they are not subjected to mechanical damage, vibration, high temperature or other environmental situations that might affect their correct operation (e.g., exposure to direct sunlight).

### 11.4.3 Secondary wiring

The following requirements apply to metering units supplied by the *Metering Provider* and metering instrument transformers owned and installed by the *Proponent*:

- (a) The *Proponent* shall supply and install the secondary wiring between the metering instrument transformers and the test block or terminal strip.
- (b) Metering instrument transformer secondary wiring is to follow the most direct route and the number of terminations and links shall be kept to a minimum.
- (c) Metering instrument transformer secondary wiring is to be PVC insulated stranded cable of no more than 7 strands.

- (d) The secondary wiring shall be sized to ensure that the burden on the metering instrument transformers is not exceeded.
- (e) All taps of multi-tap CTs to be brought out to the marshalling box or *metering enclosure* (in the absence of a marshalling box).
- (f) Any *connection point* in the metering instrument transformers' secondary circuit (terminals, links, fuses etc.) that is accessible shall be identified as "Revenue Metering" and shall be able to be covered and sealed.

## 11.5 Testing requirements

- (a) The *Proponent* shall meet the cost of any *HV* testing as required by AS 2067, *NER* and auditing in accordance with the Electrical Safety Act 2002 (Qld).
- (b) The *Metering Coordinator* shall ensure that *HV* metering instrument transformers are tested and maintained in accordance with the *NER*.

## 11.6 Operation of *HV* equipment

- (a) The *Proponent* is responsible for ensuring that the *HV* installation is operated in accordance with the requirements of the Electrical Safety Act 2002 (Qld), the Electrical Safety Regulation 2013 (Qld) and the Code of Practice for Electrical Work.
- (b) The *Proponent* has an obligation to ensure all persons who are involved in the *HV* isolation and access procedures have been trained and assessed as competent to perform the roles for which they are responsible.
- (c) Testing, earthing and safety equipment suitable for operation of the *HV* equipment shall be readily available on site.
- (d) For *HV* installations consisting of more than one item of switchgear, an operating diagram in the form of a single line schematic of the complete installation is to be permanently displayed adjacent to the main switch or switches.
- (e) Where items of switchgear are remote from the main switchboard, it is recommended that the operating diagram also be permanently displayed at these locations.

## 11.7 Maintenance and repairs of *HV* equipment

- (a) A *Proponent* who takes supply at *HV* shall ensure that the *HV* installation is maintained so that any malfunction will not create a hazard or cause interference to the *DNSP's* supply.
- (b) All costs associated with the maintenance or repairs of the *Proponent's* *HV* installation shall be met by the *Proponent*.
- (c) The *Proponent* shall be prepared for power interruptions during *HV* testing procedures, maintenance, or repairs.

## 12 Testing and commissioning

### 12.1 LV connections

Testing and commissioning requirements for connections of *electrical installations* to the *LV distribution system* include:

- (a) Testing and commissioning plans shall be prepared by the *Proponent* and may be required to be approved by the *DNISP* under the *connection contract*.
- (b) Where a design or commissioning activities require engineering services, the commissioning plan, certification and acceptance shall be provided by an *RPEQ*.
- (c) Initial connection or reconnection to the *distribution system* shall meet the requirements of clause 4.6.
- (d) Testing and commissioning acceptance may require the *DNISP* to carry out witnessing.
- (e) Mains polarity and neutral integrity tests shall be conducting in accordance with AS 4741 for LV connections. *Electrical Contractors* shall use the testing and commissioning check sheets in Appendix F for connections with direct connect or CT metering respectively.
- (f) For connections with multiple *electrical installations*, an electrical test shall be completed to confirm that the meter wiring supplies the part of the *electrical installation* that is identified by the switchboard and unit marking. The test shall confirm a correct relationship between the *National Metering Identifier (NMI)*, the meter number/s and the address.
- (g) Testing and commissioning for *EG systems* shall meet the requirements of the relevant *EG system* standards in clause 8.15.1.
- (h) The *DNISP* shall conduct examination and testing as per the requirements in clause 4.6 for initial connections and reconnections to the *distribution system*.
- (i) Testing and commissioning requirements shall be in accordance with AS/NZS 3000, relevant statutory requirements and standards, the equipment manufacturer's specifications and the *DNISP* technical requirements to demonstrate the installation complies with the requirements set out in the *connection contract*.
- (j) The *Proponent* shall submit an *EWR* and where required in the *connection contract*, a compliance report as that comprises (but is not limited to) the final approved drawings, test results and specifications.
- (k) A *DNISP* may undertake investigations, examination and testing at a connection for safety, compliance or quality of supply purposes.
- (l) Where a *Proponent* is classified as a *Major Customer* as per STNW3522, meet any additional testing and commissioning requirements as per STNW3522.

### 12.2 HV connections

Testing and commissioning requirements for connections of *electrical installations* to the *HV distribution system* include:

- (a) All new or modified *HV electrical installations* shall have a pre-commissioning inspection by an *Accredited auditor* before connection to supply from the *distribution system*.<sup>25</sup>
- (b) Initial connection or reconnection to the *distribution system* shall meet the requirements of clause 4.6.

---

<sup>25</sup> The auditor should be involved in the project at an early stage. For additional information on *Accredited auditors* refer to the Electrical Safety Office (Qld).

- (c) Testing and commissioning plans shall be prepared by the *Proponent* and may be required to be approved by the *DNISP* and *AEMO* as required under the *connection contract*.
- (d) Testing and commissioning of *HV* metering shall meet the requirements of clause 11.5.
- (e) The commissioning plan, certification and acceptance shall be provided by an *RPEQ*.
- (f) Notice shall be given not less than three months prior to commencement of commissioning.
- (g) All pre-requisites, including SCADA connection, background recordings, curtailment scheme completion and pre-commissioning activities shall have been completed as relevant for the particular site.
- (h) Testing and commissioning acceptance may require the *DNISP* to carry out witnessing at the *Proponent's* expense.
- (i) Testing and commissioning shall meet the requirements of STNW3522.
- (j) Testing and commissioning for *EG systems* shall meet the requirements of the relevant *EG system* standard in clause 8.15.1.
- (k) The *DNISP* shall conduct examination and testing as per the requirements in clause 4.6 for initial connections and reconnections to the *distribution system*.
- (l) Testing and commissioning requirements shall be in accordance with AS 2067, relevant statutory requirements and standards, the equipment manufacturer's specifications and the *DNISP* technical requirements to demonstrate the installation complies with the requirements set out in the *connection contract*.
- (m) The *Proponent* shall submit a compliance report that comprises (but is not limited to) the final approved drawings, installed settings, test results and specifications. The compliance report has checks to confirm compliance to this *manual* and any connection-specific *technical study*.
- (n) A *DNISP* may undertake investigations, examination and testing at a connection for safety, compliance, or quality of supply purposes.
- (o) The *Proponent* and *DNISP* may need to test and commission any operating protocol for the connection.
- (p) The *Metering Coordinator* shall ensure that *HV* metering instrument transformers are tested in accordance with the *NER*.

## 13 Operations and maintenance

### 13.1 Proponent obligations

Operations and maintenance requirements for *Proponent's electrical installations* shall include, but are not limited to:

- (a) Where required under a EG Standard in clause 8.15.1 or legislation an operation and maintenance plan shall be produced, with a copy to remain on site.
- (b) The *Customer* shall maintain clear level and safe access to the *point of attachment* to allow the *DNISP* to maintain the *DNISP service point* and *connection assets* as per clause 6.4, clause 6.6 and clause 7.4 as relevant.
- (c) The *electrical installation* connected equipment and *EG System* shall be operated and maintained to ensure compliance at all times with the relevant *connection agreement* and all applicable legislation (including *energy laws*), codes, and/or other regulatory instruments.
- (d) Operation and maintenance reports may be required by the *DNISP* at a specified interval no more frequently than annually unless required under applicable legislation.
- (e) Subject to item (f) below, the *Proponent* shall ensure that any changes to the *electrical installation* at the supply address are performed by an electrician lawfully permitted to do the work and that the *Proponent* holds a Certificate of Compliance issued in respect of any of the changes.
- (f) The *electrical installation* at the supply address shall be maintained in a safe condition.
- (g) Where a *Proponent* is classified as a Major *Customer* as per STNW3522 they shall notify the *DNISP* of any scheduled and unscheduled protection or communications outages or failures.
- (h) The *Metering Coordinator* shall ensure that *HV* metering instrument transformers are maintained in accordance with the *NER*.

### 13.2 Dynamic operation

An actively managed DER system with *dynamic* operation shall operate fixed or *dynamic* limits as per Table 57:

**Table 57 Dynamic operation criteria**

Operation function	Requirements
Fixed limits	<ul style="list-style-type: none"> <li>• Connection agreement for a <i>dynamic</i> load or <i>EG system</i>.</li> <li>• Installed in accordance with this Standard.</li> </ul>
<i>Dynamic</i> limits	<ul style="list-style-type: none"> <li>• Connection agreement for a <i>dynamic</i> load or <i>EG system</i>.</li> <li>• Installed in compliance with this <i>manual</i> and referenced <i>dynamic</i> connection standards.</li> <li>• Registered to the <i>DNISP</i> IEEE SEP2 Utility Server.</li> <li>• Receive <i>dynamic export, import</i> and/or generation limits.</li> <li>• Operate <i>dynamic EG System</i> to meet <i>export, import</i> and generation limits.</li> </ul>

### 13.3 DNISP obligations

- (a) The *DNISP* may at its own cost inspect the *Proponent's DNISP service point* at any time.

- (b) Where an urgent safety concern is suspected the *DNISP* may at its own cost enter the *Proponent's premises* to inspect and rectify to safe the *electrical installation*.
- (c) The *DNISP* may require access to the site of a specific part of an *electrical installation* such as a distribution board, equipment, the *GSD*, an *EG System* and isolation points for *distribution system* maintenance and testing purposes.
- (d) If the *DNISP* through an audit or an investigation determines that the *electrical installation* or part of the *electrical installation* is non-compliant with the connection agreement, the *Proponent* shall be advised of this in writing. If the concern has a material impact, the *DNISP* shall disconnect the *electrical installation* or part of the *electrical installation*, such as *electrical equipment* or an *EG system*, until the non-compliance has been remediated by the *Proponent* to the *DNISP's* satisfaction.

## 13.4 *Distribution system maintenance*

*Distribution system* maintenance may cause interruptions to the operation of the *electrical installation*. Co-operative scheduling of these activities may be able to be facilitated to reduce the outage period and minimise the associated impacts.

# Queensland Electricity Connection Manual



Part of Energy Queensland

## Appendix A: QECM drawings (normative)

See drawings on following pages. Drawings can also be accessed individually on the *DNSP* website details are available in Appendix N.

## A.1: Section 5 – General connection and supply requirement drawings

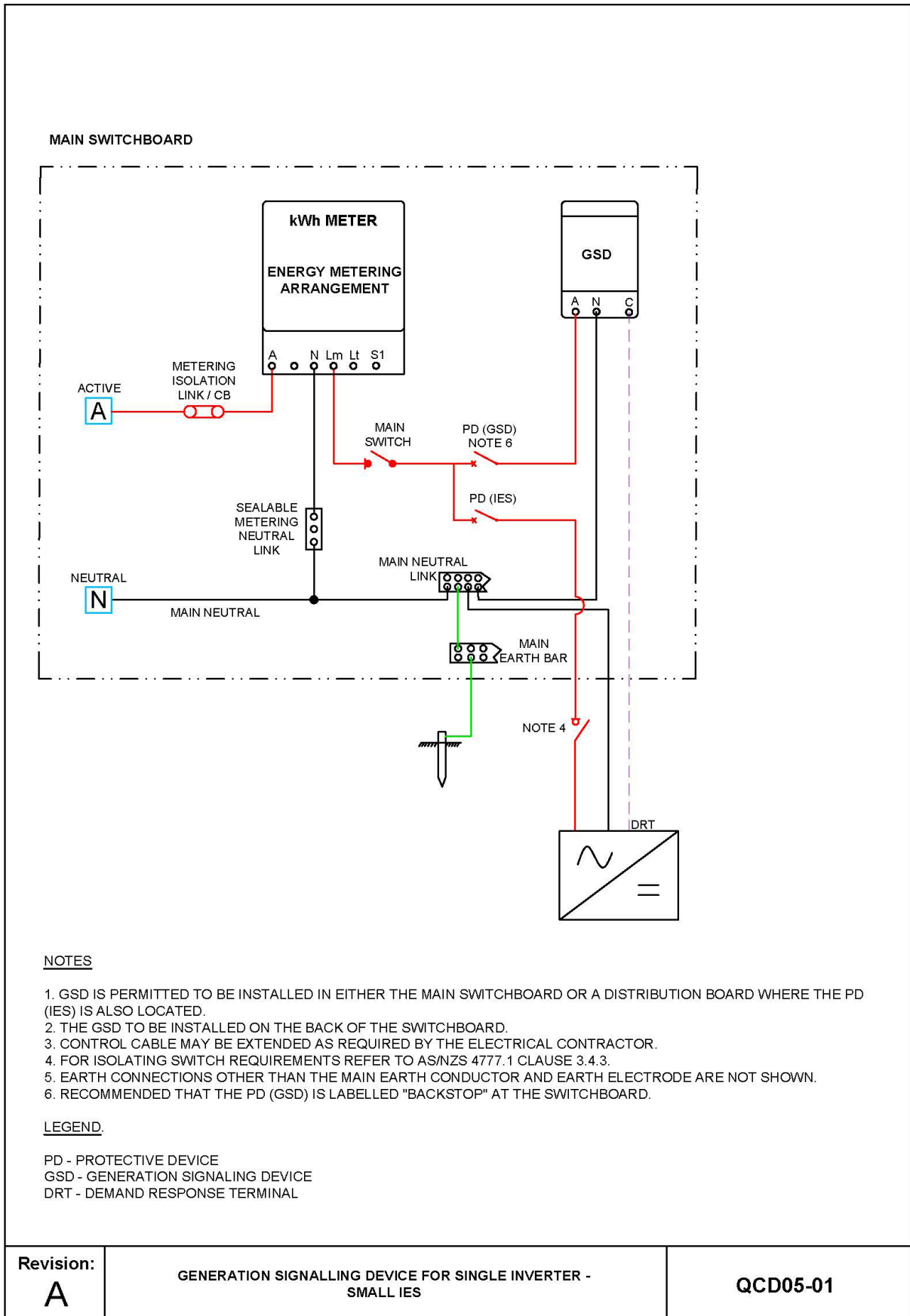

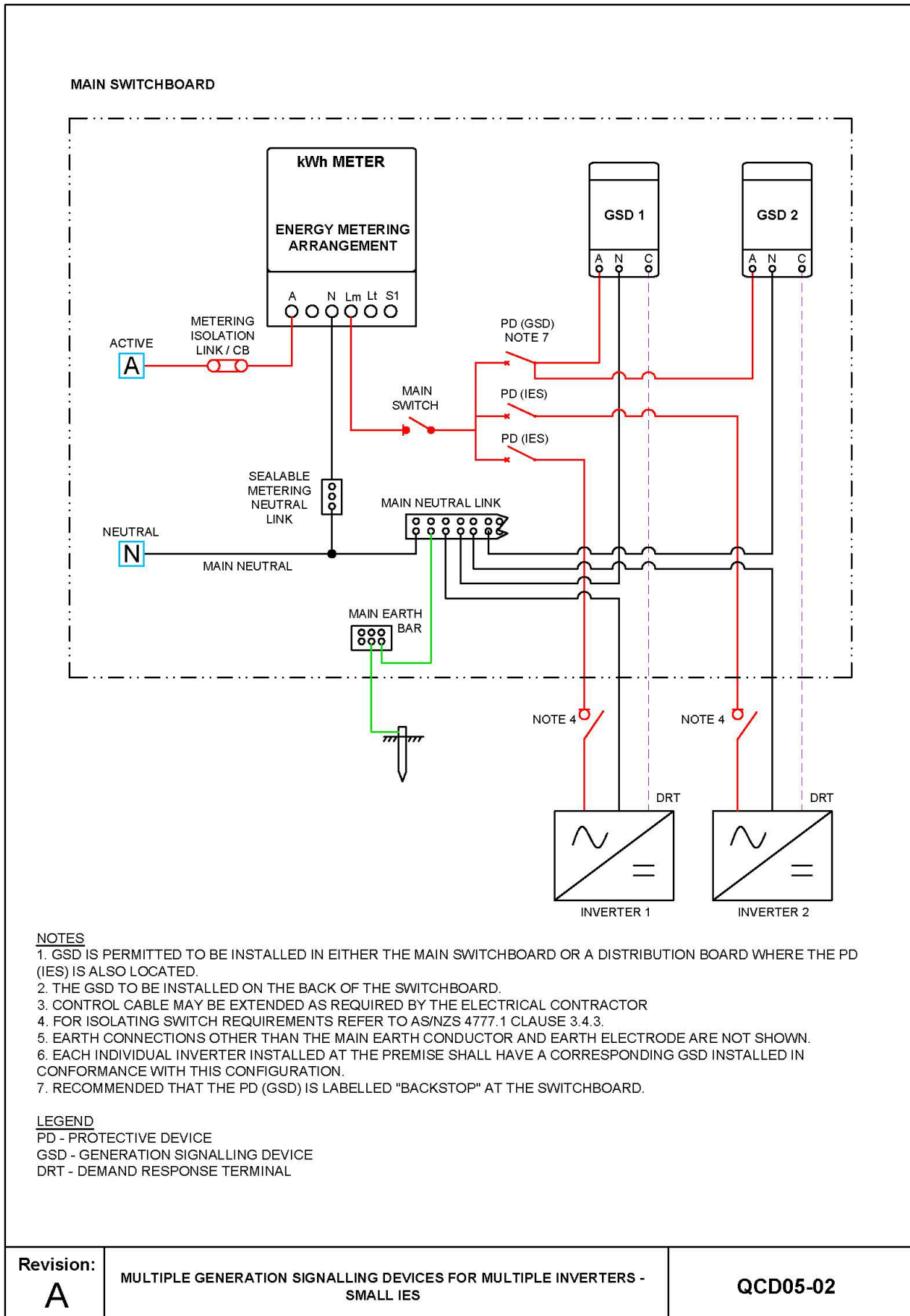

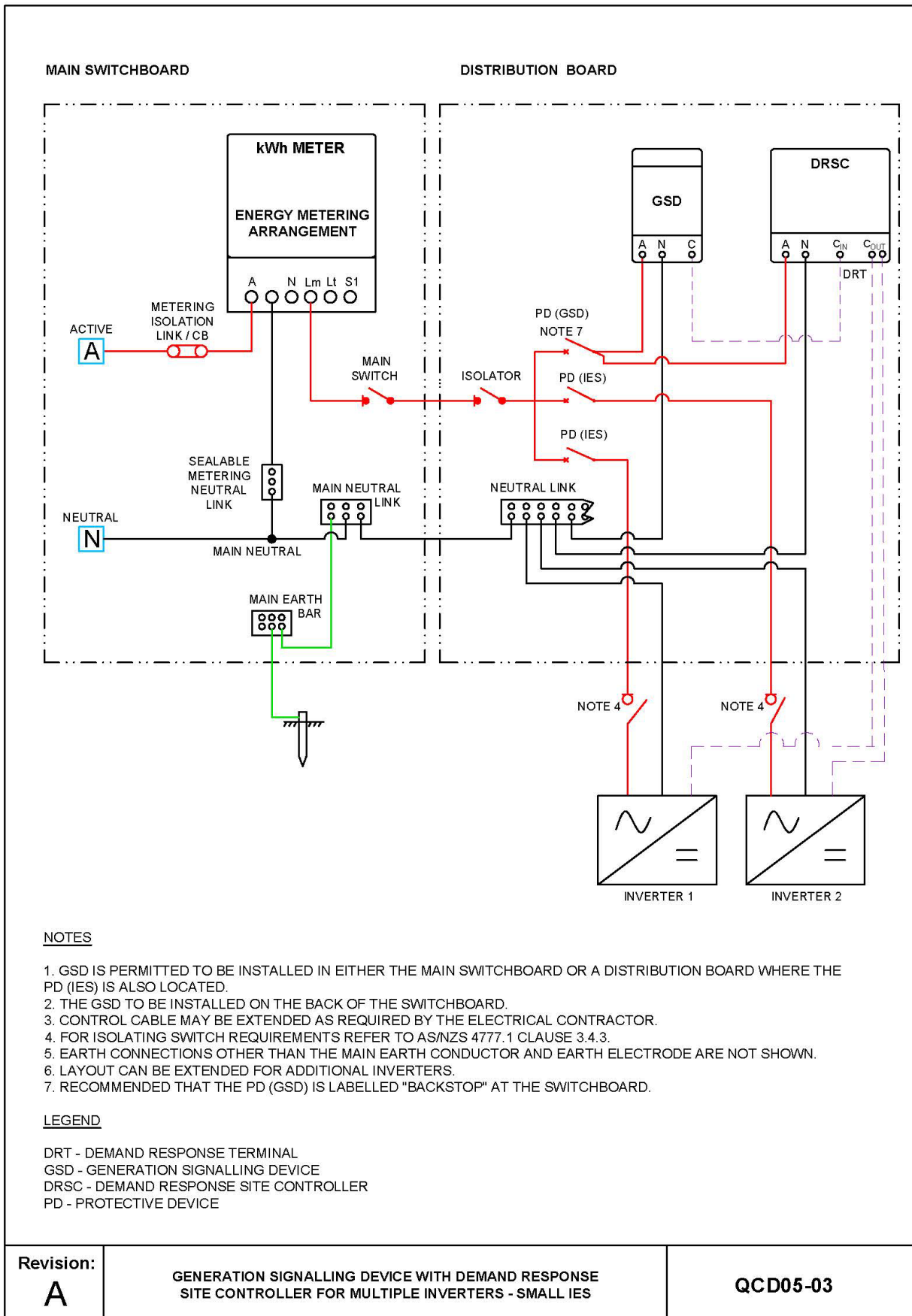

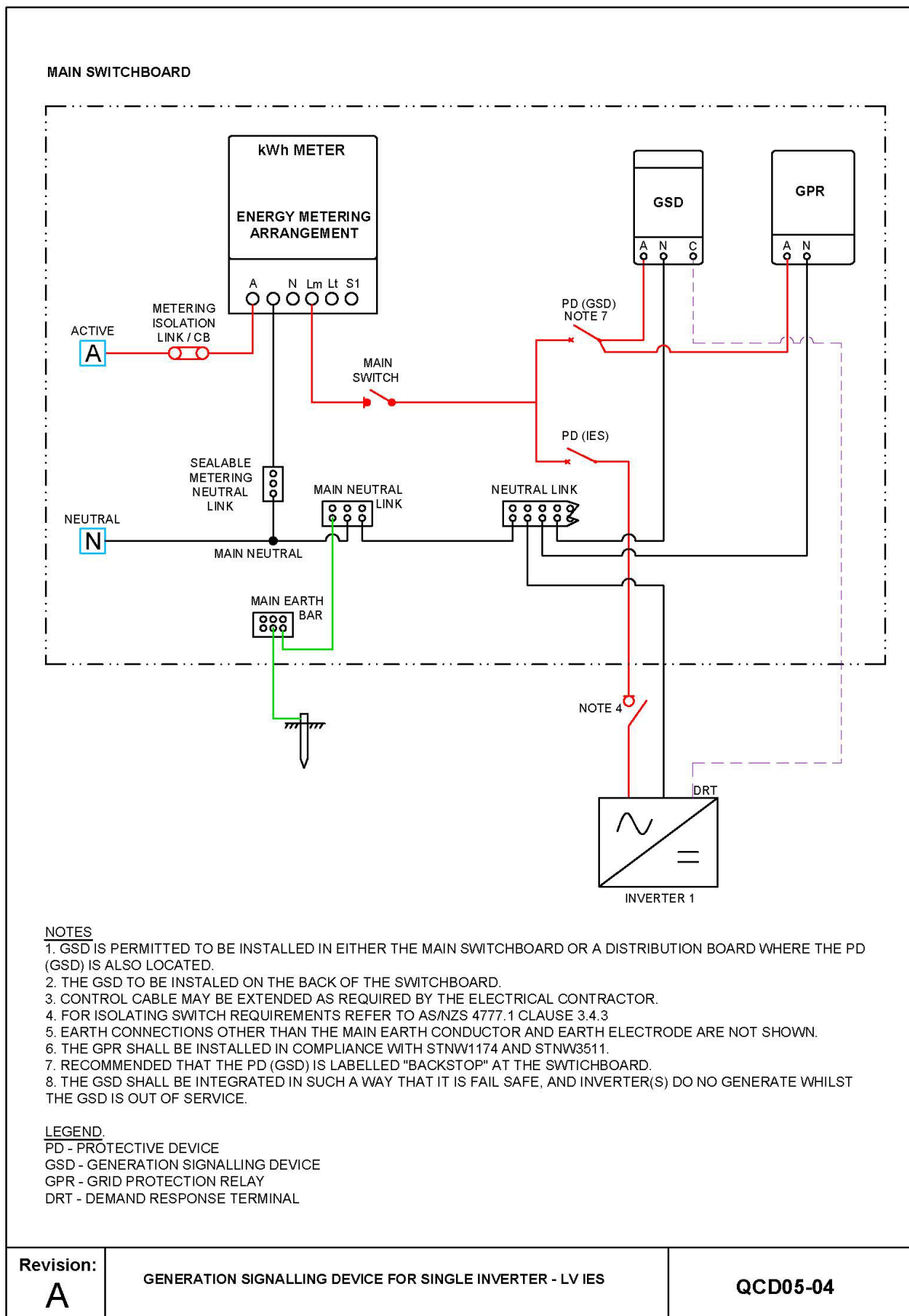

## MAIN SWITCHBOARD

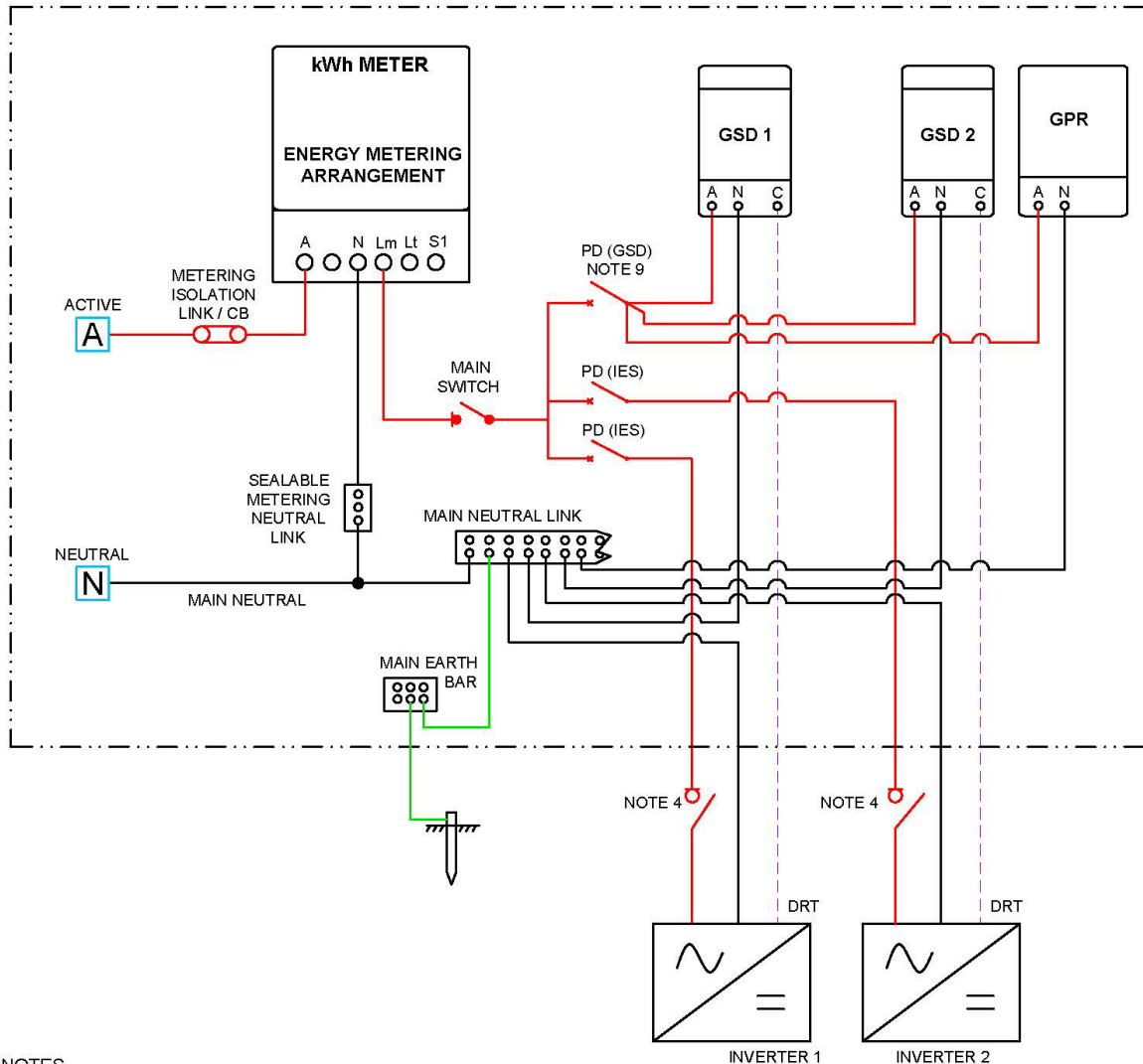

### NOTES

1. GSD IS PERMITTED TO BE INSTALLED IN EITHER THE MAIN SWITCHBOARD OR A DISTRIBUTION BOARD WHERE THE PD (IES) IS ALSO LOCATED.
2. THE GSD TO BE INSTALLED ON THE BACK OF THE SWITCHBOARD.
3. CONTROL CABLE MAY BE EXTENDED AS REQUIRED BY THE ELECTRICAL CONTRACTOR
4. FOR ISOLATING SWITCH REQUIREMENTS REFER TO AS/NZS 4777.1 CLAUSE 3.4.3.
5. EARTH CONNECTIONS OTHER THAN THE MAIN EARTH CONDUCTOR AND EARTH ELECTRODE ARE NOT SHOWN.
6. EACH INDIVIDUAL INVERTER INSTALLED AT THE PREMISE SHALL HAVE A CORRESPONDING GSD INSTALLED IN CONFORMANCE WITH THIS CONFIGURATION.
7. THE GPR SHALL BE INSTALLED IN COMPLIANCE WITH STNW174 AND STNW3511.
8. RECOMMENDED THAT THE PD (GSD) IS LABELLED "BACKSTOP" AT THE SWITCHBOARD.
9. THE GSD SHALL BE INTEGRATED IN SUCH A WAY THAT IT IS FAIL SAFE, AND INVERTER(S) DO NOT GENERATE WHILE THE GSD IS OUT OF SERVICE.

### LEGEND

- PD - PROTECTIVE DEVICE  
 GSD - GENERATION SIGNALLING DEVICE  
 DRT - DEMAND RESPONSE TERMINAL  
 GPR - GRID PROTECTION RELAY

<b>Revision:</b>	<b>MULTIPLE GENERATION SIGNALLING DEVICES FOR MULTIPLE INVERTERS - LV IES</b>	<b>QCD05-05</b>
<b>A</b>		



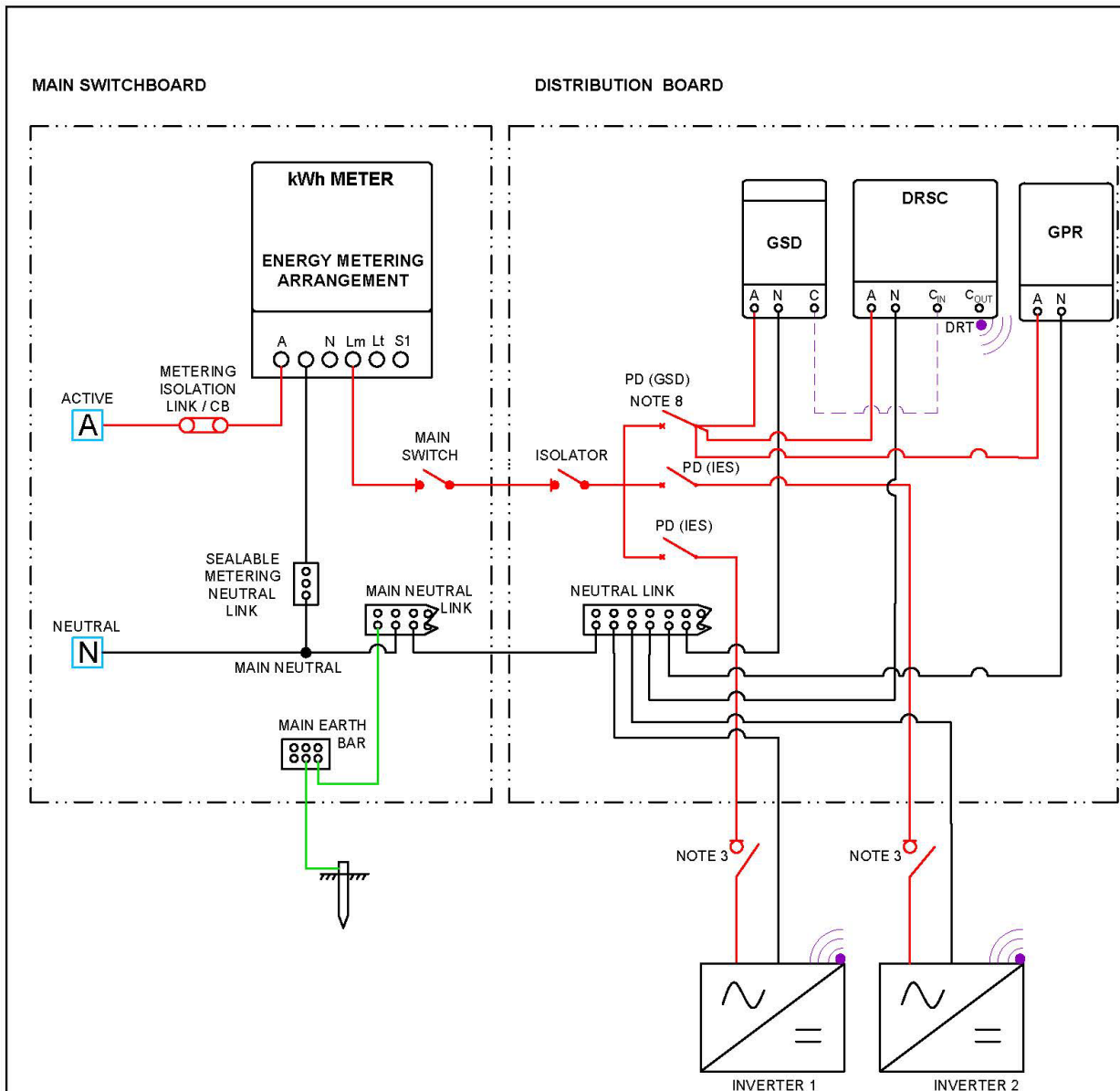

**NOTES**

1. GSD IS PERMITTED TO BE INSTALLED IN EITHER THE MAIN SWITCHBOARD OR A DISTRIBUTION BOARD WHERE THE PD (IES) IS ALSO LOCATED.
2. THE GSD TO BE INSTALLED ON THE BACK OF THE SWITCHBOARD.
3. FOR ISOLATING SWITCH REQUIREMENTS REFER TO AS/NZS 4777.1.2016 CLAUSE 3.4.3.
4. EARTH CONNECTIONS OTHER THAN THE MAIN EARTH CONDUCTOR AND EARTH ELECTRODE ARE NOT SHOWN.
5. LAYOUT CAN BE EXTENDED FOR ADDITIONAL INVERTERS.
6. RECOMMENDED THAT THE PD (GSD) IS LABELLED "BACKSTOP" AT THE SWITCHBOARD.
7. THE GPR SHALL BE INSTALLED IN COMPLIANCE WITH STNW1174 OR STNW3511.
8. THE GSD SHALL BE INTEGRATED IN SUCH A WAY THAT IT IS FAIL SAFE, AND INVERTER(S) DO NO GENERATE WHILST THE GSD IS OUT OF SERVICE.
9. THE WIRELESS CONFIGURATION SHALL MEET THE REQUIREMENTS OF CLAUSE 8.10.2(h)

**LEGEND**

- DRT - DEMAND RESPONSE TERMINAL
- GSD - GENERATION SIGNALLING DEVICE
- DRSC - DEMAND RESPONSE SITE CONTROLLER
- PD - PROTECTIVE DEVICE
- GPR - GRID PROTECTION RELAY

<b>Revision:</b> <b>A</b>	<b>GENERATION SIGNALLING DEVICE WITH DEMAND RESPONSE SITE CONTROLLER FOR MULTIPLE INVERTERS - WIRELESS CONNECTION TO LV IES</b>	<b>QCD05-07</b>
------------------------------	---	-----------------

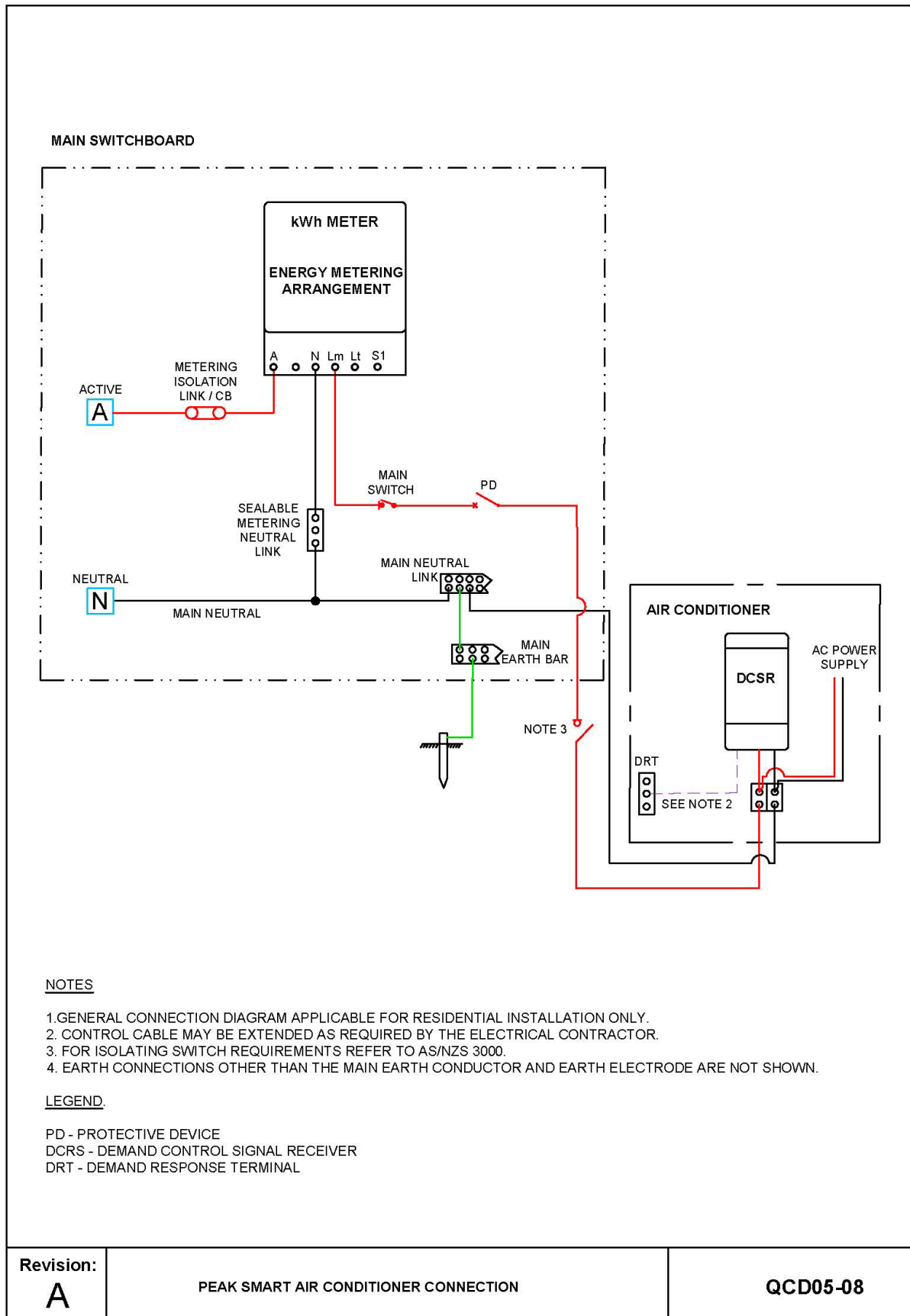

# Queensland Electricity Connection Manual

## A.2: Section 6 – Overhead connection and supply requirement drawings

**OVERHEAD SERVICE CLEARANCES**

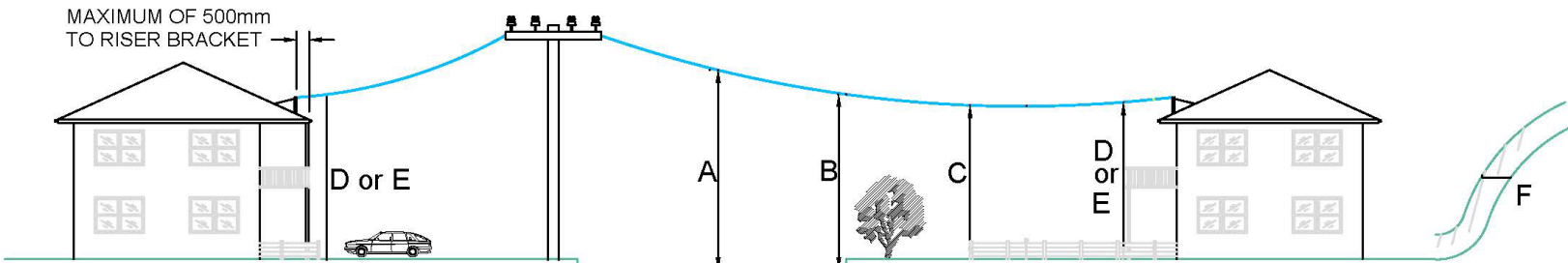

**SERVICE CLEARANCE TABLE**

CATEGORY		CODE	LOCATION	DIRECTION	MINIMUM CLEARANCE
NEUTRAL SCREENED AND INSULATED CABLES	ROADS	A	At centre-line of the carriageway	VERTICALLY	5.5m
		B	At kerb line (bottom of kerb)	VERTICALLY	4.9m
		C	At fence alignment	VERTICALLY	3.7m
	OTHER	D	Private driveways and areas including elevated areas used by vehicles	VERTICALLY	4.5m
		E	Areas not normally used by vehicles	VERTICALLY	2.7m
		F	Road cuttings, embankments and other similar places.	HORIZONTALLY	1.5m

**NOTES :**

1. Stated clearances apply to a service line not attached to the part of the building described.
2. Where there is no formed footpath, the kerb line means:
  - the kerb line of a proposed footpath; or
  - where no footpath is proposed, the edge of the existing carriageway or any proposed widening thereof.
  - where there is a formed footpath with kerb and channel the kerb line means to the bottom of the channel.
3. The clearances above and adjacent to sugar cane, both green and burnt cane areas, are outlined in the Overhead Construction Manual.

Revision: <b>A</b>	<b>OVERHEAD SERVICE CLEARANCES FROM GROUND</b>	<b>QCD06-01</b>
-----------------------	--	-----------------

## OVERHEAD SERVICE CLEARANCES

NO CLEARANCE LIMITS IN VICINITY OF POA (NOTE 4)

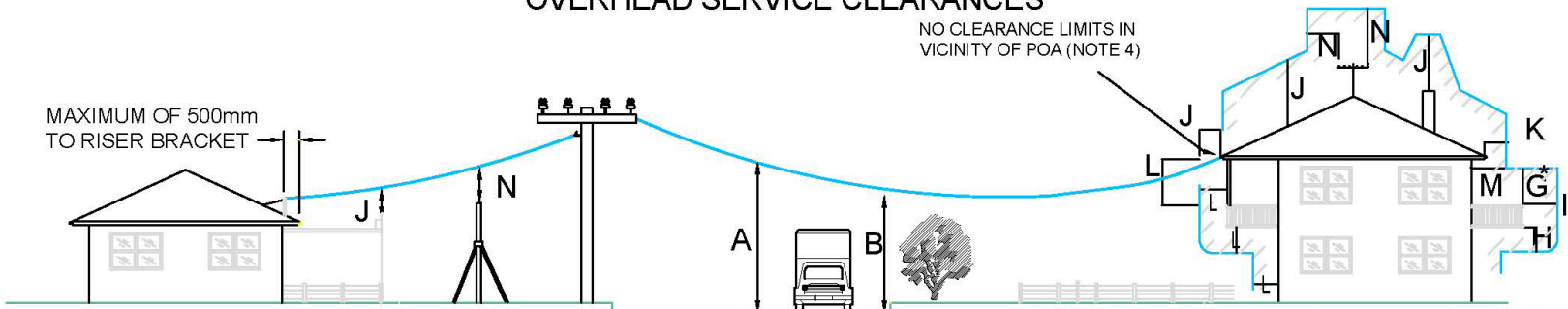

\* Applies from where a person is LIKELY to stand as determined by site risk assessment.

### SERVICE CLEARANCE TABLE

CATEGORY	CODE	LOCATION	DIRECTION	MINIMUM CLEARANCE
NEUTRAL SCREENED AND INSULATED CABLES	G	Unroofed terraces, balconies, sun-decks, paved areas, and similar areas that are subject to pedestrian traffic only, that have a hand rail or wall surrounding the area and on which a person is likely to stand (Note 2) must be-	VERTICALLY ABOVE	2.4m
	H		VERTICALLY BELOW	1.2m
	I		HORIZONTALLY (Note 1)	0.9m
	J	Roofs or similar structures not used for traffic or resort but on which a person is likely to stand, and for parapets surrounding roofs or similar structures not used for traffic or resort but on which a person is likely to stand (Note 2) must be-	VERTICALLY	0.5m
	K		HORIZONTALLY (Note 1)	0.2m
	L	Covered places of traffic or resort including for example windows which are capable of being opened, roofed open verandahs and covered balconies must be (Note 5)	IN ANY DIRECTION	1.2m
M	Blank walls, windows which cannot be opened (Note 3) must be-	HORIZONTALLY	0.2m	
		Other structures not normally accessible to persons (Note 3) must be-	IN ANY DIRECTION	1.2m

**NOTES :**

- Either the vertical clearance or the horizontal clearance stated must be maintained. Also in, the zone outside the vertical alignment of the building or structure, either the horizontal clearance from the vertical alignment, or vertical clearance above the horizontal level on which a person is likely to stand must be maintained.
- For the purpose of the service clearance determination a person is considered LIKELY TO STAND ON:
  - A part of a structure that is strong enough to support a person's weight; and
  - A surrounding wall or handrail where the wall or handrail is at least 200mm wide.
- Stated clearances apply to a service line not attached to the part of the building described.
- The clearance stated does not apply to the part of the low voltage overhead service line not under tension. Drip loops are excluded and consideration should be given to drip loop positioning. (Note: Point of supply is to be not more than 600mm from the point of attachment).
- Where a window sill is determined as not being a place a person is likely to stand (eg. hopper windows, security screened windows and sliding windows) a clearance of 2.4m vertically from floor or 1.2m horizontally shall apply.

<b>Revision:</b> <b>A</b>		<b>OVERHEAD SERVICE CLEARANCES FROM STRUCTURES</b>	<b>QCD06-02</b>
------------------------------	--	--	-----------------

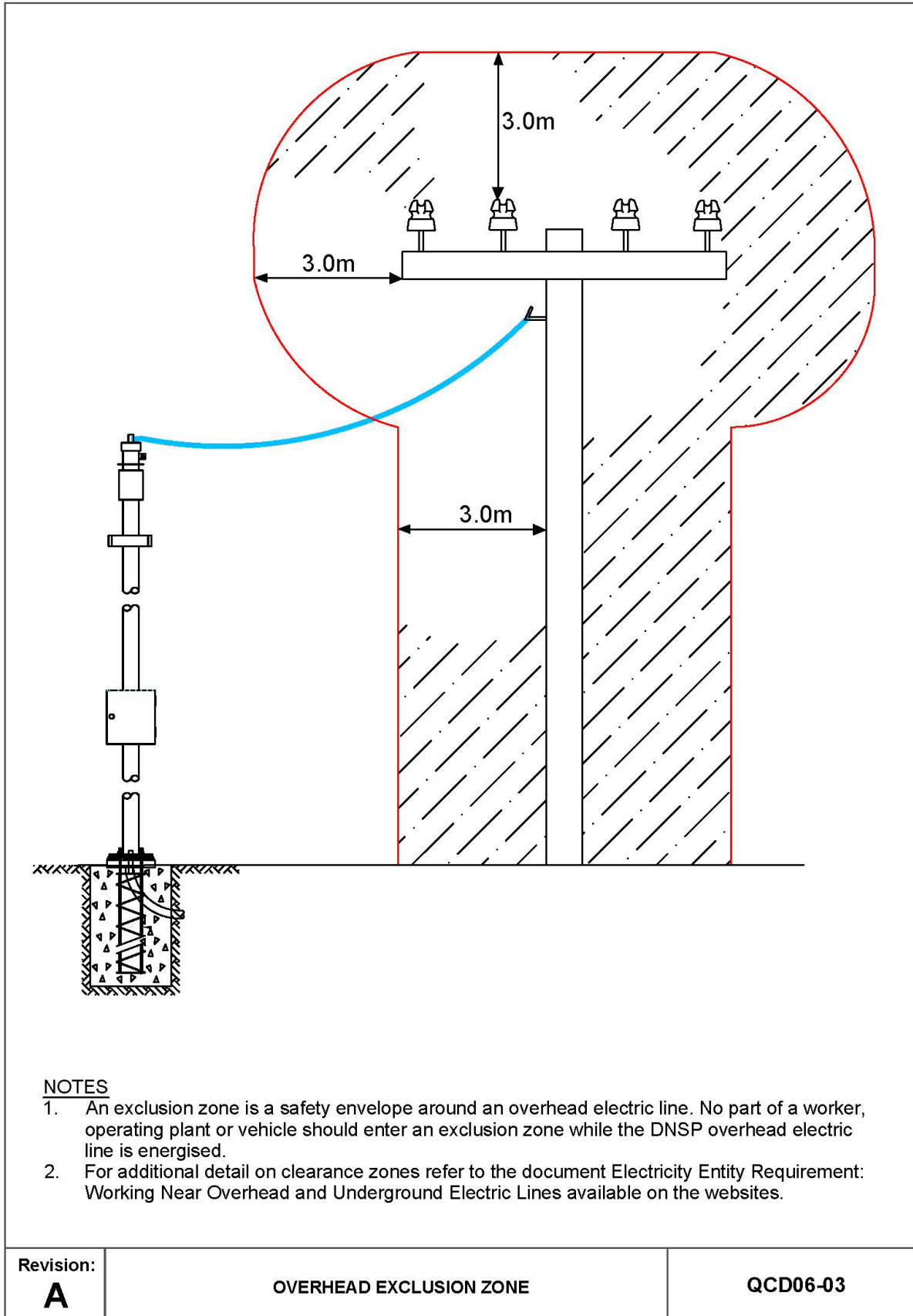

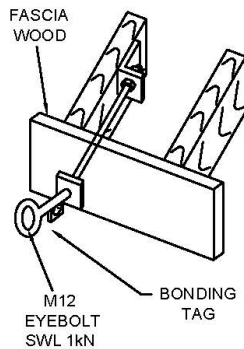

**EYEBOLT - TYPE 1**

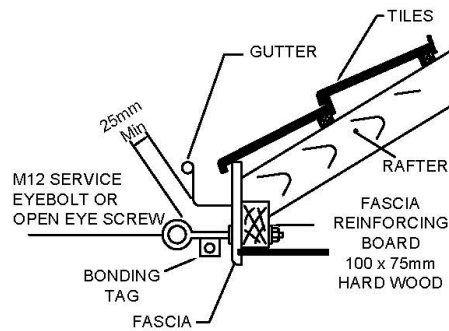

**EYEBOLT - TYPE 2**

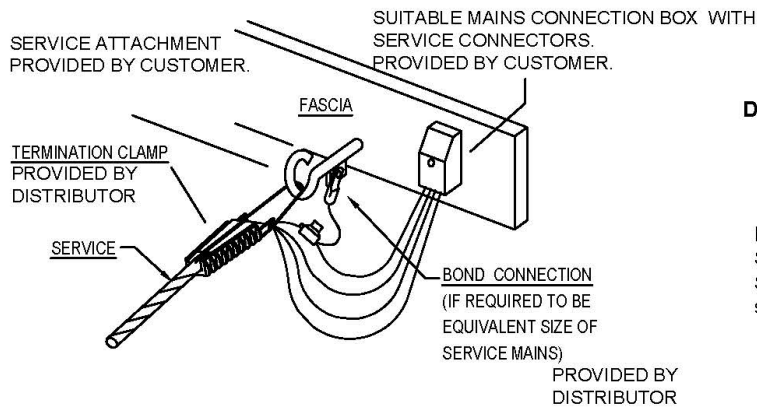

THREE PHASE SERVICE ARRANGEMENT SHOWN

**DIRECTION OF SERVICE - EYEBOLT**

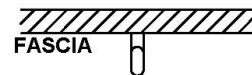

**EYEBOLT**  
Service permitted in any required position. Service must not come in contact with any structure and statutory clearances apply.

**NOTES**

1. Proponent to supply and install suitable mains connection box or non-metallic UV stabilised weatherproof enclosure. Refer to Clause 6.7.4 for minimum size requirements.
2. To prevent corrosion copper conductors shall not be directly connected to galvanised surfaces.
3. Manufacturers and Registered Professional Engineer Qld (RPEQ) installation instructions are to be followed in all cases - the detail in this drawing is **INFORMATIVE ONLY**.
4. Eyebolts are to be Hot Dipped Galvanised Steel and marked with a suitable 'SWL rating'.
5. 1kN raiser brackets must not be used to terminate 50/95mm<sup>2</sup> LVABC service. A 3.5kN raiser bracket or an eyebolt/open eye screw installed on a suitable portion of the building or a property pole is to be used.
6. If the service bracket/eyebolt is within 25mm of any structural metal work e.g. guttering or metal fascia of the building, the distributor will bond between the service attachment and the neutral conductor of the service.
7. The customer is to provide suitable means to connect bonding conductor. ie. Earth tag with 12mm hole.

<b>Revision:</b> <b>A</b>	<b>OVERHEAD 25/35mm<sup>2</sup> SERVICE ATTACHMENT TO FACIA (1.0kN) CONNECTION AND BRIDGING DETAILS</b>	<b>QCD06-04</b>
------------------------------	---	-----------------

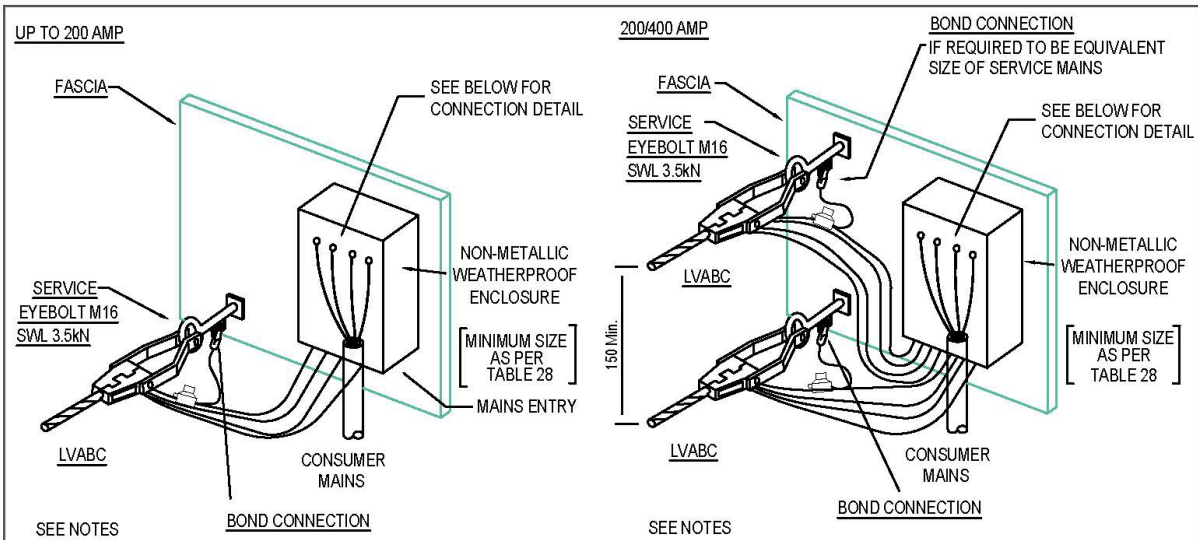

**SINGLE SERVICE LINE CONNECTION DETAIL**

**PARALLEL SERVICE LINES CONNECTION DETAIL**

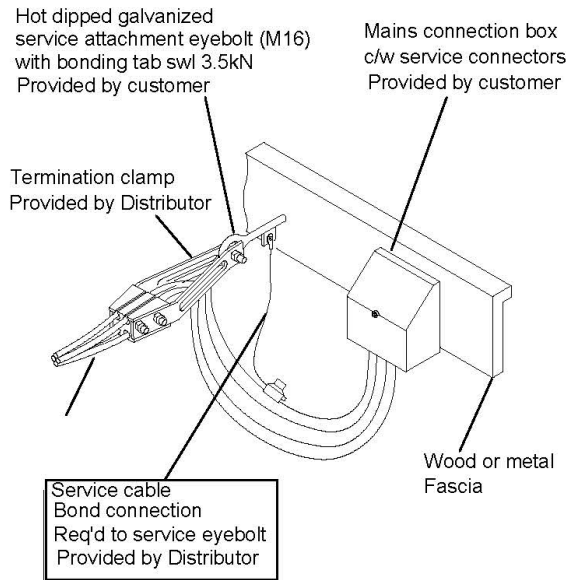

**50/95mm LV ABC SERVICE CONNECTION  
WOOD OR METAL FASCIA - 3.5kN SWL**

**NOTES**

1. Proponent to supply and install suitable mains connection box or non-metallic UV stabilised weatherproof enclosure and suitable lugs. Refer to Clause 6.7.4 for minimum size requirements.
2. Proponent to supply and install lugs to suit current rating of consumer mains and service line. Proponent shall accommodate a 12mm S/S bolt and lug dies where required.
3. Consumer mains to enter through bottom of enclosure.
4. The bonding of exposed metalwork (eyebolt) must use a conductor size the same as the service line neutral.
5. IPC's must be used to connect all earthing conductors to service line neutral.

<b>Revision:</b> <b>A</b>	<b>OVERHEAD 50/95mm<sup>2</sup> SERVICE ATTACHMENT TO FACIA (3.5kN) CONNECTION AND BRIDGING DETAIL</b>	<b>QCD06-05</b>
------------------------------	--	-----------------

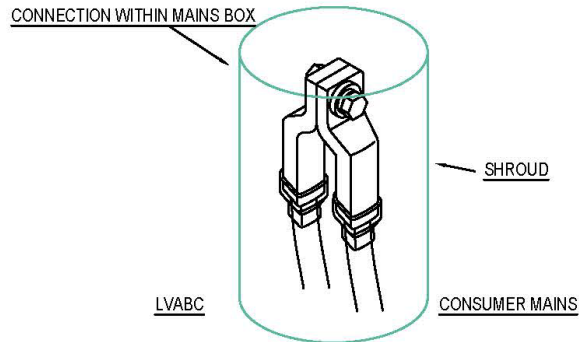

**LVABC CONNECTION TO SINGLE CONSUMER MAINS**

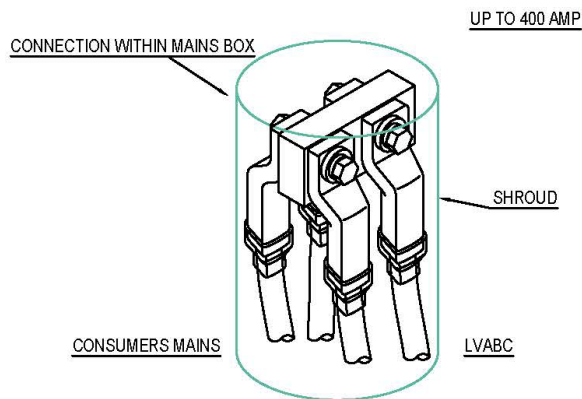

**LVABC CONNECTION TO PARALLEL CONSUMER MAINS**

**NOTES**

1. Proponent to supply and install lugs to suit current rating of consumer mains and service line. Proponent shall accommodate a 12mm stainless steel bolt and lug dies where required.
2. Alternative connections method use appropriate copper bus bar.
3. Cover with insulating shroud and secure with zip tie.

Revision:  
**A**

**OVERHEAD 50/95 mm<sup>2</sup> SERVICE ATTACHMENT MAINS BOX  
CONNECTION DETAILS**

**QCD06-06**

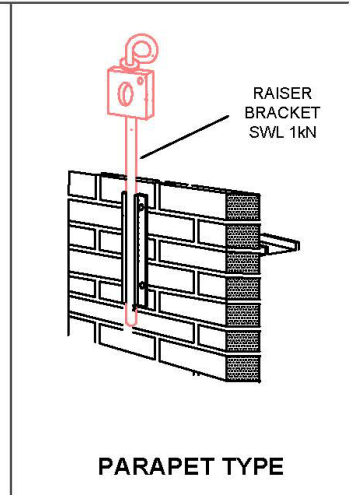
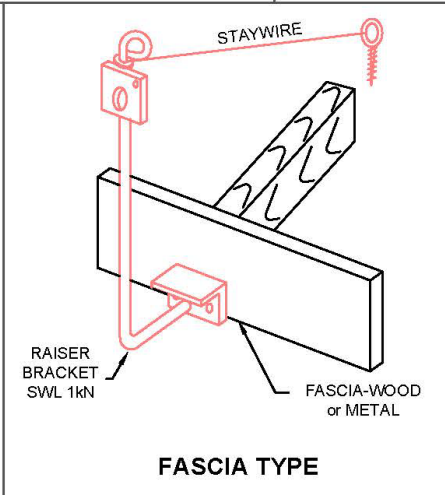
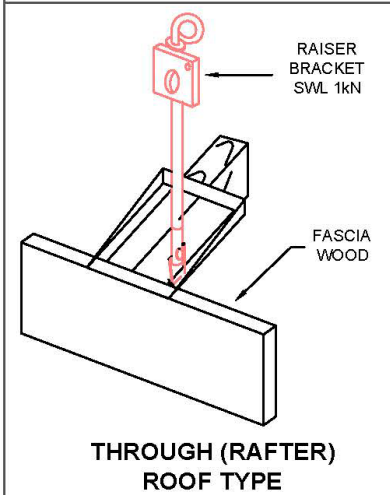
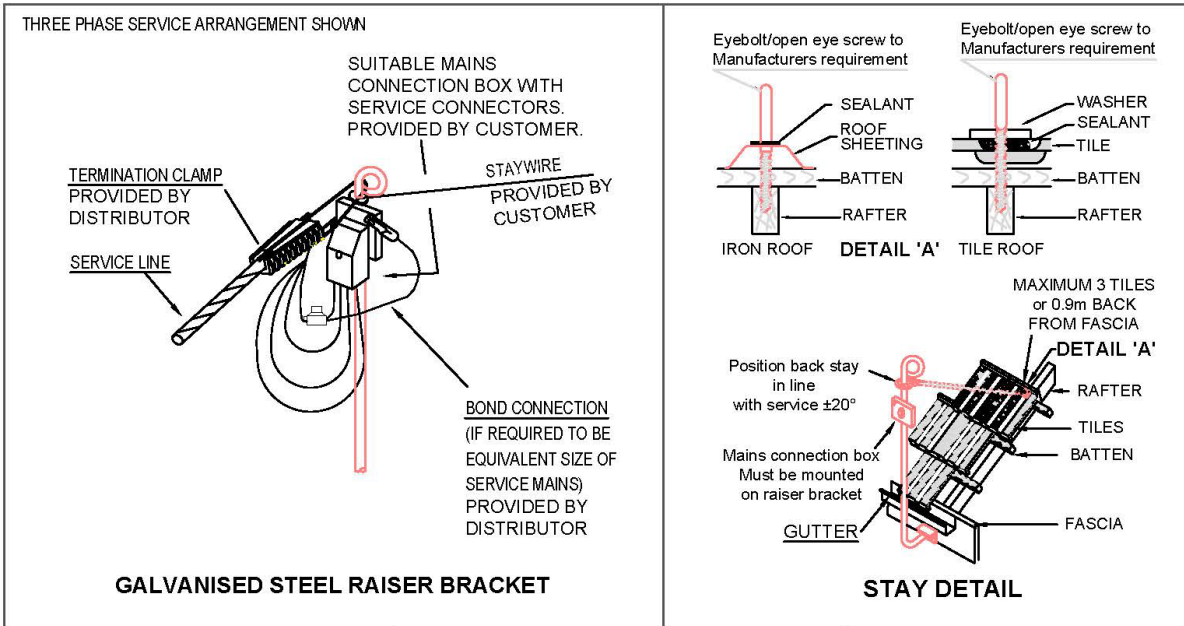

**DIRECTION OF SERVICE - RAISER BRACKET/OPEN EYE SCREW**

**NOTES**

1. Service Line will not be connected where the bracket is installed incorrectly ie. service direction altered without permission/agreement by manufacturer.
2. Manufacturers and Registered Professional Engineer Qld (RPEQ) installation instructions are to be followed in all cases - the detail in this drawing is INFORMATIVE ONLY.
3. Raiser brackets are to be Hot Dipped Galvanised Steel and marked with a suitable 'SWL rating'.
4. Raiser brackets are to be certified by an RPEQ and approved by the distributor.
5. 1kN raiser brackets must not be used to terminate 50/95mm<sup>2</sup> LVABC service. A 3.5kN raiser bracket or an eyebolt/open eye screw installed on a suitable portion of the building or a property pole is to be used.
6. If the service bracket/eyebolt is within 25mm of any structural metal work e.g. guttering or metal fascia of the building, the distributor will bond between the service attachment and the neutral conductor of the service.
7. The customer is to provide suitable means to connect bonding conductor. ie. Earth tag with 12mm hole.

<b>Revision:</b> <b>A</b>	<b>OVERHEAD 25/35mm<sup>2</sup> SERVICE ATTACHMENT TO RAISER BRACKET (1.0kN) - CONNECTION AND BRIDGING DETAILS</b>	<b>QCD06-07</b>
------------------------------	--	-----------------

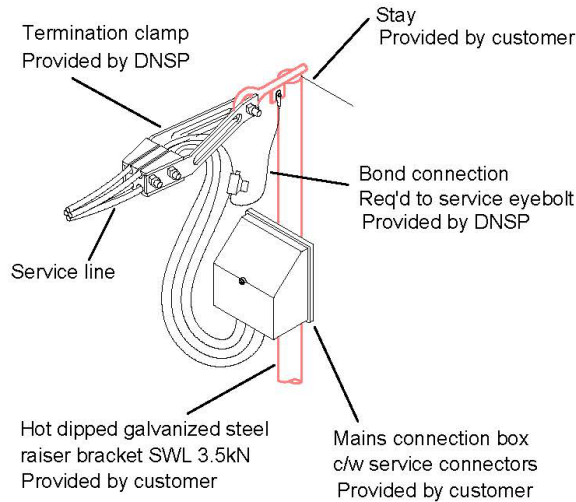

### DIRECTION OF SERVICE - RAISER BRACKET

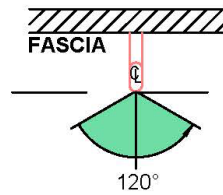

### NOTES

1. Proponent to supply and install suitable mains connection box or non-metallic UV stabilised weatherproof enclosure and suitable lugs. Refer to Clause 6.7.4 for minimum size requirements.
2. Proponent to supply and install lugs to suit current rating of consumer mains and service line. Proponent shall accommodate a 12mm S/S bolt and lug dies where required.
3. Consumer mains to enter through bottom of enclosure.
4. Service Line will not be connected where the bracket is installed incorrectly ie.service direction altered without permission/agreement by manufacturer.
5. Manufacturers and Registered Professional Engineer Qld (RPEQ) installation instructions are to be followed in all cases - the detail in this drawing is INFORMATIVE ONLY.
6. Raiser brackets are to be Hot Dipped Galvanised Steel and marked with a suitable 'SWL rating'.
7. Raiser brackets are to be certified by an RPEQ and approved by the distributor.
8. The bonding of exposed metalwork (eyebolt) must use a conductor size the same as the service line neutral.
9. IPC's must be used to connect all earthing conductors to service line neutral.

<b>Revision:</b>	<b>OVERHEAD 50/95mm<sup>2</sup> SERVICE ATTACHMENT TO RAISER BRACKET (3.5kN) - CONNECTION AND BRIDGING DETAILS</b>	<b>QCD06-08</b>
<b>A</b>		

## 25/35 mm<sup>2</sup> SERVICE LINE CONNECTION WOOD PROPERTY POLE

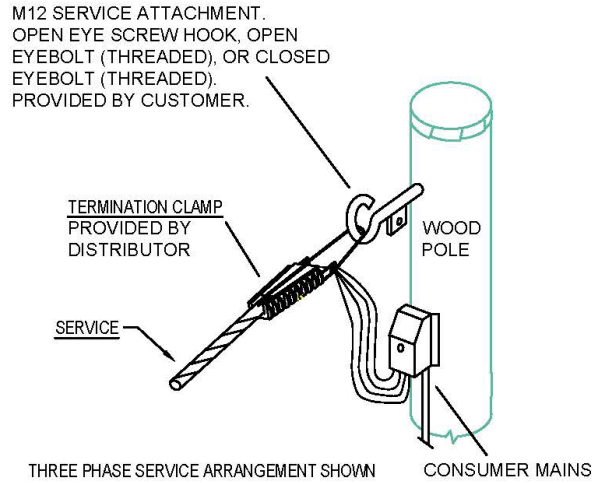

## 25/35 mm<sup>2</sup> SERVICE LINE CONNECTION CONDUCTIVE PROPERTY POLE

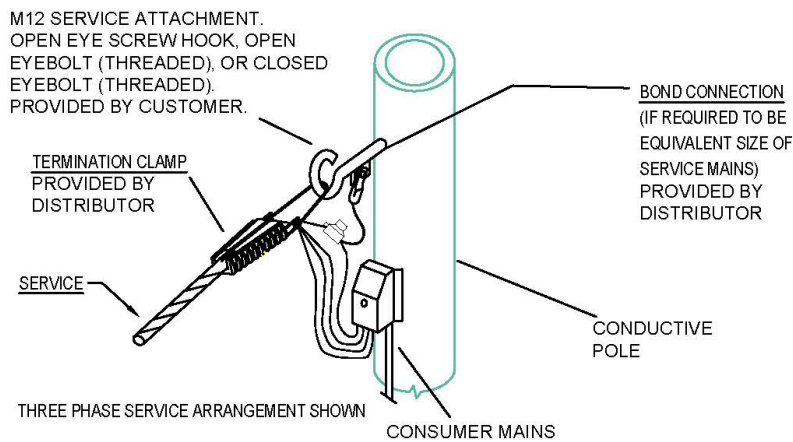

### NOTES

1. Proponent to supply and install suitable mains connection box or non-metallic UV stabilised weatherproof enclosure and suitable lugs. Refer to Clause 6.7.4 for minimum size requirements.
2. Proponent to supply and install lugs to suit current rating of consumer mains and service line. Proponent shall accommodate a 12mm S/S bolt and lug dies where required.
3. Consumer mains to enter through bottom of enclosure.
4. The bonding of exposed metalwork (eyebolt) must use a conductor size the same as the service line neutral.
5. IPC's must be used to connect all earthing conductors to service line neutral.

Revision:

**A**

**OVERHEAD 25/35mm<sup>2</sup> SERVICE ATTACHMENT TO PROPERTY  
POLE (1.0kN) - CONNECTION AND BRIDGING DETAILS**

**QCD06-09**

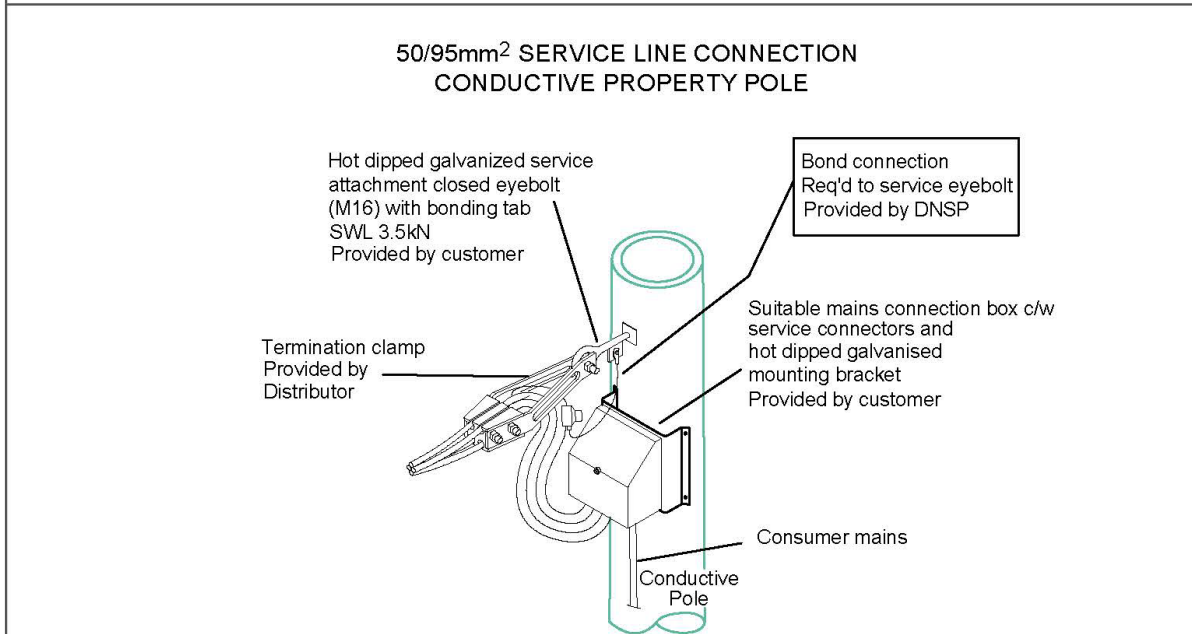
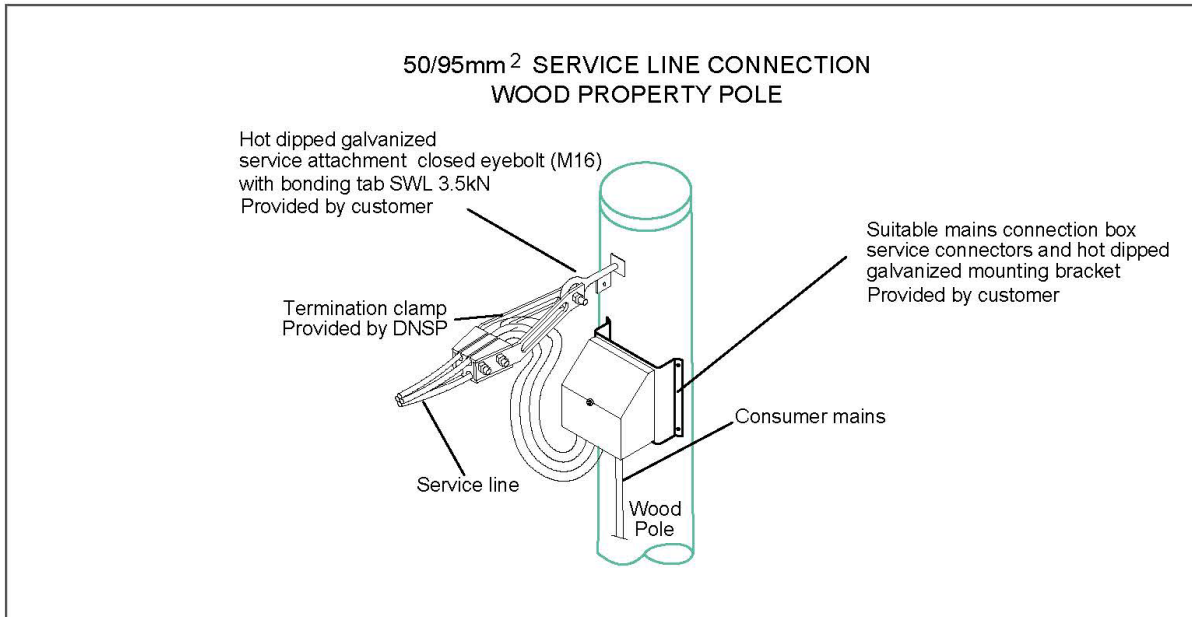

**NOTES**

1. Proponent to supply and install suitable mains connection box or non-metallic UV stabilised weatherproof enclosure and suitable lugs. Refer to Clause 6.7.4 for minimum size requirements.
2. Proponent to supply and install lugs to suit current rating of consumer mains and service line. Proponent shall accommodate a 12mm S/S bolt and lug dies where required.
3. Consumer mains to enter through bottom of enclosure.
4. The bonding of exposed metalwork (eyebolt) must use a conductor size the same as the service line neutral.
5. IPC's must be used to connect all earthing conductors to service line neutral.

Revision: <b>A</b>	<b>OVERHEAD 50/95mm<sup>2</sup> SERVICE ATTACHMENT TO PROPERTY POLE (3.5kN) - CONNECTION AND BRIDGING DETAILS</b>	<b>QCD06-10</b>
-----------------------	---	-----------------

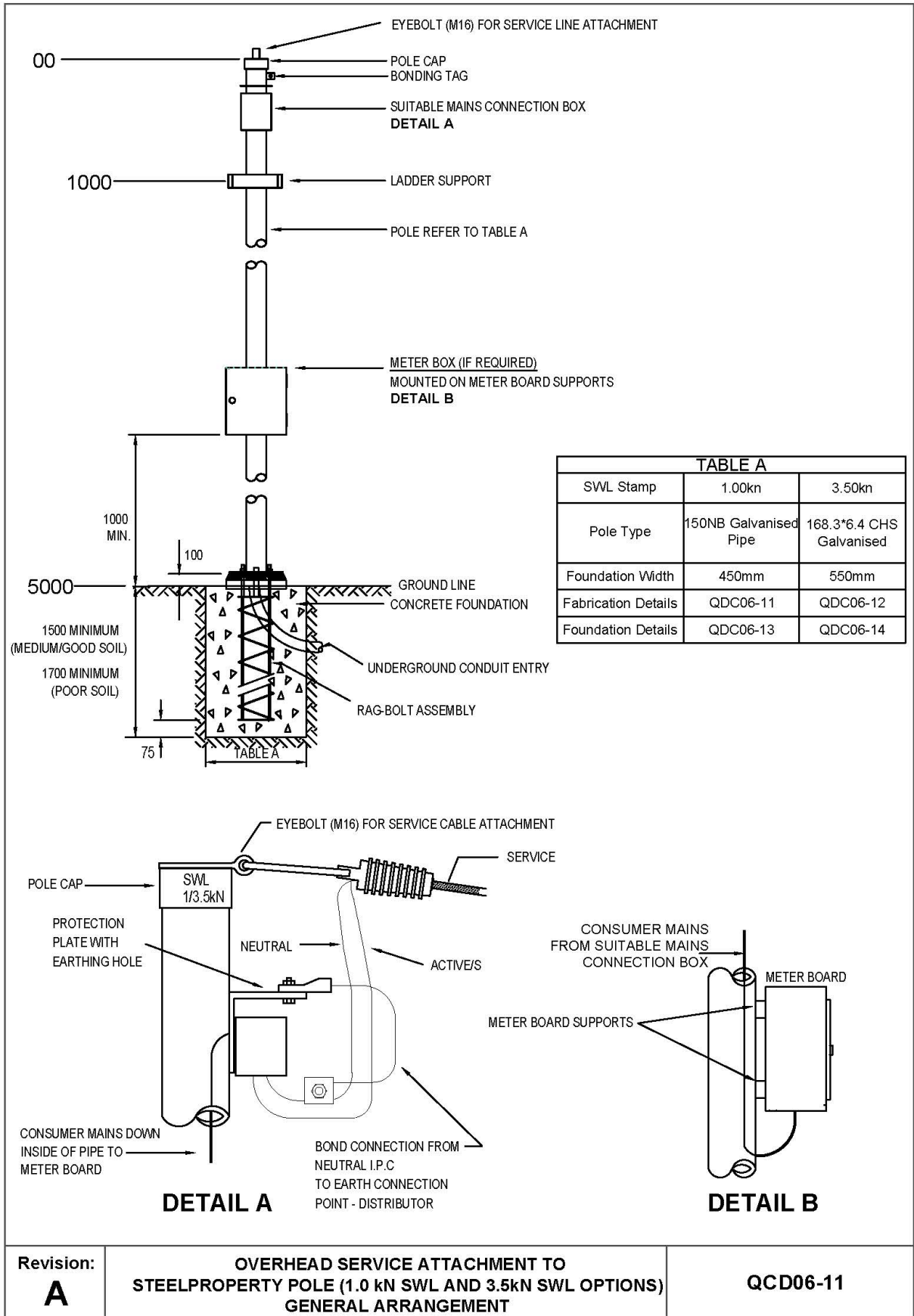



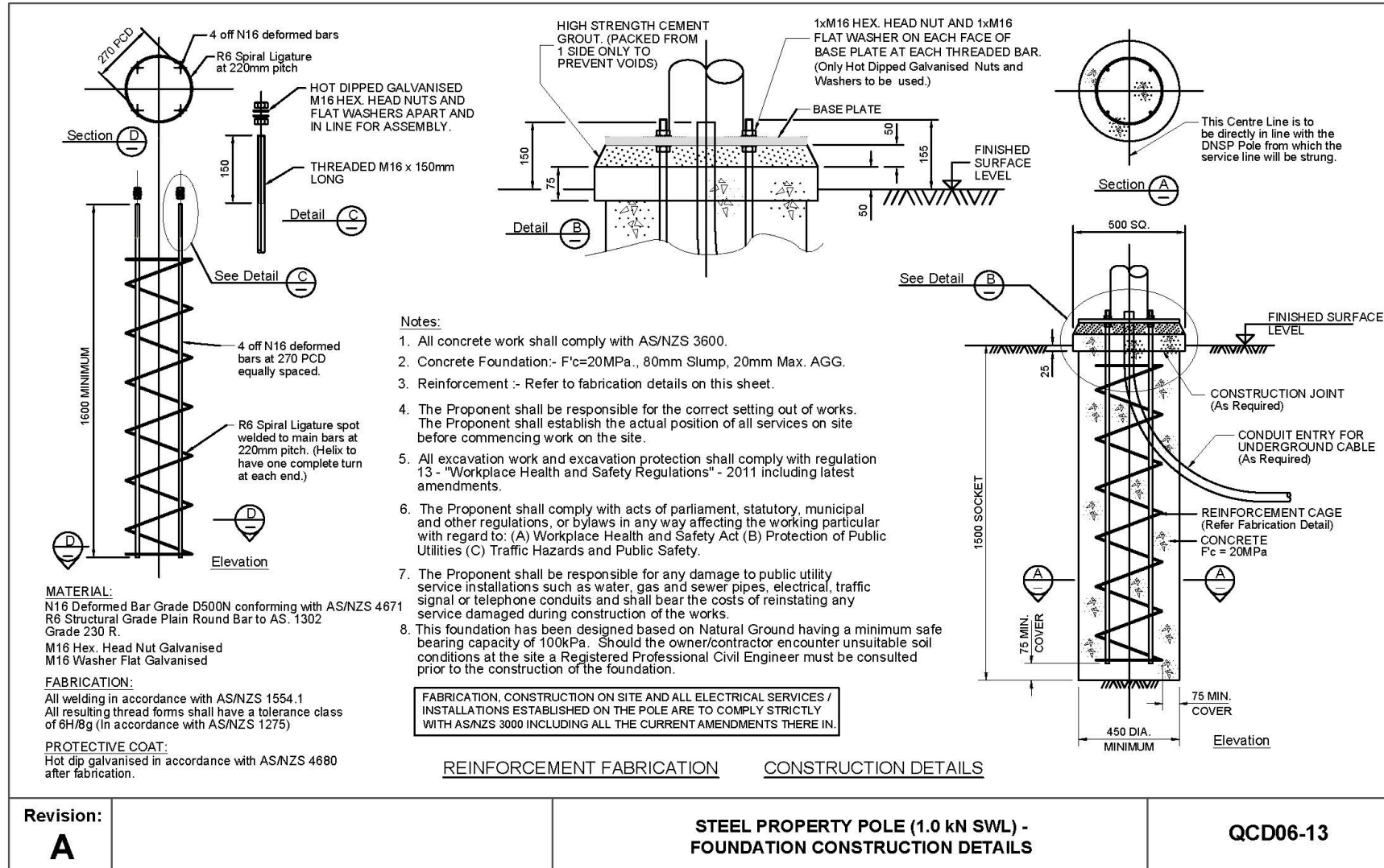

# Queensland Electricity Connection Manual

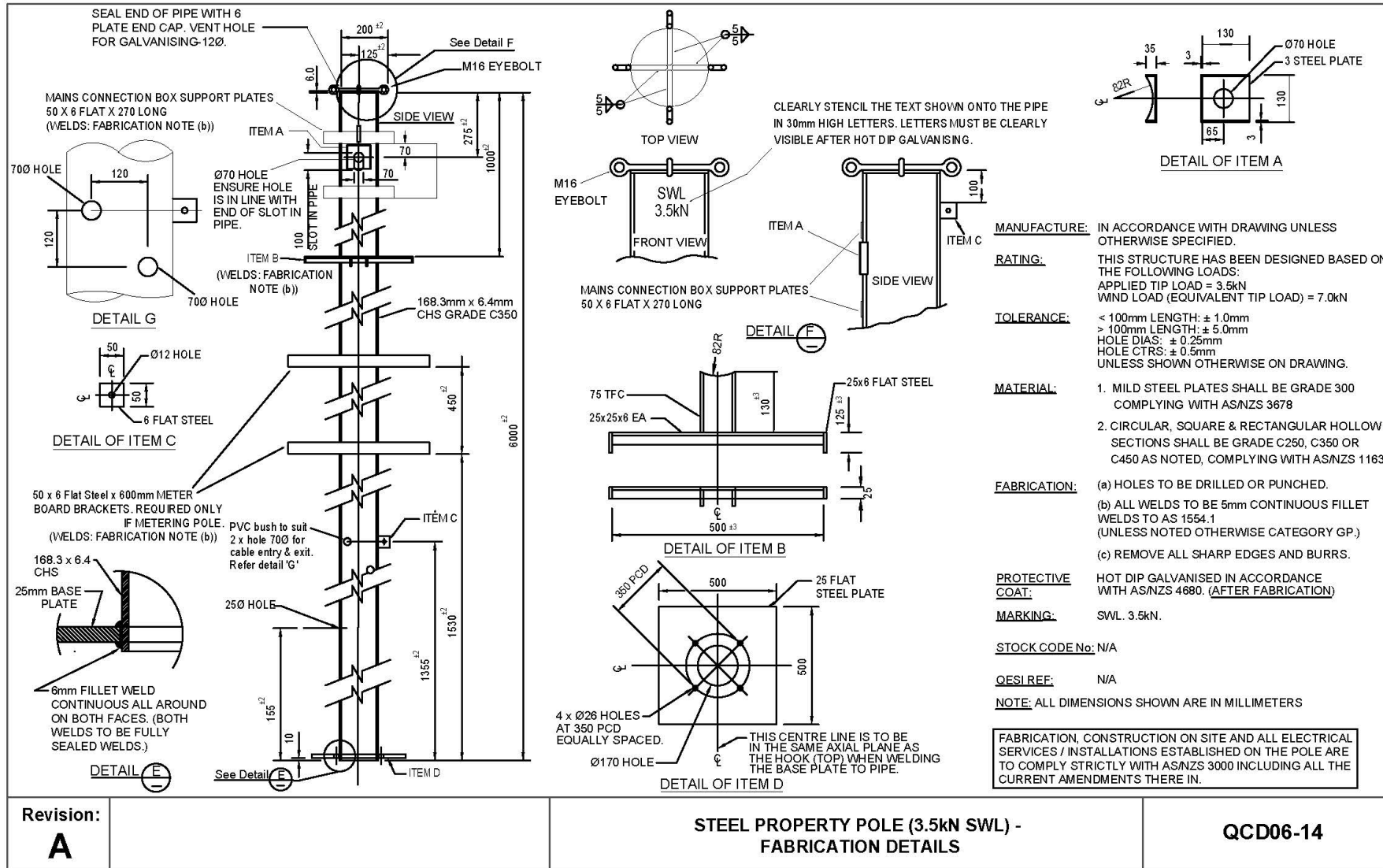

Revision:  
**A**

**STEEL PROPERTY POLE (3.5kN SWL) - FABRICATION DETAILS**

**QCD06-14**

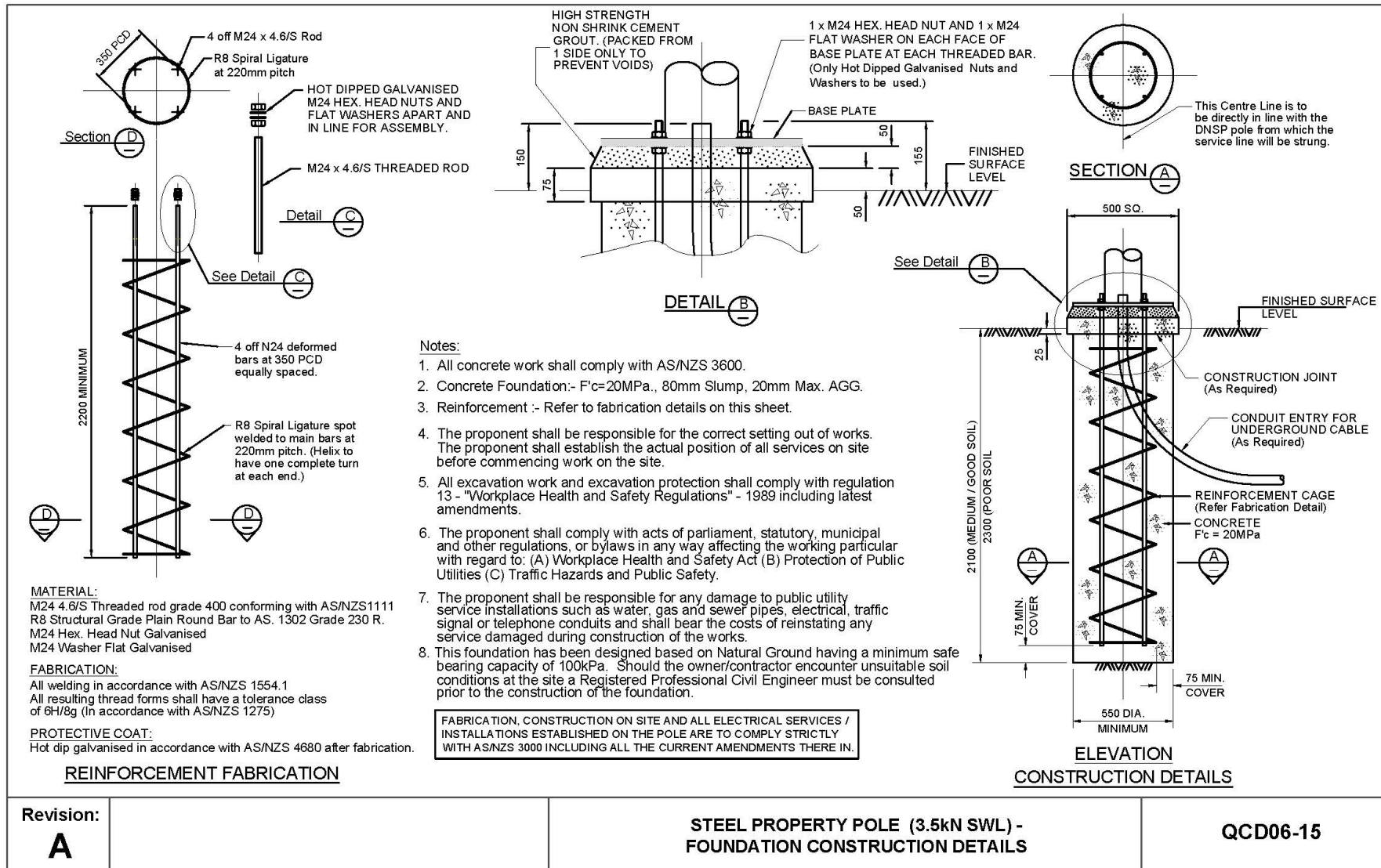

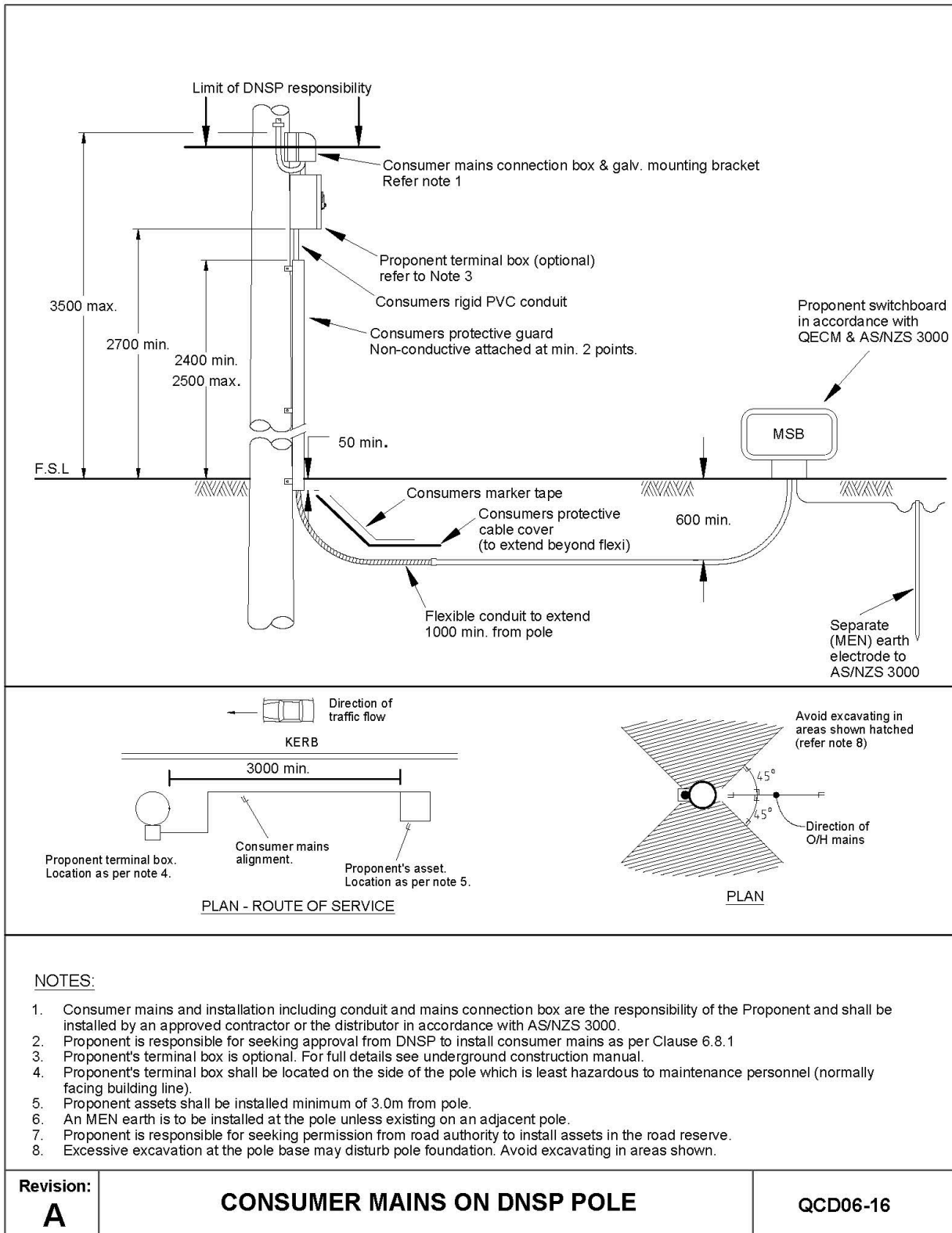

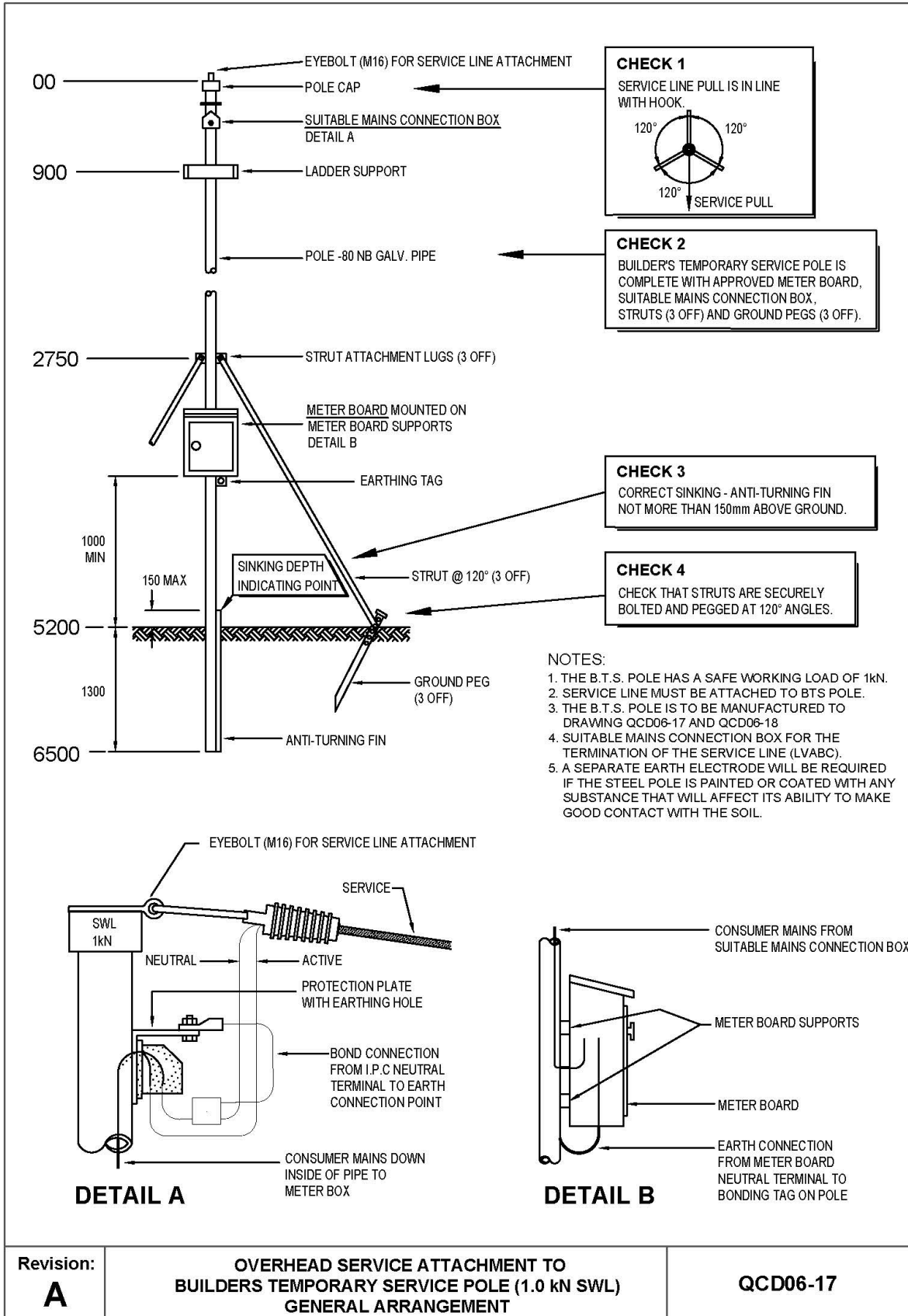

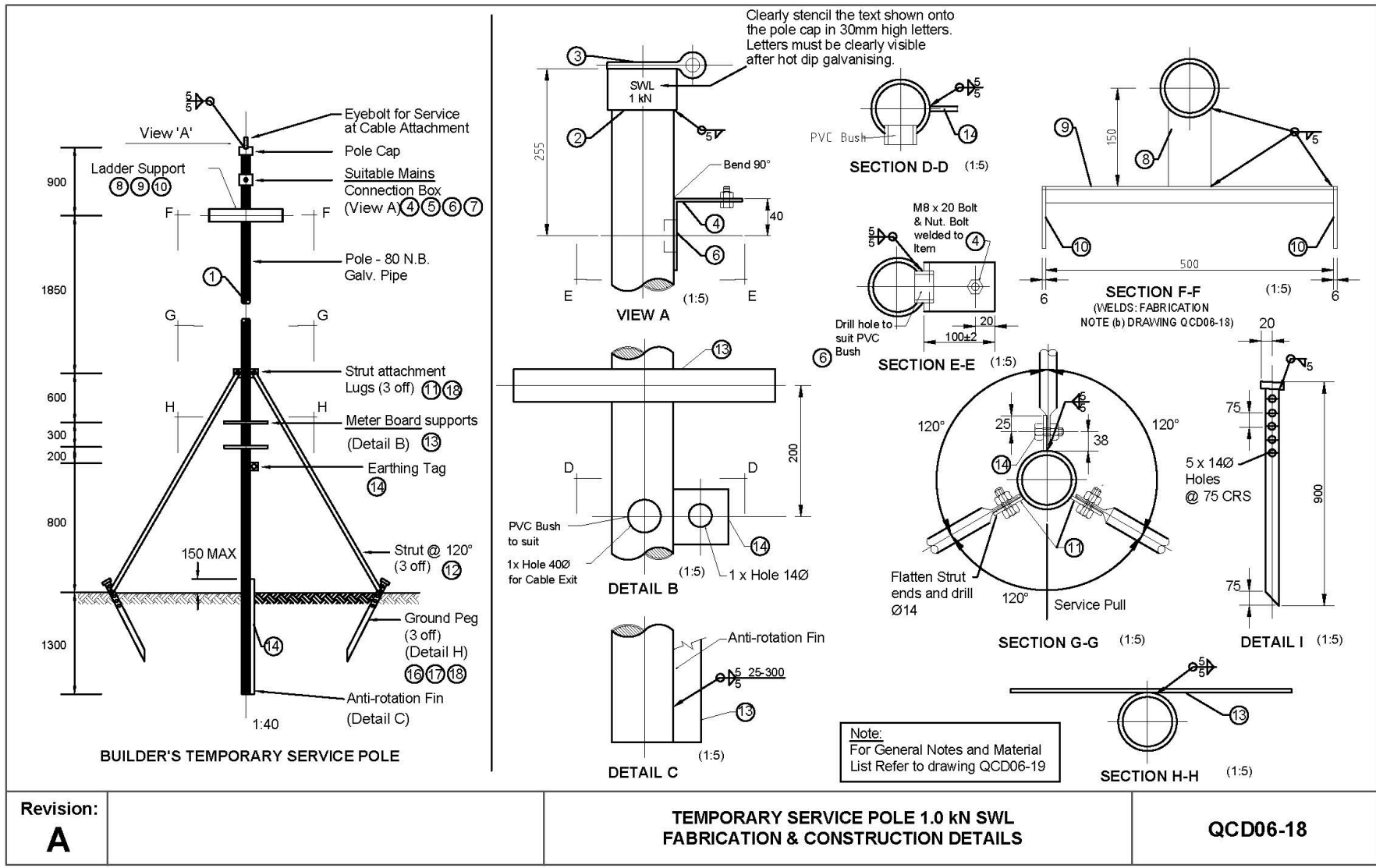

Revision: <b>A</b>	<b>TEMPORARY SERVICE POLE 1.0 kN SWL          FABRICATION &amp; CONSTRUCTION DETAILS</b>	<b>QCD06-18</b>
-----------------------	--	-----------------

# Queensland Electricity Connection Manual

## MATERIAL LIST

Item	Description	No. Off	Description
①	Pole	1	80 N.B. x 4.0 Thk. x 6500Lg. Std. Galv. Pipe
②	Cap or Disc	1	To suit 80N.B. Pipe
③	Service Attachment Ring	1	M16 Eyebolt
④	Mains connection Box Baseplate	1	FL 75 3 x 200 Lg. Bent 90° as shown on QCD06-17
⑤	Mains Connection Box	1	3 terminal clipsal Cat. No. IP23
⑥	Threaded PVC Bush	1	To suit MCB
⑦	Screw (Drill & tap item-4 to suit MCB)	2	M5 x 12Lg. S/S Grade 304
⑧	Ladder Support Bracket	1	Taper-flange Channel
⑨	Ladder Support Member	1	L 25x25x6x500Lg
⑩	Ladder Stops	2	L 25x6x125Lg
⑪	Strut Attachment Lug	3	FL 75 x 10 x 75Lg.
⑫	Strut Members	3	25N.B. x 3150Lg. Std. Galv. Pipe
⑬	Meter Box Supports	2	FL 50 x 6 x 400Lg.
⑭	Earthing Lug	1	FL 50 x 6 x 50Lg.
⑮	Stabilising fin	1	FL 50 x 6 x 1450Lg.
⑯	Peg	3	L38 x 38 x 6 x 900Lg.
⑰	Striking Plate	3	FL 50 x 10 x 50 Lg.
⑱	Bolt & Nut	6	M12 x 40 Lg. Hex. Galv.

## SPECIFICATIONS

- RATING :** This structure has been designed based on the following loads:  
Applied tip load - 1.0 kN.
- TOLERANCE :** All tolerances to be  $\pm 5.0$
- MATERIAL :** Structural steel in accordance with AS/NZS 4100.
- MATERIAL :** Structural Steel in accordance with AS/NZS 3678, AS/NZS 3679.1 Grade 250. See material list for details.
- FABRICATION :** (a) Holes to be drilled or punched undersize & reamed.  
(b) Welding to be in accordance with AS/NZS 1554.1  
(c) All sharp edges and burrs to be removed.
- PROTECTIVE COAT :** All steelwork to be effectively corrosion protected.
- MARKING :** SWL 1 kN

NOTES:  
1. FOR CONSTRUCTION AND DETAILS REFER TO DRAWING QCD06-18  
2. NB = NOMINAL BORE

Revision:

**A**

**TEMPORARY SERVICE POLE 1.0 kN SWL  
FABRICATION AND CONSTRUCTION DETAILS**

**QCD06-19**

## A.3: Section 7 – Underground connection and supply requirement drawings

### SAMPLE ONLY - DESIGN UNDER DEVELOPMENT

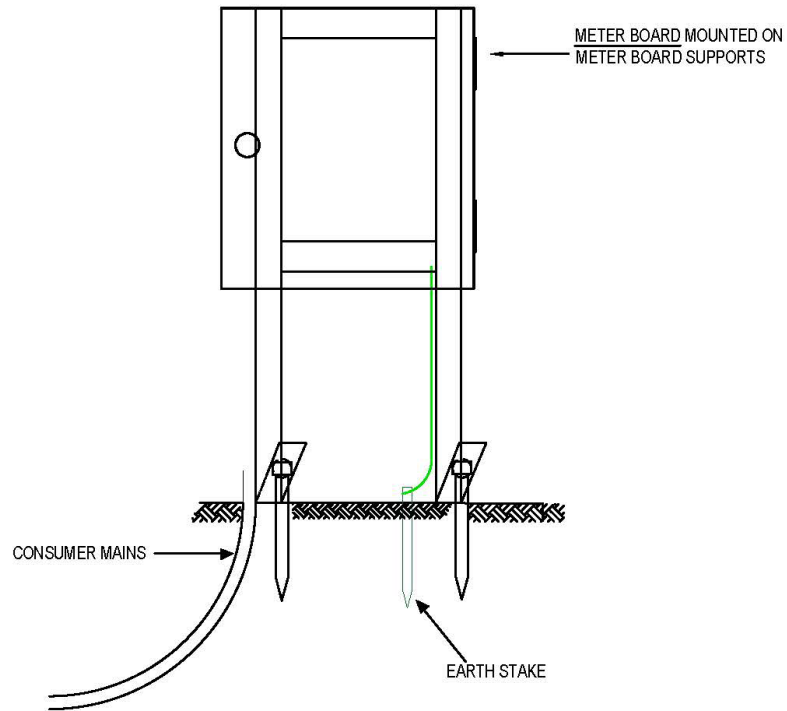

NOTES:

1. STAR PICKETS ARE NOT SUITABLE FOR INTERIM STRUCTURE TO BE CONNECTED.
2. INTERIM STRUCTURE MUST BE SECURELY FASTENED.
3. REFER TO METER BOARD REQUIREMENTS OUTLINED IN CHAPTER 10

Revision: <b>A</b>	<b>UNDERGROUND CONNECTION TO AN INTERIM STRUCTURE DURING CONSTRUCTION GENERAL ARRANGEMENT</b>	<b>QCD07-01</b>
-----------------------	---	-----------------

## A.4: Section 8 – Electrical installation requirements

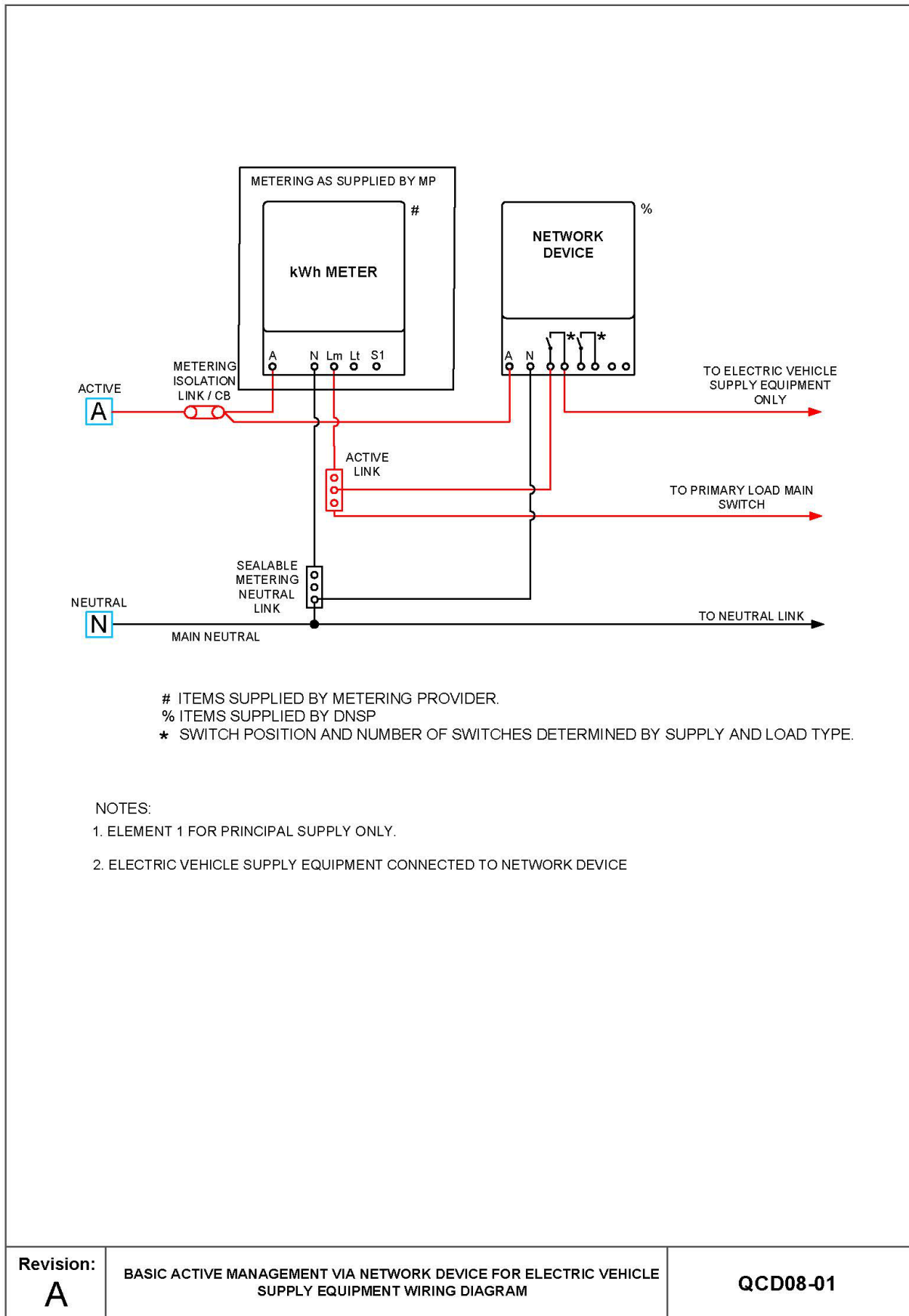



# Queensland Electricity Connection Manual

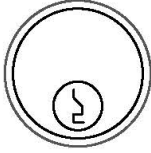
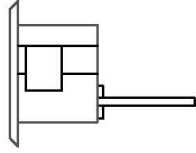
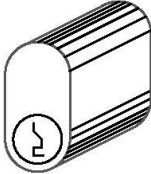
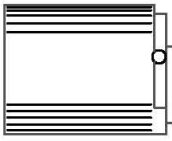
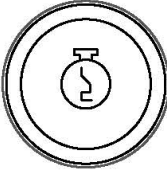
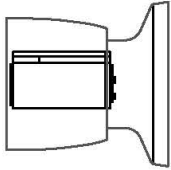

**\*\*Placeholder for Basic active management via *Network Device* for electric vehicle supply equipment - three-phase & - three-phase with contactor\*\***

## A.5: Section 9 – Network device and metering general requirements

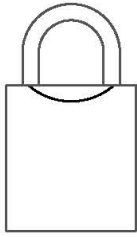
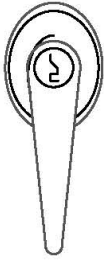
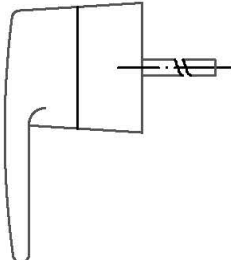
RIM LOCK CYLINDER		
		<p>TYPE <b>201 CYL</b> FOR USE IN NIGHTLATCH/STREAMLATCH/DEADLATCH TYPE LOCKSETS. (CYLINDER ONLY PROVIDED.)</p>
MORTICE LOCK CYLINDER		
		<p>TYPE <b>570 CYL</b> FOR USE IN CYLINDER MORTICE LOCKS AND LATCHES. (CYLINDER ONLY PROVIDED.)</p>
KEY - IN - KNOB CYLINDER		
		<p>TYPE <b>530 CYL</b> FOR USE IN KEY-IN-KNOB AND KEY-IN-LEVER LOCKSETS. (CYLINDER ONLY PROVIDED.)</p>
BRASS PADLOCK		
		<p>TYPE <b>234</b> FOR USE IN ERGO ENERGY TYPE <b>234/SS</b> FOR USE IN ENERGEX</p> <p>234/45/119 - 19mm SHACKLE 234/45/138 - 38mm SHACKLE 234/45/148 - 48mm SHACKLE 234/45/190 - 90mm SHACKLE</p> <p>(COMPLETE LOCK PROVIDED.)</p>
METER CUBICLE LOCK		
		<p>TYPE '<b>L</b>' HANDLE OR '<b>T</b>' HANDLE TO BE USED AS A METER CUBICLE LOCK. (COMPLETE LOCK PROVIDED.)</p> <p>NOTES: 1. USE 'EX' PREFIX TO INDICATE ENERGEX METERING KEY SYSTEM EG ENERGEX RIM LOCK CYLINDER USE TYPE EX201 CYL. 2. A LIST OF APPROVED LOCKSMITHS IS AVAILABLE ON THE DISTRIBUTORS WEBSITE - SEE CONTACTS PAGE FOR DETAILS.</p>
Revision: <b>A</b>	<b>MASTER KEYED UTILITY ACCESS LOCK DETAILS</b>	<b>QCD09-01</b>

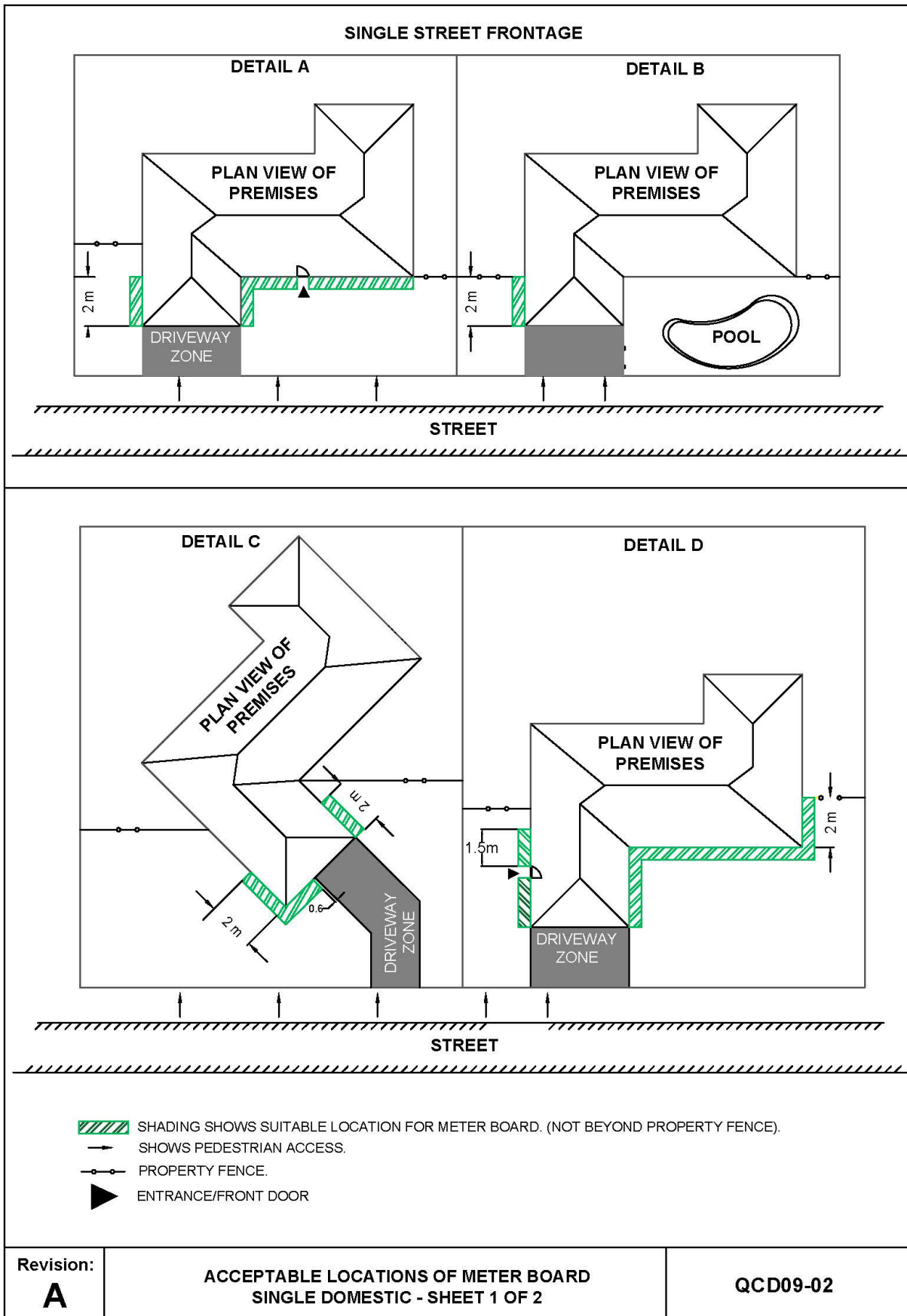

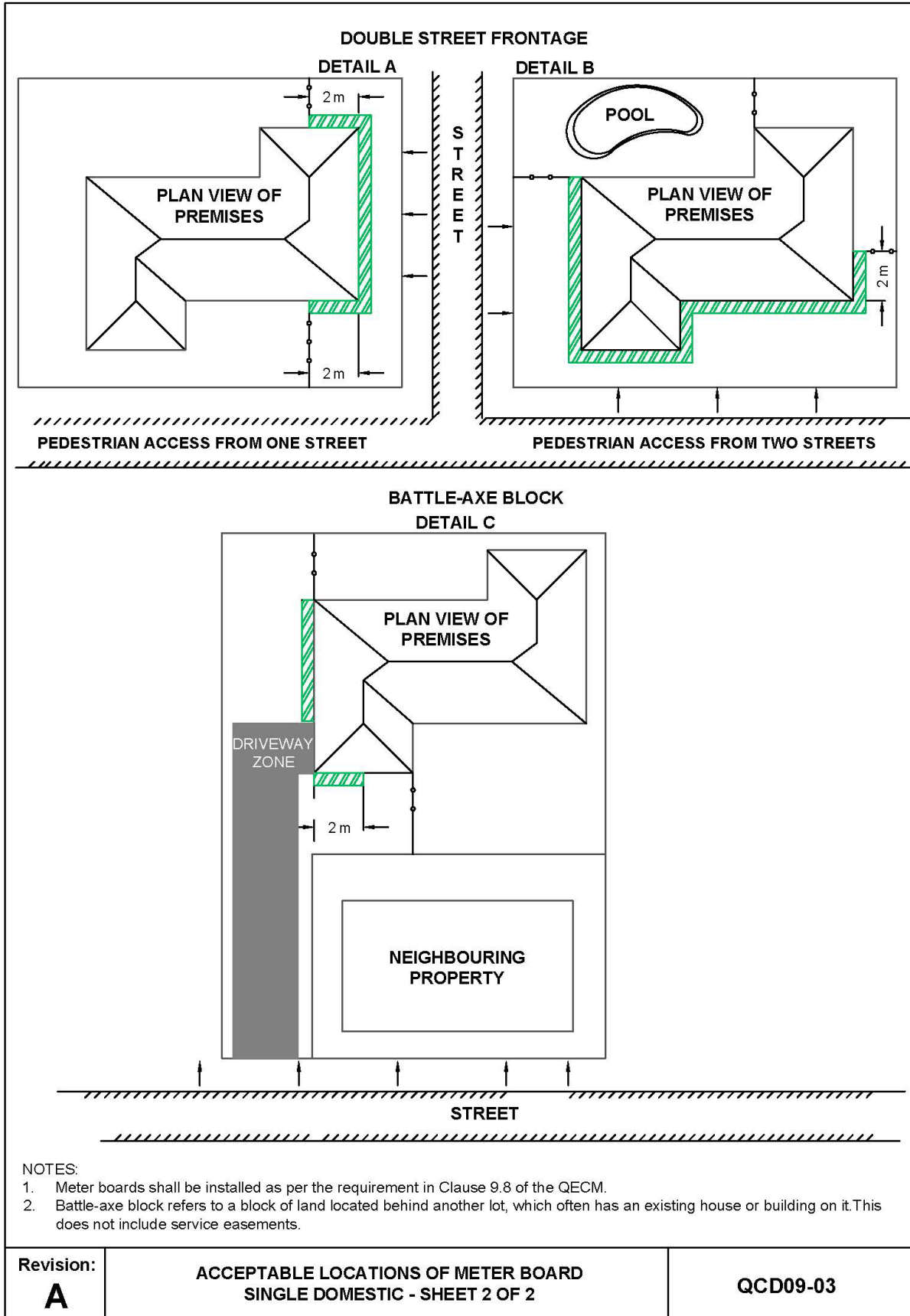

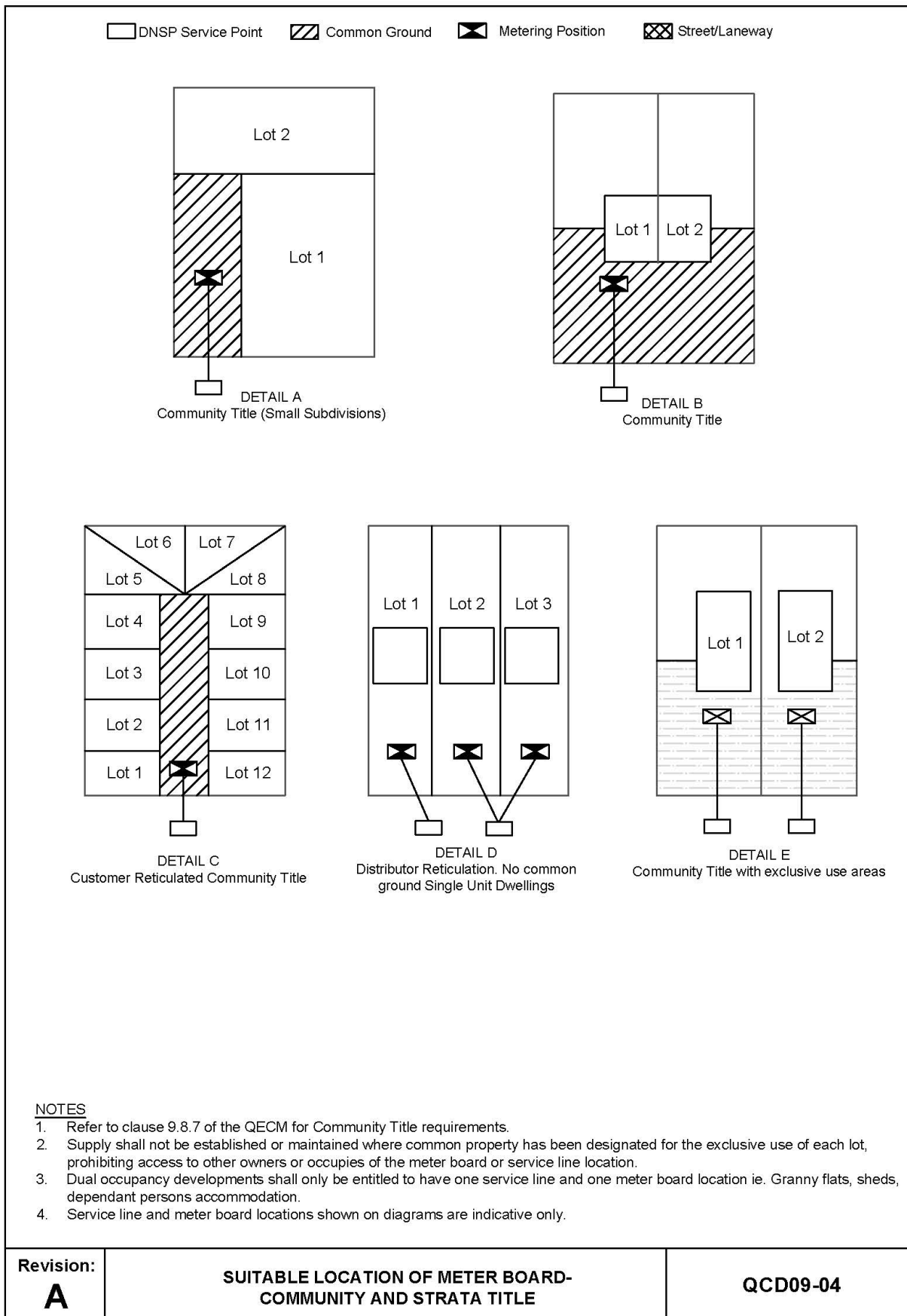

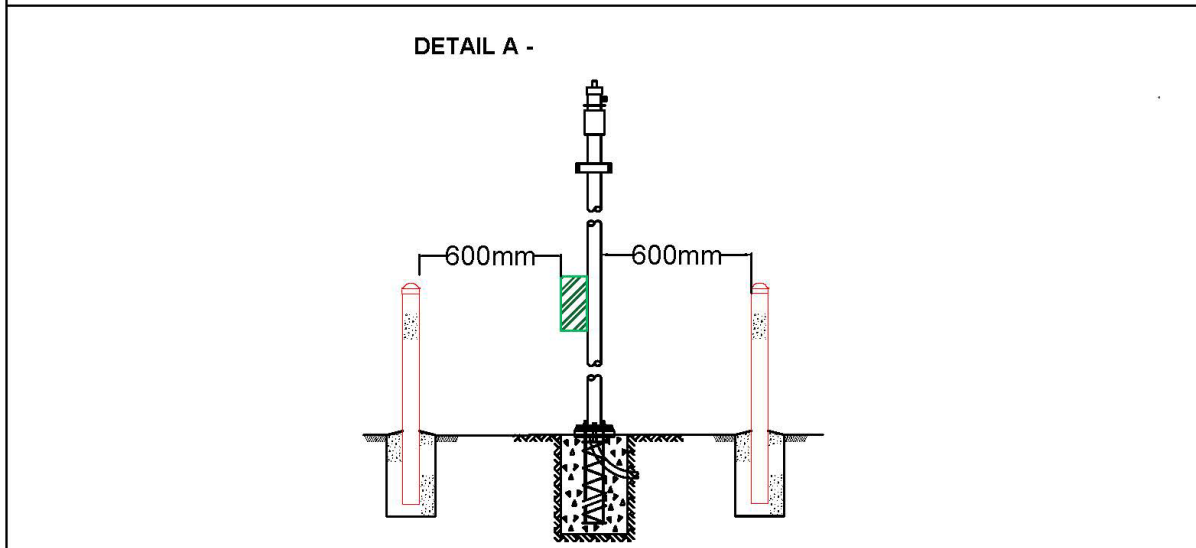
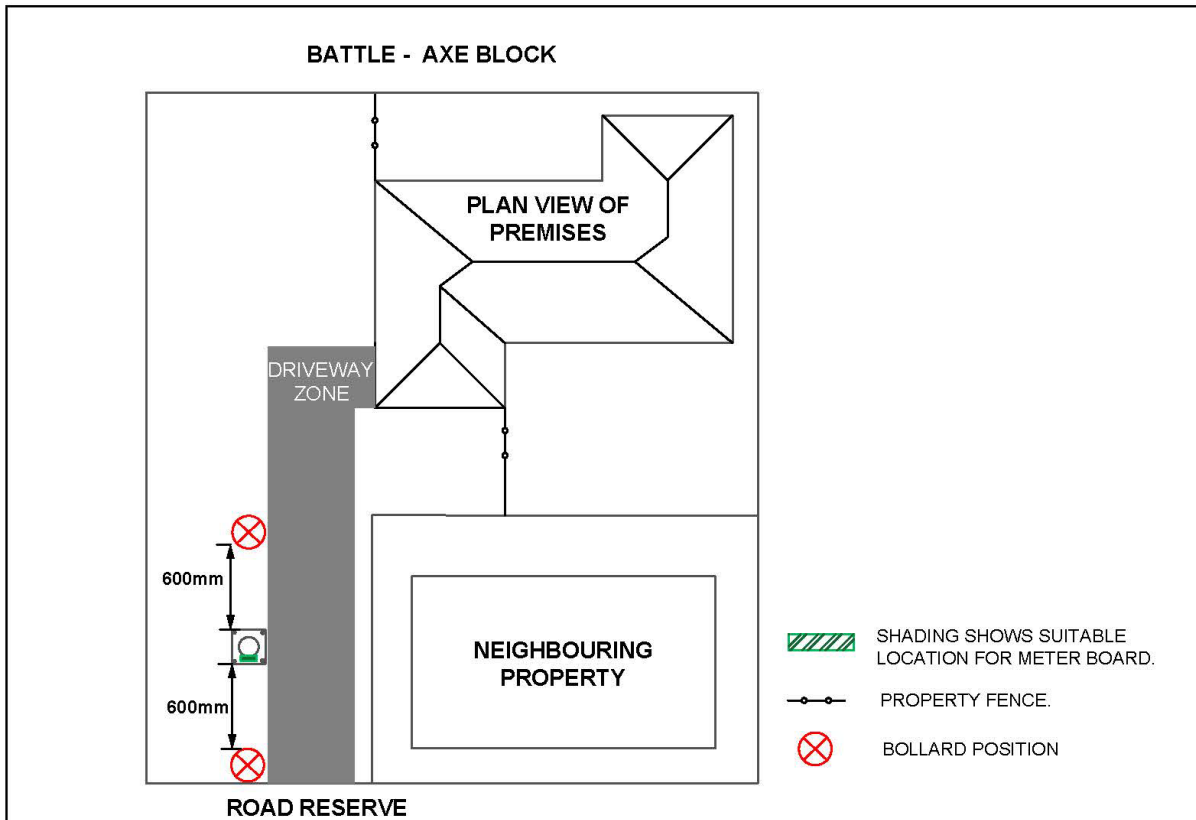

**NOTES:**

1. Meter boards shall be installed as per the requirement in Clause 9.8 of the QECM. Where the meter board position is located on the property pole it must not be located in an unsuitable position.
2. A minimum 600mm clearance is required between the bollard and the meter board when installed adjacent to trafficable area. Bollard position indicated by red X
3. Battle-axe block refers to a block of land located behind another lot, which often has an existing house or building on it. This does not include service and access easements.

Revision: <b>A</b>	<b>BOLLARD POSITIONS FOR METER BOARD LOCATED ON PROPERTY POLE</b>	<b>QCD09-05</b>
-----------------------	---	-----------------

## A.6: Section 10 – LV connected network device and metering requirements

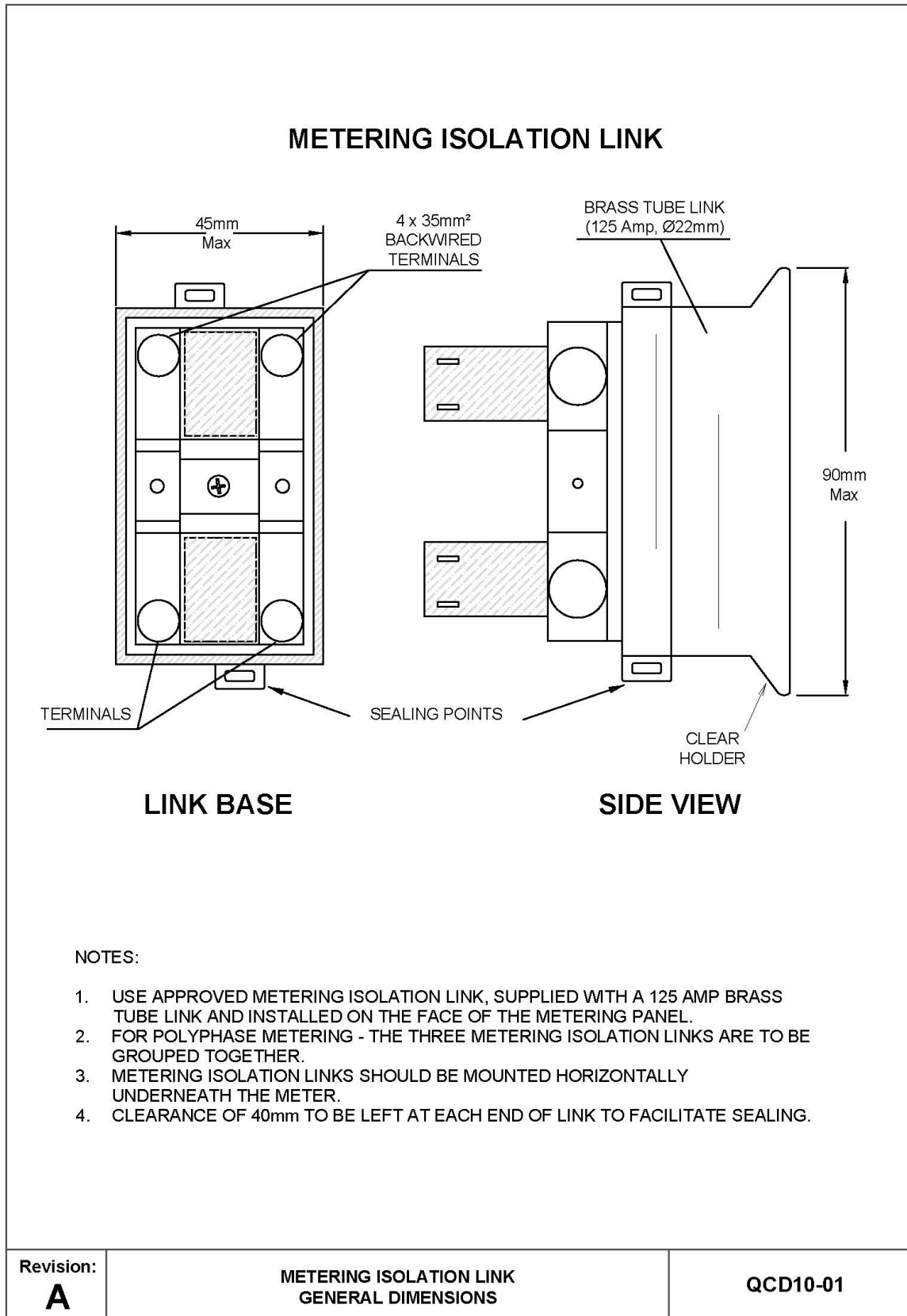

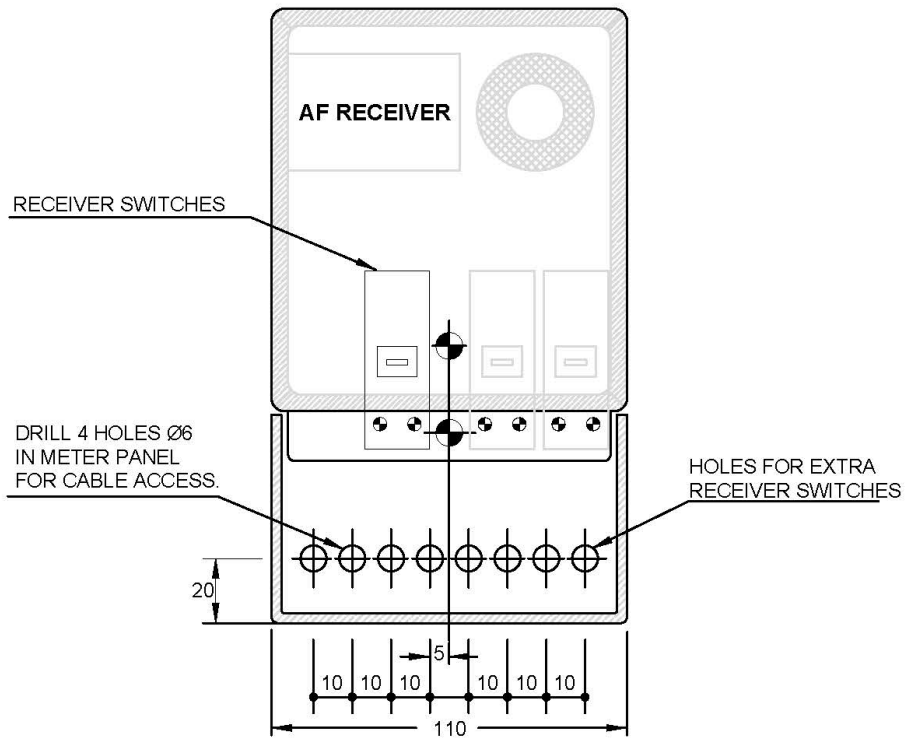

Revision:

**A**

**AF RECEIVER  
DRILLING DETAILS FOR CABLE ACCESS**

**QCD10-02**

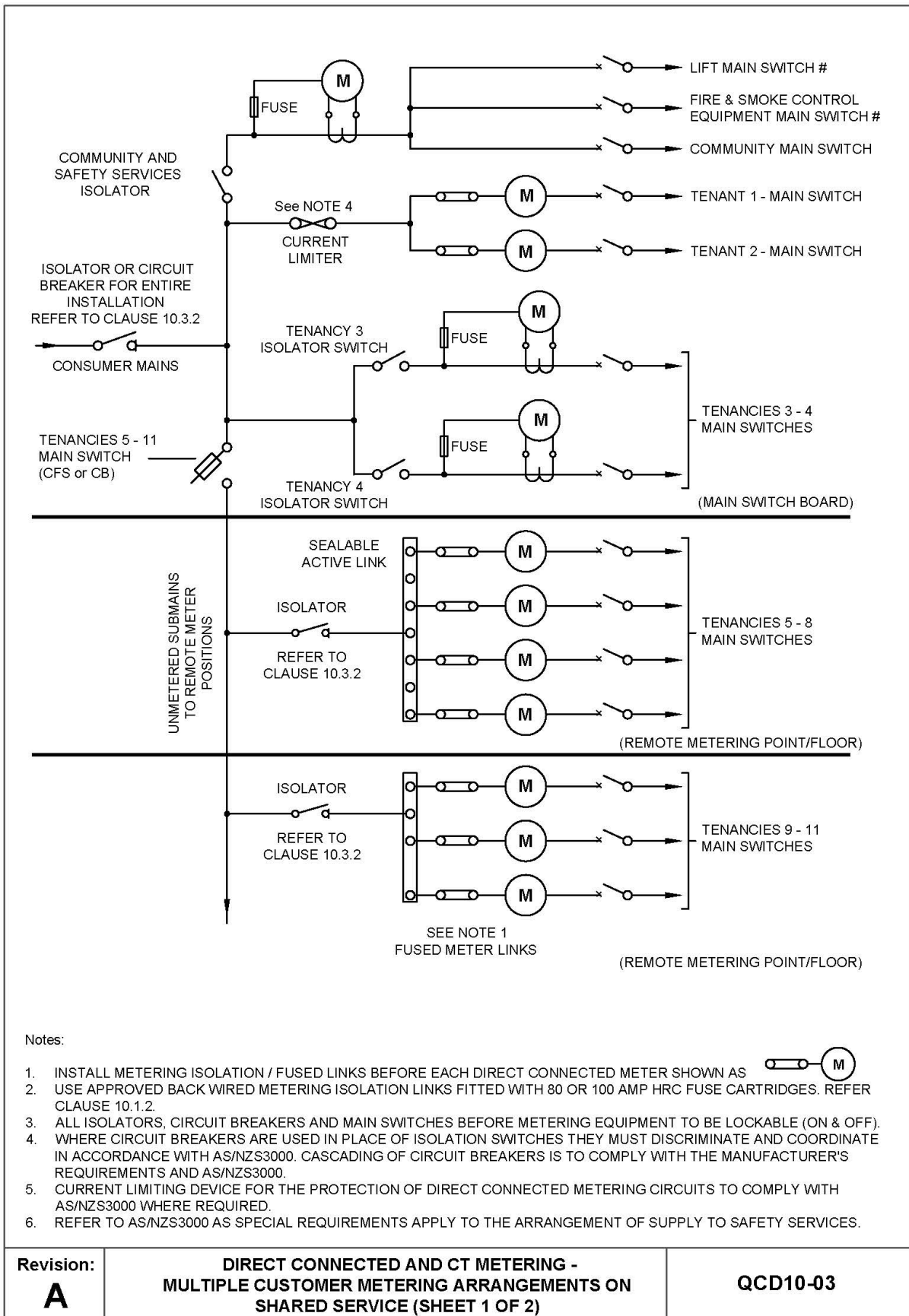

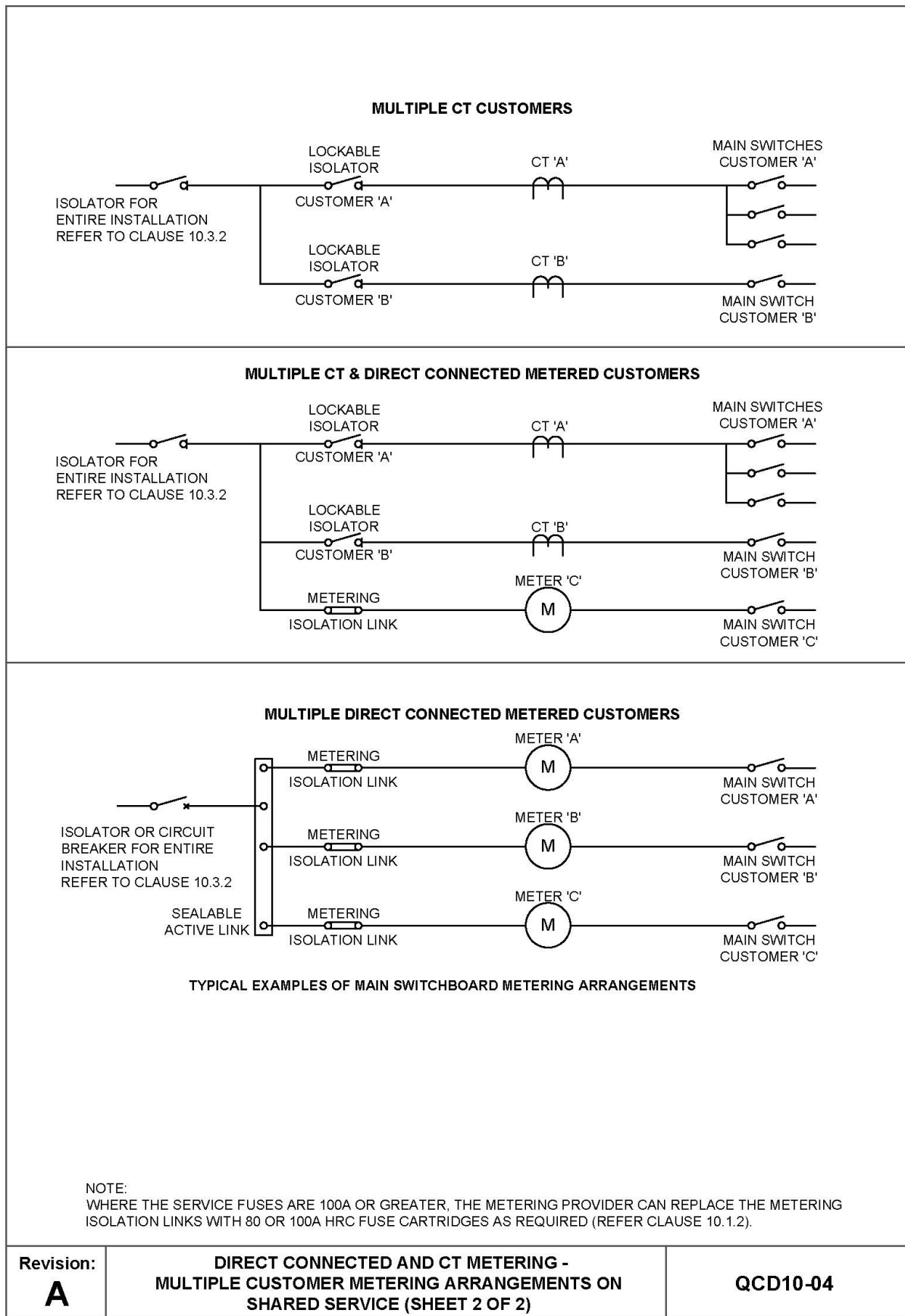

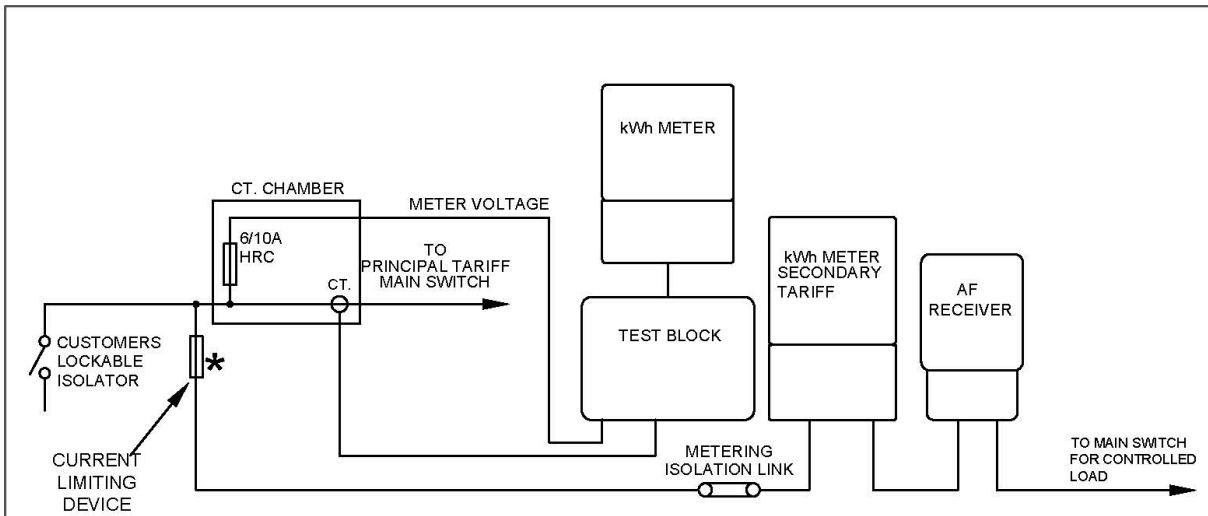

**NOTES:**

1. \* CURRENT LIMITING DEVICES FOR THE PROTECTION OF DIRECT CURRENT METERING CIRCUITS SHALL COMPLY WITH AS/NZS 3000 AND SHALL NOT BE RATED GREATER THAN A 100A HRC FUSE OR EQUIVALENT.
2. THE METERING PROVIDER MAY USE AN INTEGRATED METER IN PLACE OF THE SEPARATE CONTROLLED LOAD METER AND AF RECEIVER.

TYPICAL LAYOUT OF A CURRENT TRANSFORMER METERING INSTALLATION INCORPORATING A DIRECT CONNECTED METER FOR A SEPARATE CONTROLLED SUPPLY.

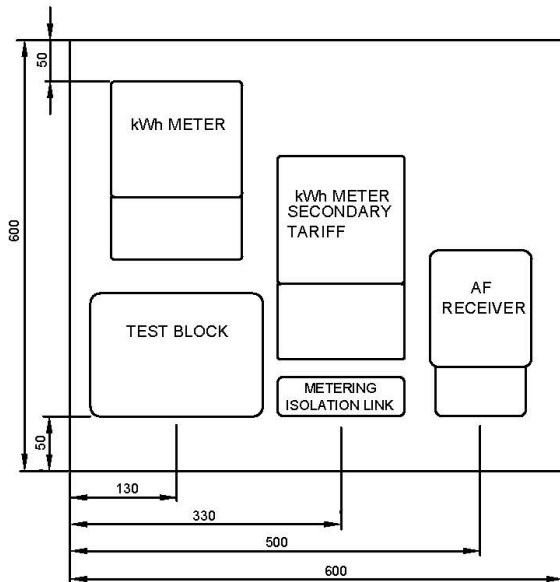

TYPICAL LAYOUT FOR SINGLE NMI CT. METERING

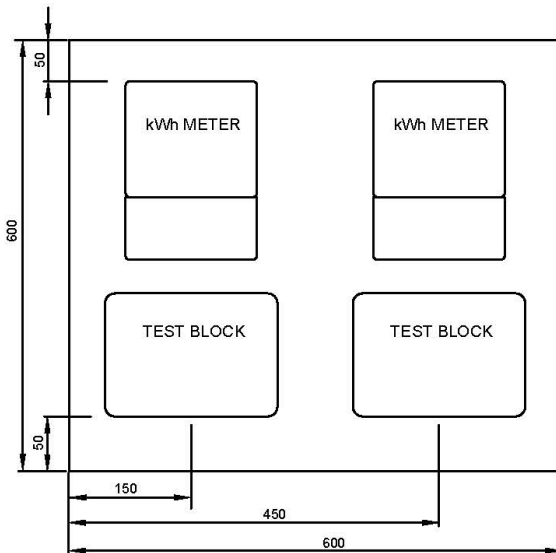

<b>Revision:</b> <b>A</b>	<b>CT METERING - TYPICAL METER PANEL LAYOUT AND ARRANGEMENT</b>	<b>QCD10-05</b>
------------------------------	---	-----------------

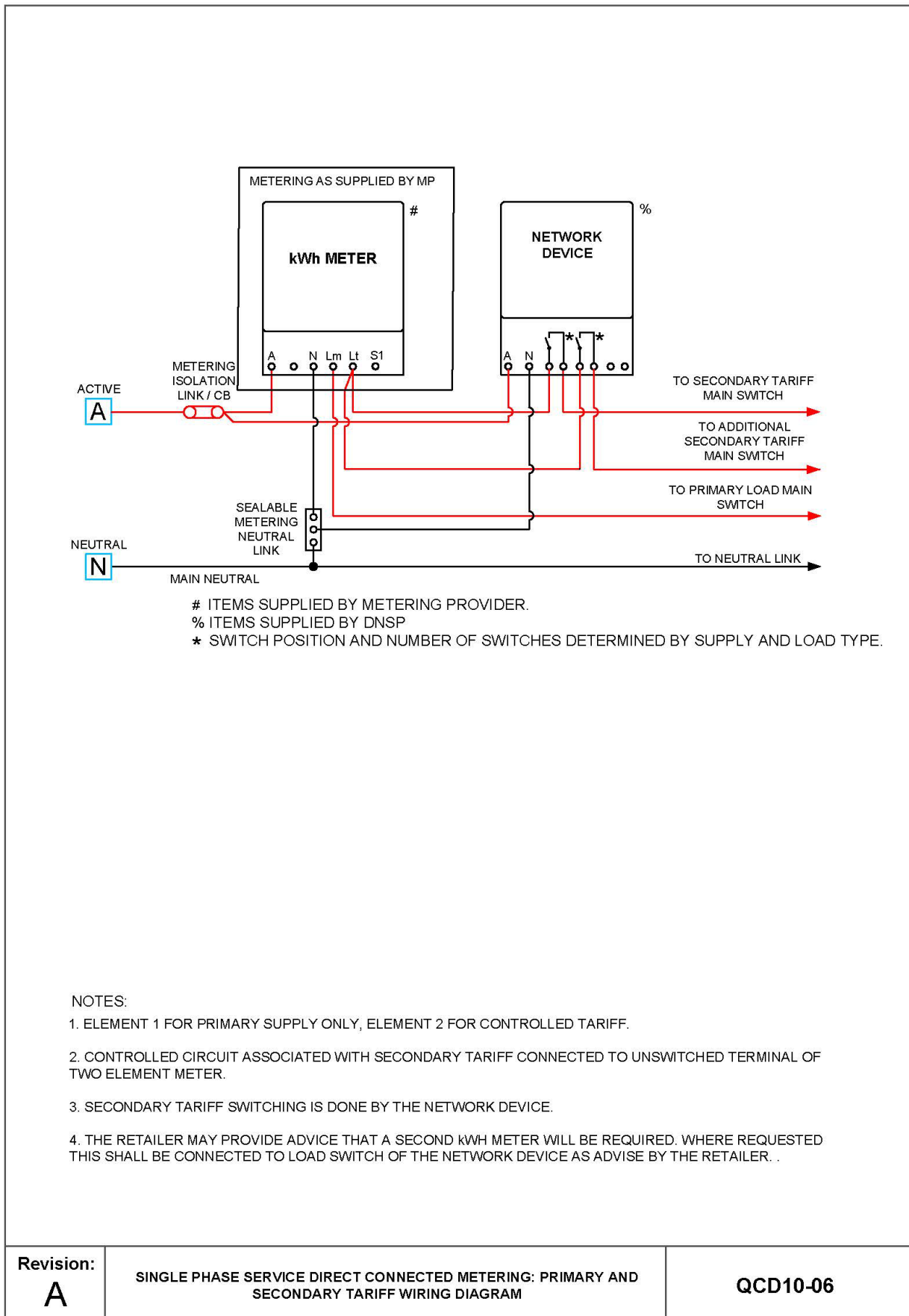

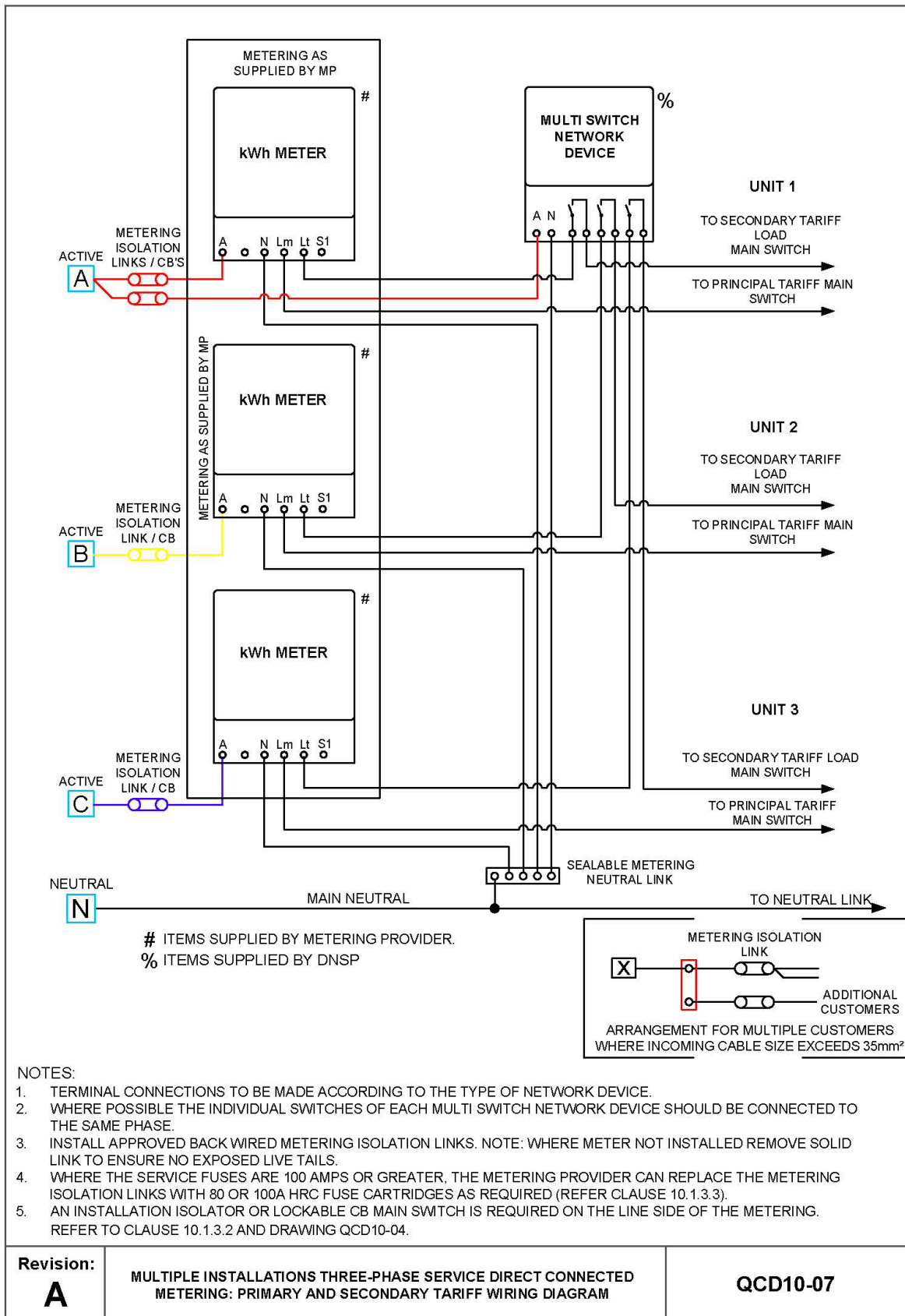

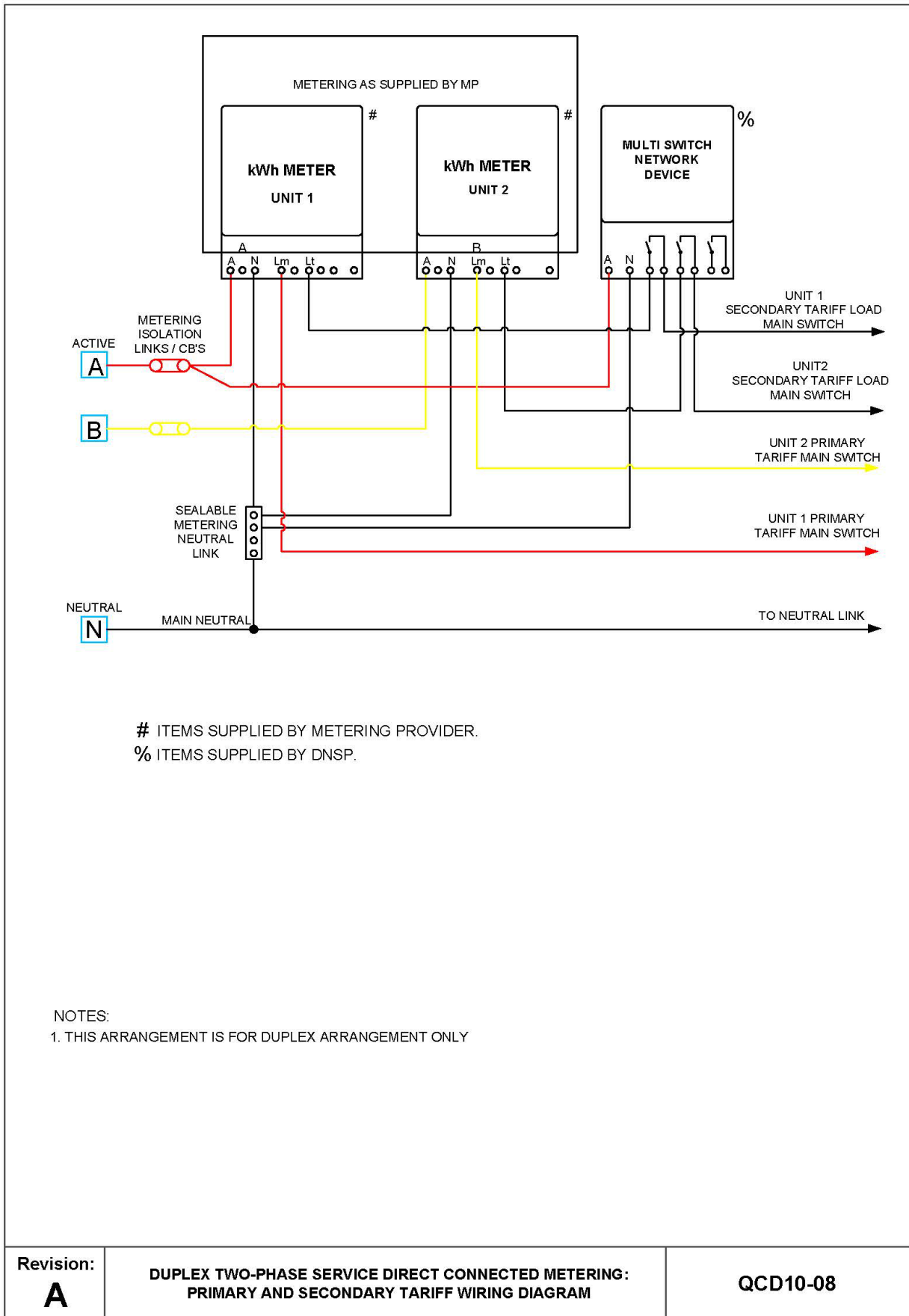

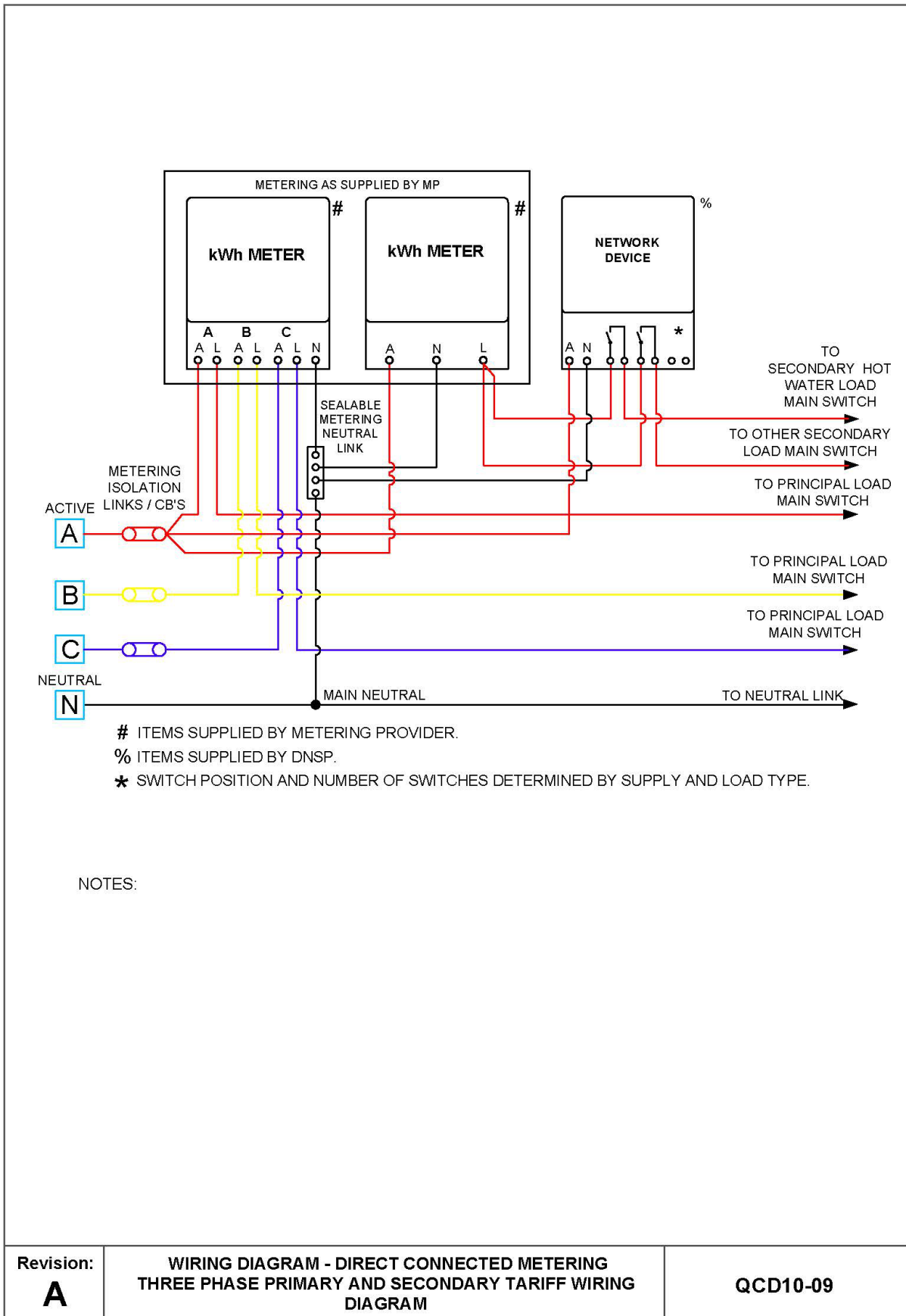

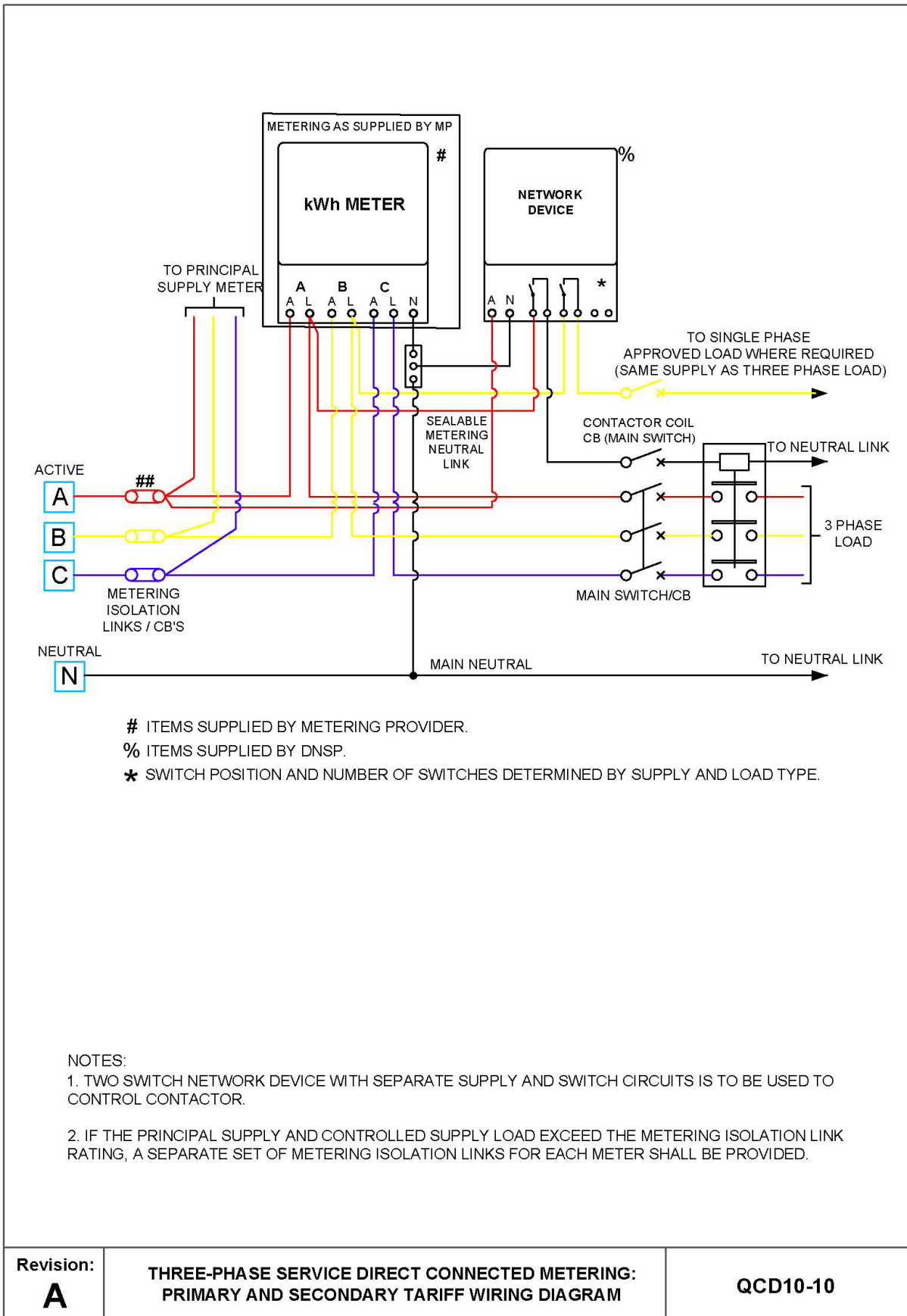

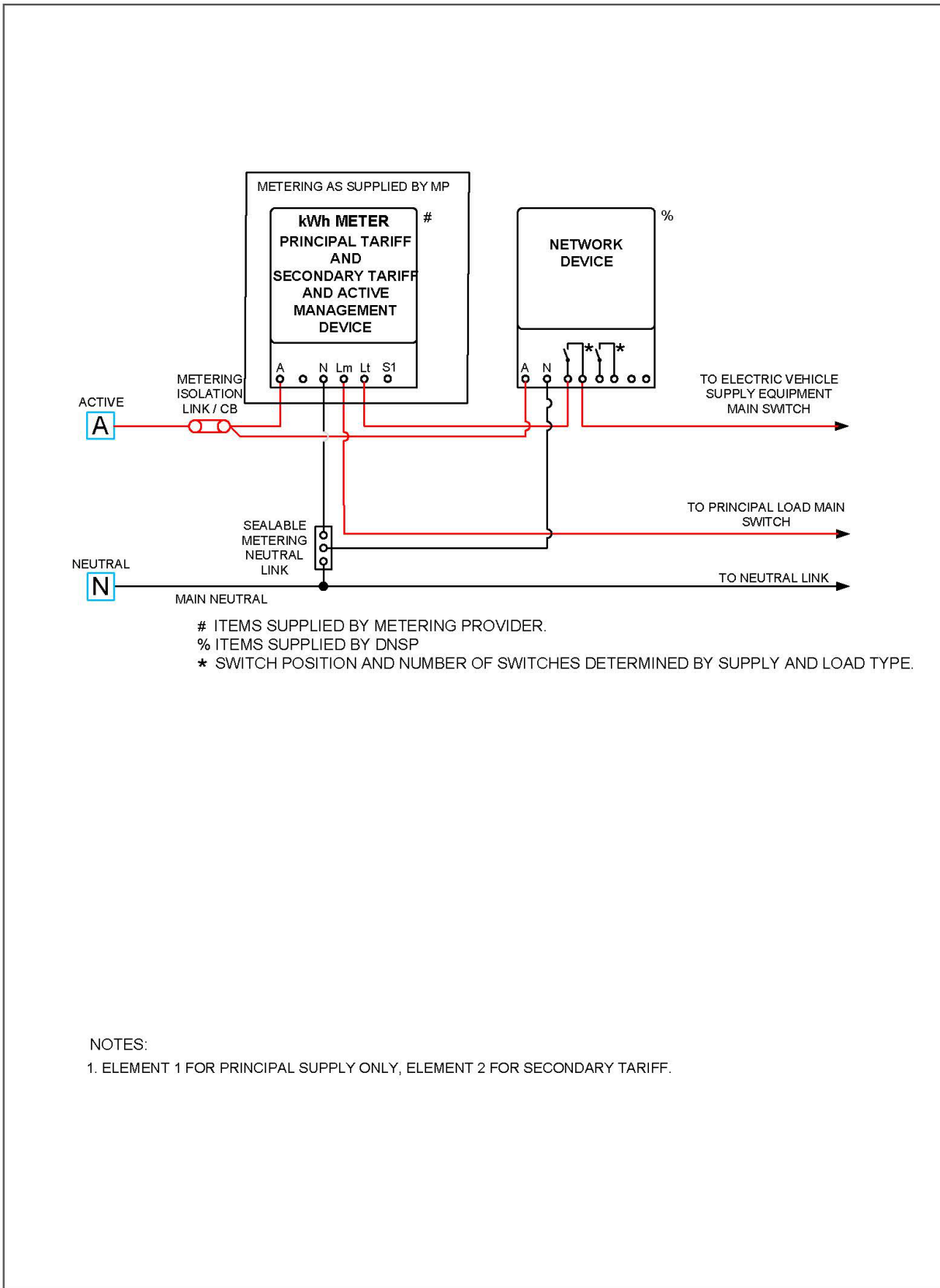

<b>Revision:</b> <b>A</b>	<b>SINGLE-PHASE SERVICE DIRECT CONNECTED METERING: PRIMARY AND CONTROLLED TARIFF WITH ELECTRIC VEHICLE WIRING DIAGRAM</b>	<b>QCD10-11</b>
------------------------------	---	-----------------

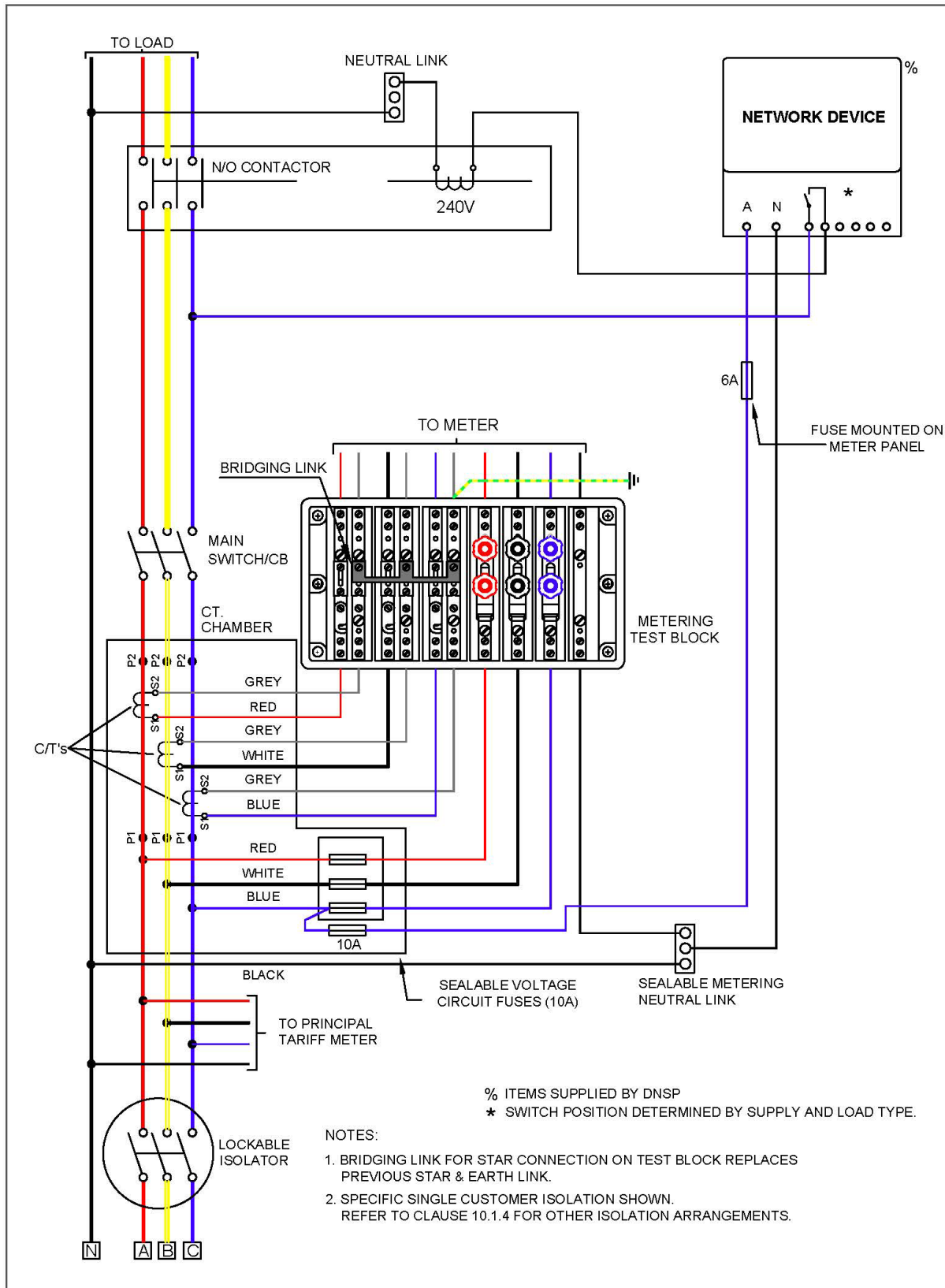

<p>Revision: <b>A</b></p>	<p><b>THREE-PHASE SERVICE CT METERING: PRIMARY AND SECONDARY TARIFF WIRING DIAGRAM</b></p>	<p><b>QCD10-12</b></p>
-------------------------------	--	------------------------

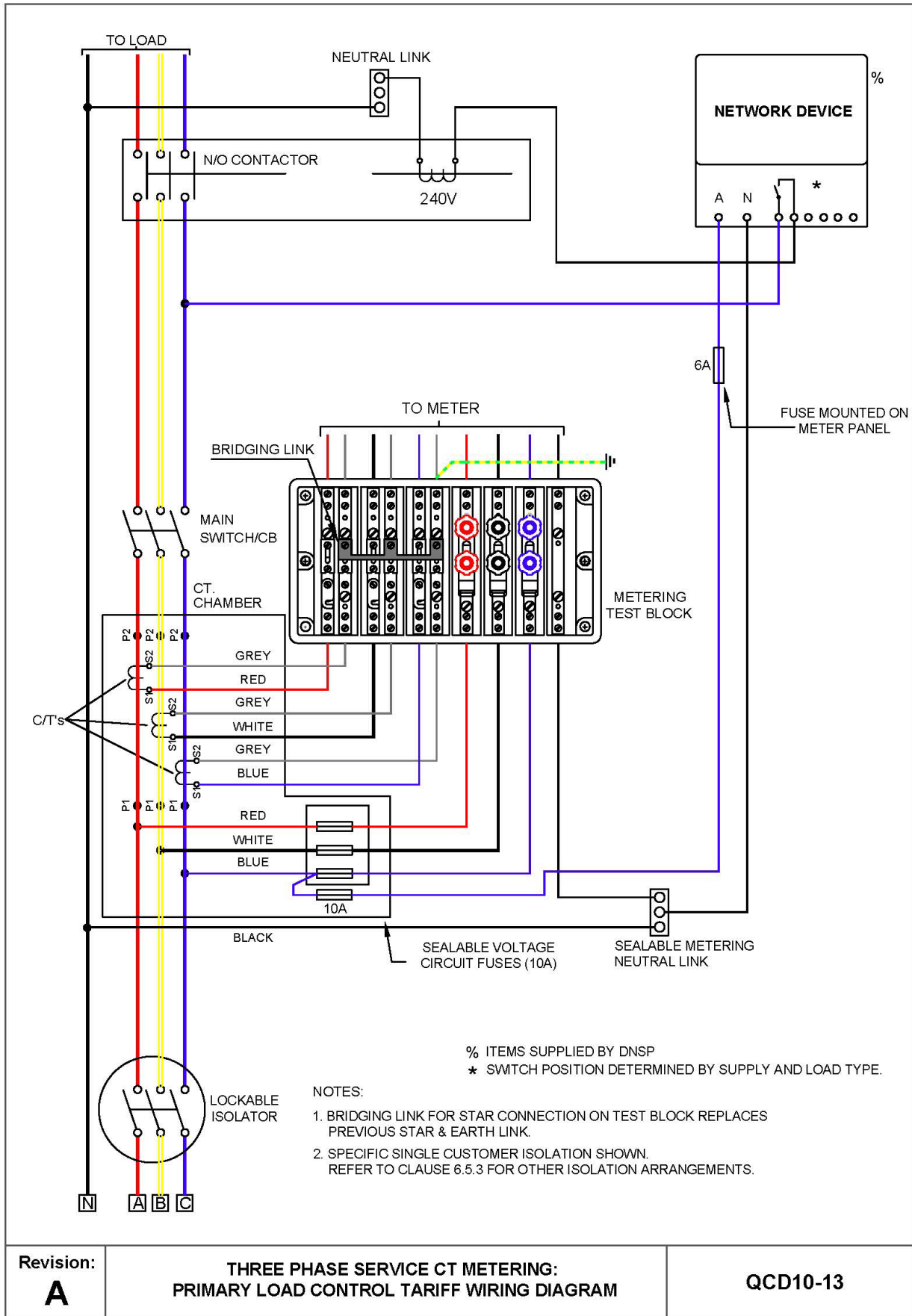

## Appendix B: Activities requiring approval (normative)

Where an activity is being planned that requires approval, information shall be provided by the *Proponent* to the *DNISP* based on the type of activity and may include some of the following below (but not limited to):

**Table 58 Minimum information required for activities requiring approval**

Clause	Activity	Information to be provided
4.5.2.2	Mid-span service	<ul style="list-style-type: none"> <li>Site details.</li> </ul>
5.2.5	Provision of additional <i>DNISP</i> service point	<ul style="list-style-type: none"> <li>Detailed site sketch including existing and proposed service point location and distances.</li> <li>Detailed justification.</li> </ul>
6.7.3(h)	Height of POA	<ul style="list-style-type: none"> <li>Detailed site sketch including the proposed height.</li> <li>Detailed justification.</li> <li><i>Premises</i> details.</li> </ul>
6.7.5	Raiser Bracket	<ul style="list-style-type: none"> <li>Form 12 &amp; 16 of Raiser bracket.</li> <li>Mounting structure details e.g. details of the existing slab and carport as being structurally sufficient to support the applied loads from the bracket.</li> <li>Raiser Bracket <i>RPEQ</i> certification.</li> </ul>
6.7.6	Property Pole	<ul style="list-style-type: none"> <li><i>RPEQ</i> certification Form 12.</li> <li>Manufacturing drawings drawn with a computer-aid drawing package.</li> <li>Detailed design information.</li> <li>Foundation requirements.</li> </ul>
6.8.1	<i>Consumer mains</i> on the <i>DNISP</i> pole	<ul style="list-style-type: none"> <li>Detailed site sketch -including distances to <i>DNISP</i> assets.</li> <li>maximum demand.</li> <li>justification.</li> </ul>
9.8.5.1	Unmetered submains	<ul style="list-style-type: none"> <li>proposed <i>meter board</i> positions.</li> <li>voltage drop calculation.</li> <li>detailed justification.</li> </ul>

# Queensland Electricity Connection Manual



Part of Energy Queensland

Clause	Activity	Information to be provided
9.10.6	Platform requirements	<ul style="list-style-type: none"><li>• RPEQ certification Form 12.</li><li>• Manufacturing drawings drawn with a computer-aid drawing package.</li><li>• Detailed design information.</li><li>• Foundation requirements.</li></ul>
9.11.2	LV CT metering drawings	<ul style="list-style-type: none"><li>• Contractor details.</li><li>• Connection details &amp; address.</li><li>• Meter panel location.</li><li>• Switchboard layout drawings.</li><li>• Single line diagram drawings.</li></ul>
10.4.1	Card Operated Metering	<ul style="list-style-type: none"><li>• Detailed justification from Queensland Department of Housing.</li><li>• Proposed meter board positions.</li><li>• Single line diagram showing locations and MEN shall be located in meter board</li></ul>

## Appendix C: Model standing offer (informative)

The Model Standing Offers for Energex are available at:

Basic Connection Service Model Standing Offer	Website Location
Metered loads (e.g., homes, businesses, metered pumps, etc)	<a href="https://www.energex.com.au/_data/assets/pdf_file/0008/340748/MSO-Basic-Connecting-Metered-Load-EGX-3070111.pdf">https://www.energex.com.au/_data/assets/pdf_file/0008/340748/MSO-Basic-Connecting-Metered-Load-EGX-3070111.pdf</a>
Solar PV systems and other <i>generating units</i> under 30kVA	<a href="https://www.energex.com.au/_data/assets/pdf_file/0006/340593/Model-Standing-Offer-Basic-Connection-MEG-Form-3072.pdf">https://www.energex.com.au/_data/assets/pdf_file/0006/340593/Model-Standing-Offer-Basic-Connection-MEG-Form-3072.pdf</a>
Solar PV systems and other <i>generating units</i> 30kVA to 200kVA	<a href="https://www.energex.com.au/_data/assets/pdf_file/0004/835492/Model-Standing-Offer-Basic-Connection-IES-Form-0646.pdf">https://www.energex.com.au/_data/assets/pdf_file/0004/835492/Model-Standing-Offer-Basic-Connection-IES-Form-0646.pdf</a>
Approved unmetered devices (e.g., security cameras, traffic lights, illuminated signs, rail crossing signals, etc)	<a href="https://www.energex.com.au/_data/assets/pdf_file/0008/340757/Model-Standing-Offer-Standard-Connection-Unmetered-Form-3062.pdf">https://www.energex.com.au/_data/assets/pdf_file/0008/340757/Model-Standing-Offer-Standard-Connection-Unmetered-Form-3062.pdf</a>

The Model Standing Offers for Ergon Energy Network are available at:

Basic Connection Service Model Standing Offer	Website Location
Metered loads (e.g., homes, businesses, metered pumps, etc)	<a href="https://www.ergon.com.au/_data/assets/pdf_file/0011/269894/MSO-Basic-Connecting-Metered-Load-EE-11042359.pdf">https://www.ergon.com.au/_data/assets/pdf_file/0011/269894/MSO-Basic-Connecting-Metered-Load-EE-11042359.pdf</a>
Solar PV systems and other <i>generating units</i> under 30kVA	<a href="https://www.ergon.com.au/_data/assets/pdf_file/0012/269895/SR000100R103-Model-Standing-Offer-for-micro-EG.pdf">https://www.ergon.com.au/_data/assets/pdf_file/0012/269895/SR000100R103-Model-Standing-Offer-for-micro-EG.pdf</a>
Solar PV systems and other <i>generating units</i> 30kVA to 200kVA	<a href="https://www.ergon.com.au/_data/assets/pdf_file/0003/835554/SR000101R115-Model-Standing-Offer-connecting-MEGUs.pdf">https://www.ergon.com.au/_data/assets/pdf_file/0003/835554/SR000101R115-Model-Standing-Offer-connecting-MEGUs.pdf</a>
Approved unmetered devices (e.g., security cameras, traffic lights, illuminated signs, rail crossing signals, etc)	<a href="https://www.ergon.com.au/_data/assets/pdf_file/0010/269893/Model-Standing-Offer-Basic-Approved-Unmetered-Device.pdf">https://www.ergon.com.au/_data/assets/pdf_file/0010/269893/Model-Standing-Offer-Basic-Approved-Unmetered-Device.pdf</a>

# Queensland Electricity Connection Manual

## Appendix D: Static data and information (informative)

Static data and information shall be provided by the *Proponent* to the *DNISP* based on your application type and may include some of the following below (but not limited to):

1. *NMI* meter numbers.
2. System information:
  - a. Detailed single line diagram demonstrating motors, large loads, *EG Units* connected, and proposed for connection, at the *premises* (including detail of any interlocking).
  - b. Number of phases available.
  - c. Energy source.
  - d. Maximum demand, capacity, and output rating.
  - e. Any proposed *export* limit for DER (Full / Partial- / Non- / minimal) and method of *export* control.
  - f. Metering scheme information (gross or net).
3. Device information:
  - a. Type (e.g., motor, pump, mill, chiller, inverter, panel, battery).
  - b. Make, model and manufacturer.
  - c. Number installed.
4. Applicant and *Customer* information:
  - a. Type.
  - b. Business and / or Personal Names.
  - c. Address and contact information.
5. *Electrical Contractor*, *RPEQ*, Consultant and/or Installer information.
6. *Dynamic* DER Registration information.

# Queensland Electricity Connection Manual

## Appendix E: *Dynamic* data and information (informative)

*Dynamic* data and information shall be provided by the *Proponent* to the *DNSP* or by the *DNSP* to the *Proponent* based on the application type and may include (but is not limited to) the following:

**Table 59** *Dynamic* monitoring information via CSIP-AUS

Measurement	Data Qualifier	Site	DER <sup>1</sup>
Real Power (W/phase)	Average	Mandatory	Mandatory
Reactive Power (Var/phase)	Average	Mandatory	Mandatory
Voltage (V/phase)	Average	Mandatory	Optional

Note 1 – Measurements from Metering Mirror function set.

Note 2 – DER telemetry is total of aggregated *actively managed devices*.

Note 3 – At least one site or device voltage must be reported. Where site voltage is available, it must be reported.

**Table 60** *Dynamic* control functions via CSIP-AUS

Category	Support Function	DER control requirements
<i>Export</i> limit	DERControlBase within the DERControl.	DERControlBase:csipaus:opModExpLimW(Watts) and DERControlBase:opModMaxLimW(PerCent)
<i>Import</i> limit	DERControlBase within the DERControl.	DERControlBase:csipaus:opModImpLimW
Actively Managed Load limit	DERControlBase within the DERControl.	DERControlBase:csipaus:opModLoadLimW
Generation limit	DERControlBase within the DERControl.	DERControlBase:csipaus:opModGenLimW and DERControl:opModEnergize
Forecasting <sup>1</sup>	Forecasting using DERControl.	Using DERControl events
Loss of communications revert to fixed limits	DefaultDERControl.	<i>DefaultDERControl</i> ; and <i>setGradW</i>

Note 1 – Capable of supporting a minimum of five-minute interval envelope events for the next hour and thirty-minute interval events for the following 23 hours, updated every five minutes under normal circumstances. (58 events per *connection point*).

# Queensland Electricity Connection Manual

## Appendix F: Compliance checklists (informative)

Table 61 LV connection direct current metering check sheet for *Electrical Contractors*

Electrical Contractor's LV Connection Direct Current Metering Check Sheet			
Address where direct current metering installed:			
National Metering Identifier (NMI) (If known):			
Details of electrical mechanic responsible for testing of direct current <i>metering installation</i> :			
Name:		Licence No:	
Clause No.	Checklist	Checked	Comments
<b>General Requirements</b>			
	Connection agreement – new installation or load change		
	Number of phases to be installed		
<b>Overhead Connection</b>			
	POA maximum 20 m from property boundary		
	<i>OH Service line</i> does not cross neighbouring property boundary in aerial trespass		
	POA or <i>OH service line</i> is not over or within pool zone		
	POA requirements met		
	Property pole connection <i>RPEQ</i>		
<b>Underground Connection</b>			
	Confirm availability of supply		
	Pillar connection		
	<i>LV</i> striple in padmount connection		
<b>Meter Connection Requirements</b>			
	No <i>Customer</i> equipment installed before the metering		
	Metering determination		
	Addition & Alteration category of works		
	Metering Isolation Link ( <i>MIL</i> )		
	Metering Neutral Link		
	Conductor identification		
	Main Switch and <i>MEN</i> at meter position		
	Meter panel location		
	Spacing requirements		
	Meter panel mounting		
	Metering height		
<b>Additional Requirements</b>			
AS/NZS 3000	Test continuity to confirm that cabinets are earthed		
<i>MIR</i>	All requirements of the <i>MIR</i> met		

# Queensland Electricity Connection Manual

Table 62 LV connection *current transformer* metering check sheet for *Electrical Contractors*

<b>Electrical Contractor's LV Connection CT Metering Check Sheet</b>			
<b>Address where CT metering installed:</b>			
<i>National Metering Identifier (NMI)</i> (If known):			
<b>Details of electrical mechanic responsible for testing of CT installation:</b>			
<b>Name:</b>		<b>Licence No:</b>	
<b>Clause No.</b>	<b>Checklist</b>	<b>Checked</b>	<b>Comments</b>
Table 13	RPEQ compliance for Switchboards where switchgear assemblies compliant with AS/NZS 61439		
<b>Switchboard/CT Chamber</b>			
10.1.4.1(b)	Lockable isolator on line side of CTs		
<i>MIR</i>	Dedicated CT chamber provided		
<i>MIR</i>	CT chamber correctly labelled		
<i>MIR</i>	Removable CT chamber cover fitted with 2 handles		
<b>Current Transformers</b>			
<i>MIR</i>	CT ratio matches expected load		
9.10.4 (b)	No exposed live parts within CT chamber		
<i>MIR</i>	Primary and secondary polarity is correct		
<i>MIR</i>	Removable bus bars allow CTs to be easily replaced		
<i>MIR</i>	CT secondary terminals are accessible		
<b>Voltage Circuit Fuses</b>			
<i>MIR</i>	Fuses carriers are accessible and easily removable		
<i>MIR</i>	Fuses are connected to the line side of the CTs		
<i>MIR</i>	Cables from bus bars to fuses are $\leq 500\text{mm}$ and a minimum of $10\text{mm}^2$ SDI		
<i>MIR</i>	Correct marking of cables from bus bars to fuses (e.g. trace or bell out cables)		
<b>Meter Neutral &amp; Earthing</b>			
AS/NZS 3000	Test continuity to confirm that cabinets are earthed		
<i>MIR</i>	Meter neutral is connected to main neutral and meter neutral label is attached		
<b>Meter Panel Wiring &amp; Test Block</b>			
9.8	Meter panel located in suitable location		
<i>MIR</i>	Meter panel size is minimum $600 \times 600\text{mm}$ (or $460 \times 600\text{mm}$ for single tariff CT installation)		
<i>MIR</i>	Meters are mounted at correct height		
<i>MIR</i>	Meter panel is hinged		
<i>MIR</i>	Meters and wiring spaced from heavy current carrying conductors		
<i>MIR</i>	Test block is mounted correctly		
<i>MIR</i>	Colour coding is correct		
<i>MIR</i>	Meter wiring is correct size for circuit length		
<i>MIR</i>	Secondary returns are starred and earthed		
<b>Sealing</b>			
<i>MIR</i>	CT chamber, voltage circuit fuses and meter panel are sealable		

# Queensland Electricity Connection Manual

## Appendix G: Isolated Networks (normative)

### G.1 Isolated Networks Map

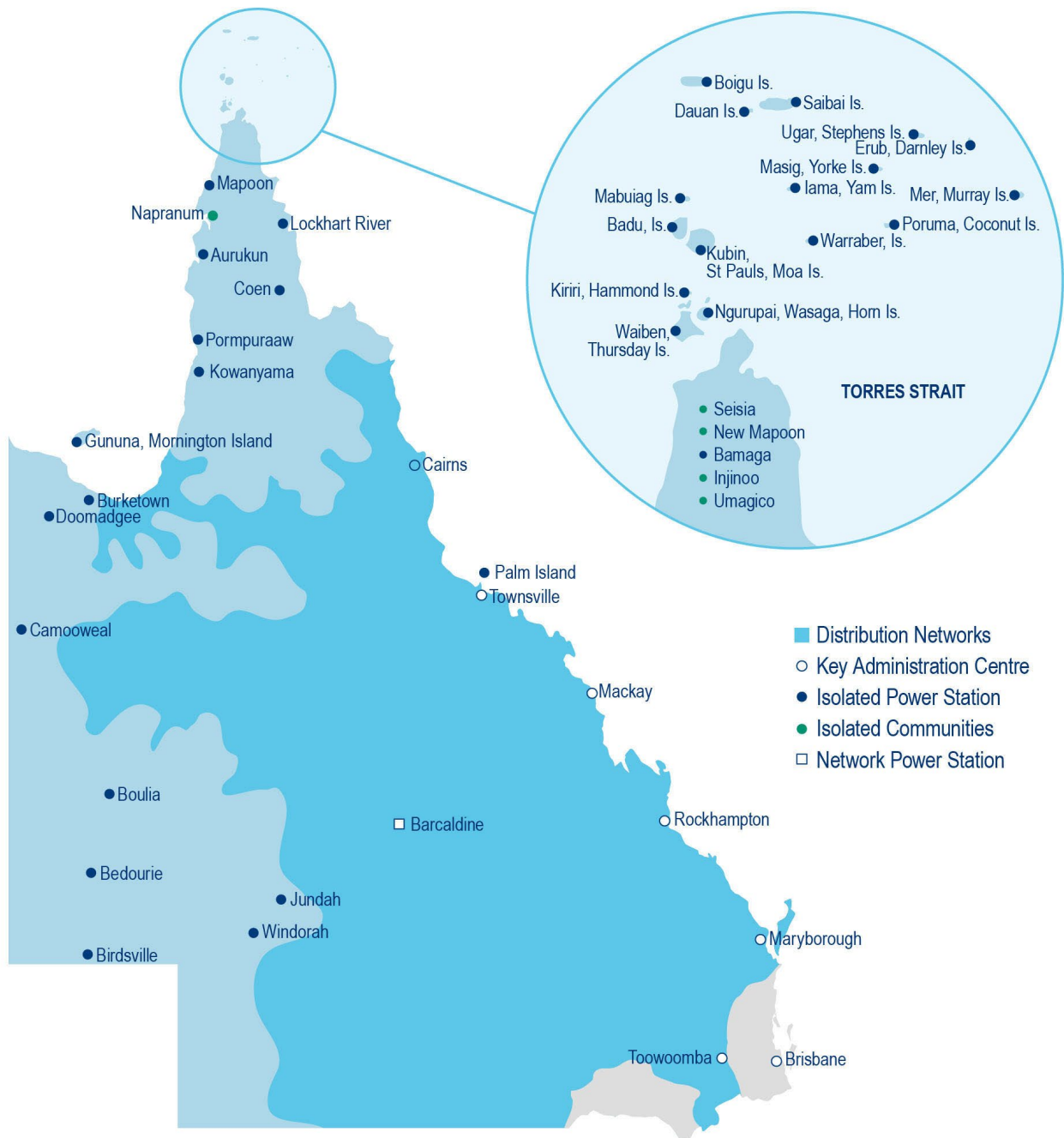

Figure 8 2: Ergon Energy Network *isolated network* supply area map

# Queensland Electricity Connection Manual

## G.2 Maximum permitted rating of AC motors in isolated networks

**Table 63** Maximum permitted rating of AC motors in *isolated networks*

Locality <sup>1</sup>	Maximum rating (kW)
Stephens Island, Ugar	4 kW
Hammond Island, Kiriri	5 kW
Dauan Island	7 kW
Mabuiag Island	
Warraber Island	
Darnley Island, Erub	8 kW
Saibai Island	
Boigu Island	10 kW
Coconut Island, Poruma	
Moa Island (Kubin and St Pauls communities)	
Yam Island, lama	
Yorke Island, Masig	
Bedourie	12 kW
Birdsville	
Jundah	
Mapoon	
Windorah	
Badu Island	13 kW
Coen	
Murray Island, Mer	
Aurukun	16 kW
Boulia	
Burketown	
Camooweal	
Lockhart River	
Pormpuraaw	
Doomadgee	37 kW
Gununa, Mornington Island	
Kowanyama	
Wasaga, Ngurupai, Horn Island	
Palm Island	38 kW
Bamaga (Seisia, New Mapoon, Bamaga, Injinoo and Umagico communities)	46 kW

# Queensland Electricity Connection Manual

## Appendix H: Specification for metallic enclosures for direct connected metering installations (normative)

### H.1 Introduction

#### H.1.1 Scope

This specification provides standard requirements for metallic *enclosures* for *network devices* and *metering equipment* connected to *DNISP* supply and used in *direct connected* installations.

#### H.1.2 Definitions

**Table 64** Definitions for specification for metallic enclosures for Direct Connected *metering installations*

Term	Definition
direct connected installation	means an installation that is metered by Direct Connected meters.
enclosure	means an enclosure used for the purpose of housing <i>network devices</i> and metering equipment.
meter panel	means a panel to be mounted in the <i>enclosure</i> and on which metering equipment is fixed.
metering equipment	means the equipment used for measuring or controlling the supply of electrical energy.
weatherproof	means so constructed and installed as to exclude rain, hail, and external splashing so that the safe and efficient operation of the equipment contained therein shall not be impaired. (e.g., IP23).

### H.2 Dimensions

- (a) Two basic types of *enclosures* are provided for in Table 63, the dimensions of which are to be suitable for recessing into brick, block, or framed walls.
- (b) *Enclosures* may meet the dimensions for a Type A or Type B shown in Table 63. *Enclosures* may be of other dimensions with adequate size to house the *network devices* and *metering equipment* with recommended clearances, meeting the design and construction requirements of this specification.
- (c) *Meter panels* shall meet the minimum dimensions requirements in Table 63.

# Queensland Electricity Connection Manual

Table 65 Type A and Type B enclosure and meter panel dimensions

Meter enclosure	Minimum Thickness Mild Steel	Minimum Space Required For Metering Equipment	Clearance From Back of Meter Panel to Back of Enclosure	Clearance From Back of Meter Panel to Inside of Door
Type A	1.0 mm	480mm x 460mm (H) x (W)	75 mm	185 mm
Type B	1.2 mm	600mm x 550mm (H) x (W)		

Note 1: This Table is indicative of the most commonly supplied metering enclosures that comply with this *manual*.

## H.3 Design and construction

### H.3.1 Materials

The *enclosure* may be constructed from the materials in Table 64.

Table 66 *Network device and metering enclosure materials for construction*

Material	Minimum thickness (mm)
Mild steel	Meter enclosure Type A 1.0
	Meter enclosure Type B 1.2
Aluminium	To be equivalent in strength and rigidity to the above mild steel requirements

### H.3.2 Construction

- (a) The *enclosure* should be constructed free of burrs at the opening.
- (b) *Enclosures* constructed of steel shall be:
  - (i) of galvanised or zincalume material; and
  - (ii) comply with AS 1397.
- (c) Galvanised steel *enclosures* shall:
  - (i) have all galvanised surfaces repaired with a suitable zinc rich coating; and
  - (ii) all exterior surfaces of the *enclosure* should be painted with one coat of "etch primer".
- (d) *Enclosures* constructed of aluminium shall be restricted to corrosion resistant alloys as recommended for the exposure to be encountered in service (stainless steel is an acceptable alternative).
- (e) Rivets shall be of a material that is compatible with the case material and must not react to set up points of corrosion.
- (f) Where additional mechanical strength is required, stiffening ribs may be utilised. Such ribs must not in any way reduce the minimum internal dimensions.

# Queensland Electricity Connection Manual

## H.3.3 Door

- (a) The *enclosure* shall be fitted with a hinged door of sufficient strength to prevent buckling or warping.
- (b) The *enclosure* door shall be side hinged, unless otherwise approved by the *Metering Provider*, and:
  - (i) fitted with a suitable non-corroding chain or other approved means to limit the door travel to approximately 100 degrees; and
  - (ii) it may be hinged at either the left or right side of the *enclosure*;
  - (iii) the door hinge shall be fitted with a simple self-latching device compliant with AS 1397;
  - (iv) the door hinge shall be constructed of non-corroding material and so designed or fitted with non-corroding pins as to prevent seizing.

## H.3.4 Door latch

The door latching device provided shall engage automatically and hold the door firmly closed.

## H.3.5 Entry of wiring

Adequate provisions shall be made for knockouts or slots for the entry of wiring to the meter enclosure (refer to AS/NZS 3000 for fire protection requirements).

## H.3.6 Earthing

- (a) To ensure an effective earth of the switchboard surround an earthing stud or terminal complying with the requirements of AS/NZS 3000 shall be provided for the connection of an earthing conductor within the *enclosure*.
- (b) The stud or terminal shall not obstruct equipment within the *enclosure*.

## H.3.7 Weatherproofing

- (a) The *enclosure* shall be *weatherproof* and comply with AS/NZS 60529 to a minimum of IP23.
- (b) The *enclosure* shall provide adequate ventilation to minimise condensation; and
- (c) be capable of draining any moisture that may collect within the *enclosure*.

## H.3.8 Meter panel

The following requirements apply to *meter panels*:

- (a) Shall be constructed of durable, non-conducting, fire resistant material with low water absorption properties.
- (b) Shall not contain asbestos.
- (c) Shall be side hinged on a vertical axis so that the *metering equipment* always remains in the vertical plane.
- (d) Panel hinges:
  - (i) Should be of the double off-set type that allows for the panel to be swung into the fully opened position.
  - (ii) Shall be of adequate strength to support the *meter panel* and associated *network devices and metering equipment*.
  - (iii) Shall be constructed of a suitable non-corroding material.
- (e) When the *meter panel* is opened at an angle of 90 degrees, the design of the enclosure and hinges should be such to withstand without undue distortion a weight of 25kg suspended vertically at a position 25mm from the outer edge of the panel.

# Queensland Electricity Connection Manual

## Appendix I: Controlled tariff requirements (normative)

### I.1 Primary controlled tariff

#### I.1.1 Eligible participants

The following *Customers* are eligible to connect a primary controlled tariff with the conditions shown in the relevant *DNSP's* Network Tariff Guide. Business *Customers* that are either:

- (a) SAC small; or
- (b) SAC large.

#### I.1.2 Eligible equipment

Table 67 Eligible equipment for connection to a primary load control tariff

Category	Eligible equipment for connection to a load control tariff
General circuits	(a) Lighting
	(b) General power
Water heater	(c) Electric storage <sup>1</sup>
	(d) Boost elements of solar-heated
	(e) Heat pump
Other appliances	(f) Pool filtration systems
	(g) Washing machines, dishwashers etc.
	(h) Air-conditioners
Farming	(i) Pumping and irrigation equipment
Electric vehicles	(j) <i>EVSE</i>
<i>Embedded generating systems</i>	(k) BESS
	(l) Solar <i>PV</i>

Note 1: Electric storage water heater equipment with thermostatically controlled or continuously operating heating units.

#### I.1.3 Connection of eligible equipment

Eligible equipment shown in Table 65 shall be connected to the primary control tariff circuit as follows:

- (a) Permanent connection to the *electrical installation*; or
- (b) supplied through a socket.

### I.2 Secondary controlled tariff

#### I.2.1 Eligible participants

The following *Customers* are eligible to connect a secondary controlled tariff with the conditions shown in the relevant *DNSP's* Network Tariff Guide:

- (a) Residential *Customers* that are either:
  - (i) SAC small; or
- (b) business *Customers* that are either:
  - (i) SAC small; or
  - (ii) SAC large.

#### I.2.2 Eligible equipment

# Queensland Electricity Connection Manual

**Table 68 Eligible equipment for connection to a secondary load control tariff**

Category	Eligible equipment for connection to a load control tariff
Water heater	(a) Electric storage <sup>1</sup>
	(b) Boost elements of solar-heated
	(c) Heat pump
Other appliances	(d) Pool filtration systems
	(e) Washing machines, dishwashers etc.
	(f) Air-conditioners
Farming	(g) Pumping and irrigation equipment
Electric vehicles	(h) <i>EVSE</i>
<i>Embedded generating systems</i>	(i) <i>BESS</i>
	(j) <i>Solar PV</i>

Note 1: Electric storage water heater equipment with thermostatically controlled or continuously operating heating units.

## I.2.3 Connection of eligible equipment

Eligible equipment shown in Table 66 may be connected to the secondary control tariff circuit as a permanent connection to the *electrical installation*, unless they meet the following criteria:

- (a) Pool filtration systems may be supplied by a dedicated socket on a secondary control tariff; or
- (b) *EVSE* may be supply by a dedicated socket on a secondary control tariff only where the *Customer* is classified as:
  - (i) A domestic *premises*; and
  - (ii) SAC small.

# Queensland Electricity Connection Manual



## Appendix J: Alterations of existing connections (normative)

Table 69 Alterations of existing connections

Category	Alteration works	Major <sup>1,3</sup> alteration	Minor <sup>2</sup> alteration
Multiple	Connect additional phases	Yes	No
<i>Point of attachment</i>	Relocate	Yes	Yes where relocated for safety only and no other alteration works undertaken
<i>Consumer mains</i>	Replace	Yes	No
Meter panel	Works on meter panel where panel not housed in enclosure	Yes	No
	Replace meter panel when meter enclosure not replaced	No	Yes
Meter enclosure	Replace	Yes	No
	Relocate	Yes	No
Metering	Change from direct connect to CT metering	Yes	No
	Change from CT to direct connect metering	Yes	No
	<i>Customer request to change meter</i>	No	Yes
	<i>Add new meter, point of attachment and/or connection point at multiple premises</i>	Yes	No
	Additional tariff requested	No	Yes
	Load centre change	No	Yes
Solar IES	Connect	Yes	Yes where no asbestos in <i>meter board</i> , hinged panel, meter isolation link and metering neutral link.

Note 1 – Where a *Proponent* with *consumer mains* on pole undertakes alteration works classified as a major alteration, the *DNSP* service point shall be relocated to a location compliant with this *manual*.

# Queensland Electricity Connection Manual



Note 2 – Where a single *Proponent* of a multiple *domestic* or *non-domestic premises* connection requires works that fall under minor alterations in clause 4.3.2.2 and is unable to gain support from the body corporate to upgrade metering, they may install a second *meter board* directly next to existing non-compliant meter panel.

Note 3 – For single and multiple *domestic premises* with an existing connection established prior to 2015 undertaking major alteration works under clause 4.3.2.1 and Appendix J:

A *Proponent* may:

- (i) Locate the *meter board* within the first 4 m along an adjacent side of the main building of *premises*, where the *meter board* was connected in this location in the initial connection and it is not located in an unsuitable location under clause 9.7.1.2.
- (ii) Relocate the *meter board* to a location within the first 4 m along an adjacent side of the main building of *premises*, where there is a permanent structural obstruction on side of *premises* (such as windows) preventing installation within 2 m and it is not located in an unsuitable location under clause 9.7.1.2.

## Appendix K: Stakeholder interactive diagrams for connection participants (normative)

See following pages for stakeholder interactive diagrams.

# Queensland Electricity Connection Manual

## K.1: Initial connection of direct connected metering

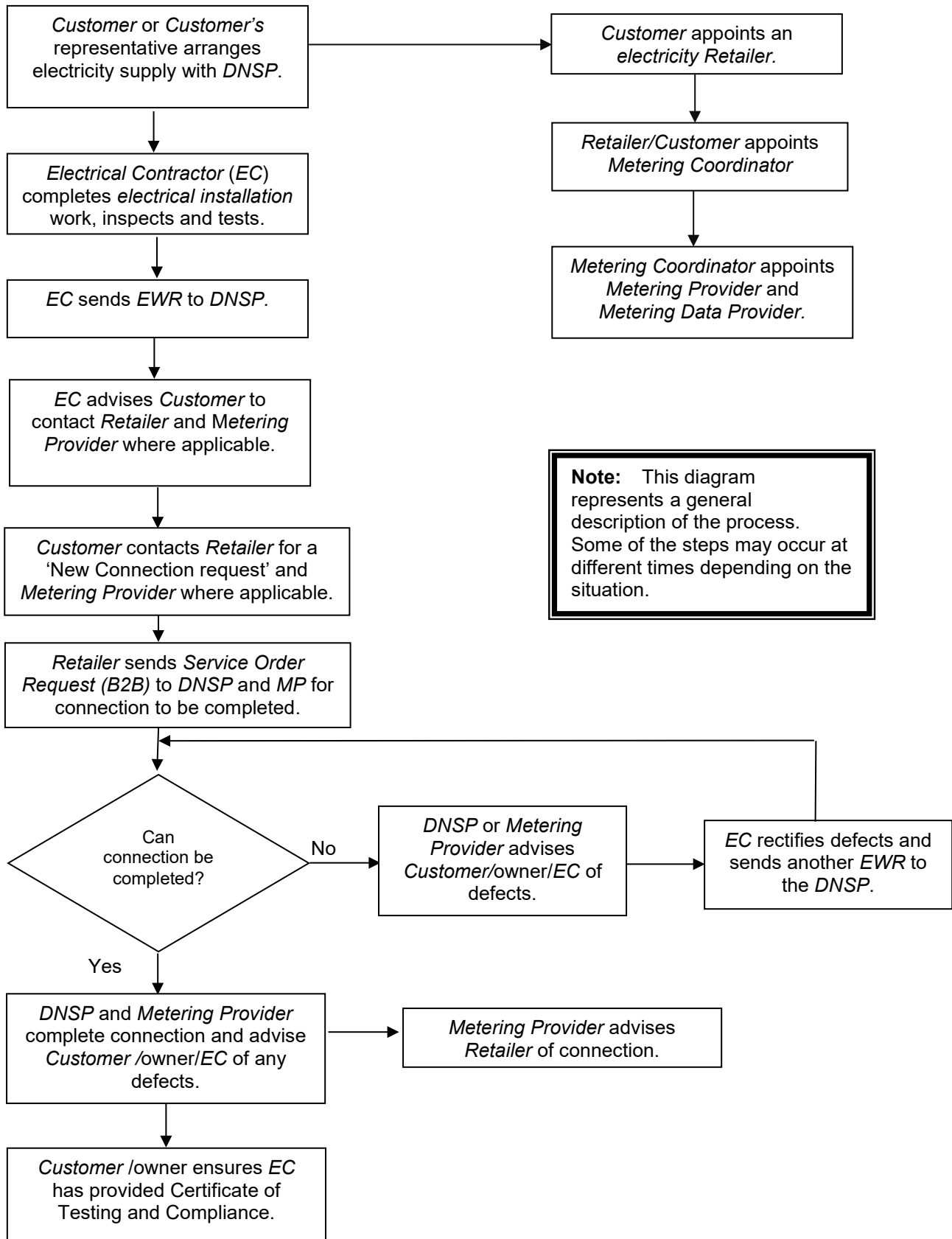

# Queensland Electricity Connection Manual

## K.2: Initial connection of current transformer (CT) metering

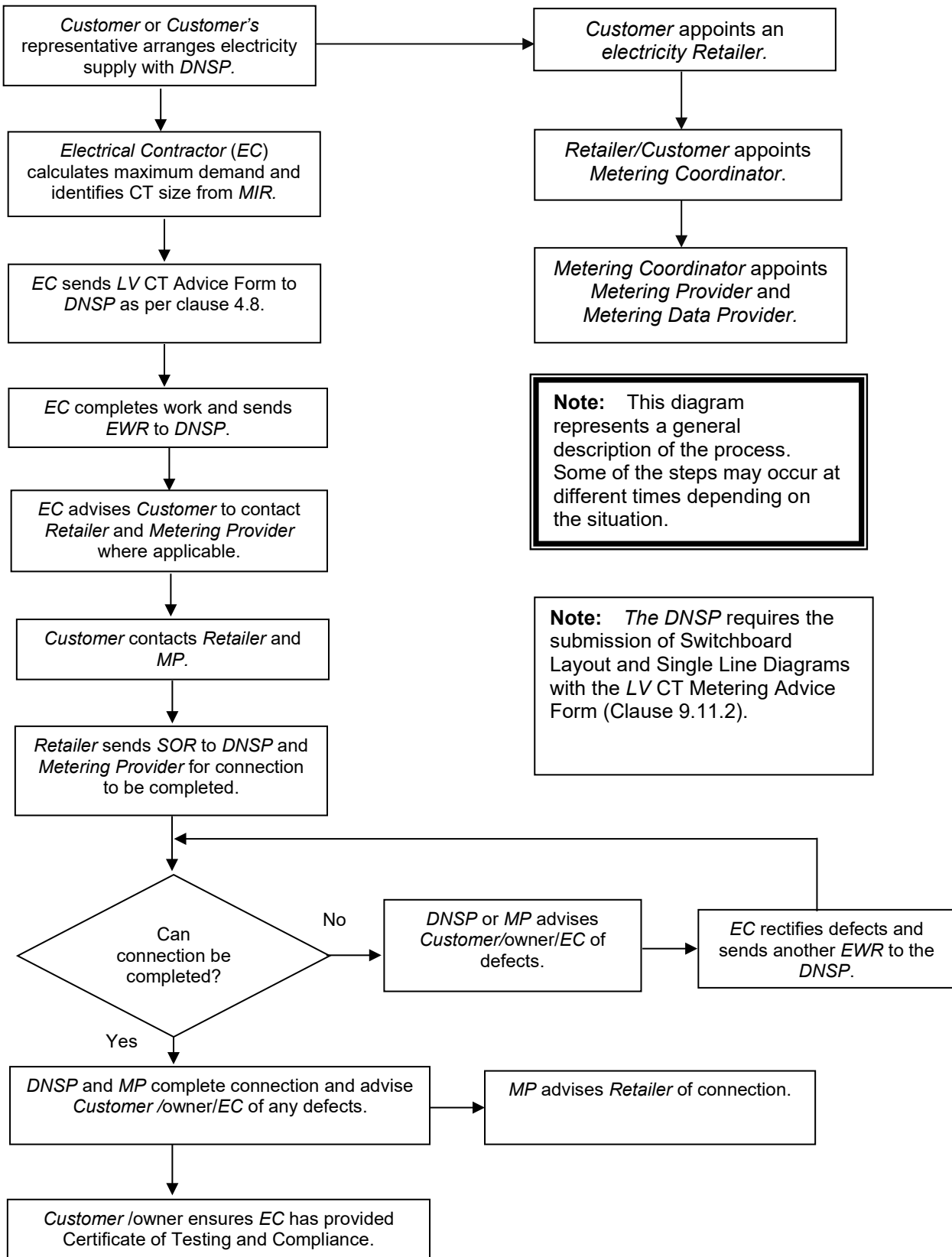

## K.3: *Electrical installation* work involving metering changes

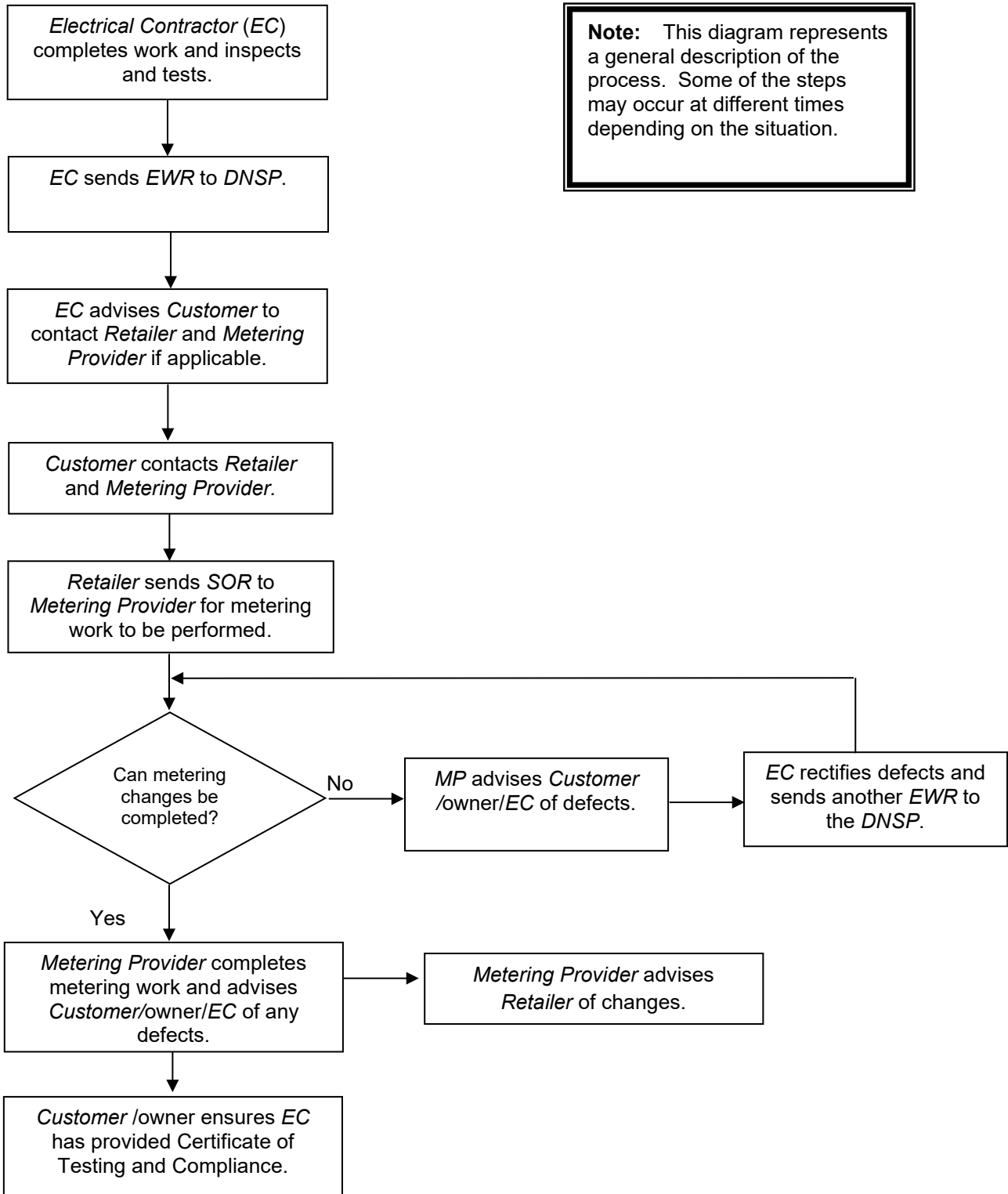

## K.4: Service and metering change for phase upgrade

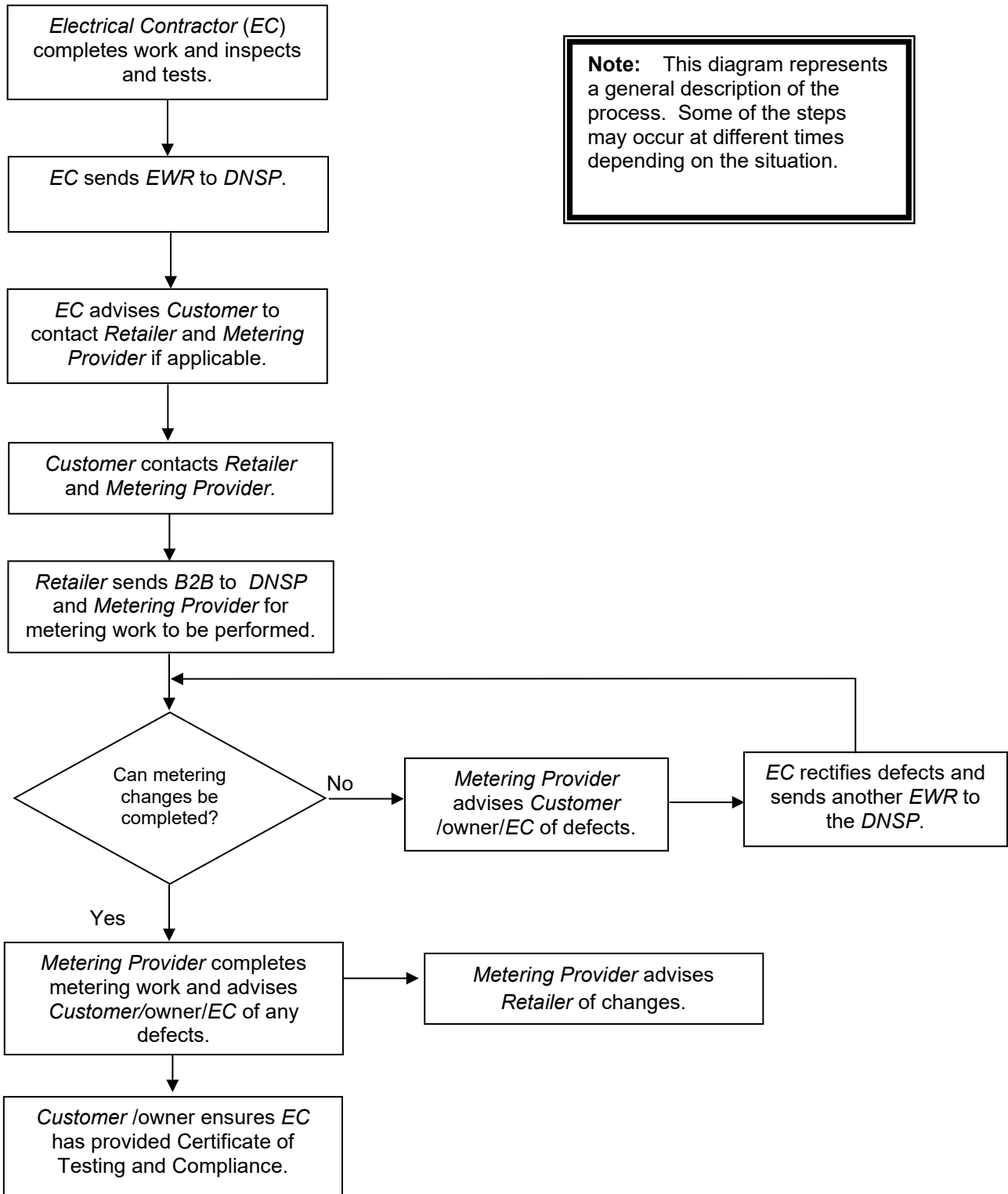

## K.5: Service alteration without metering changes

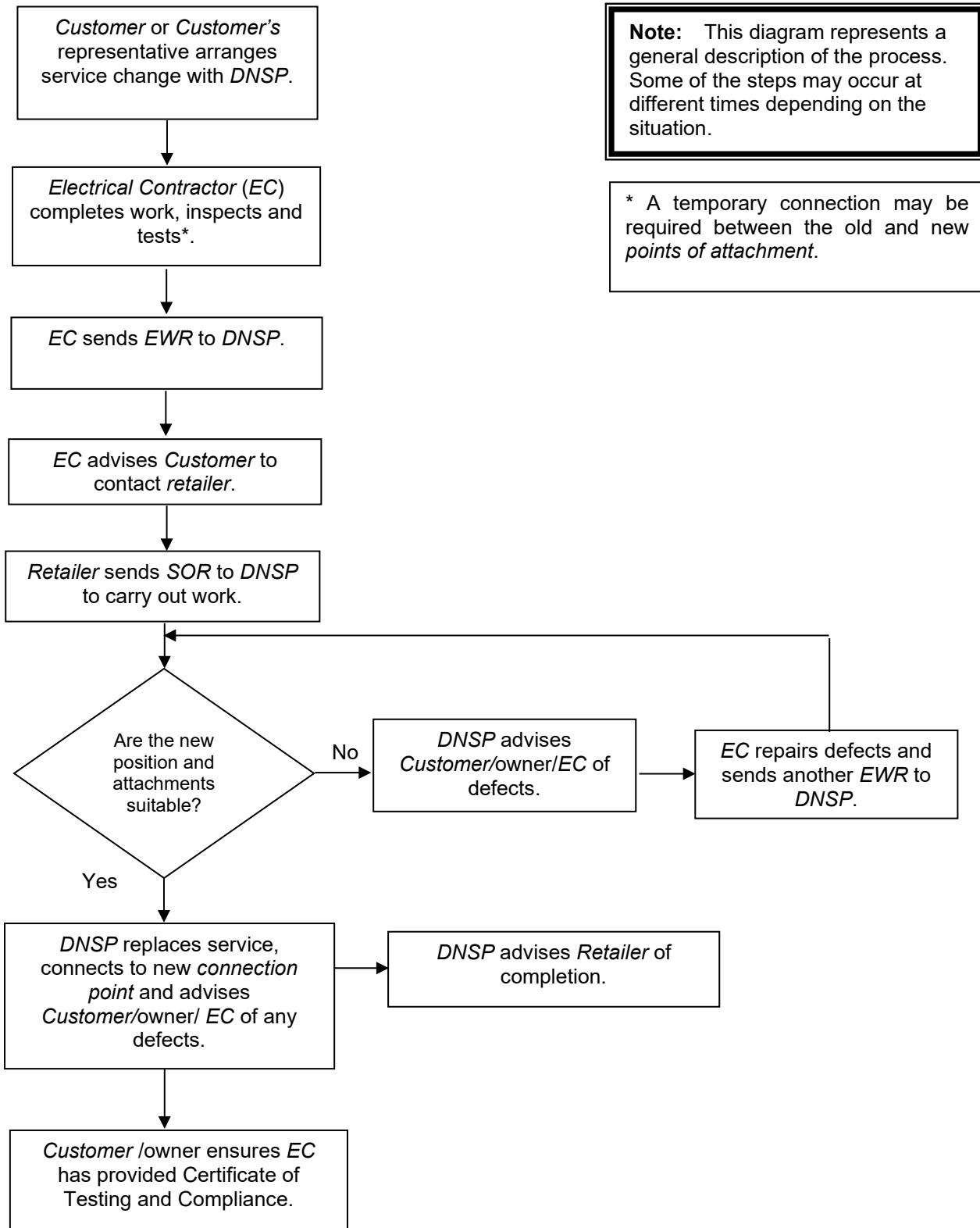

## K.6: Small IES EG connection to an electrical installation

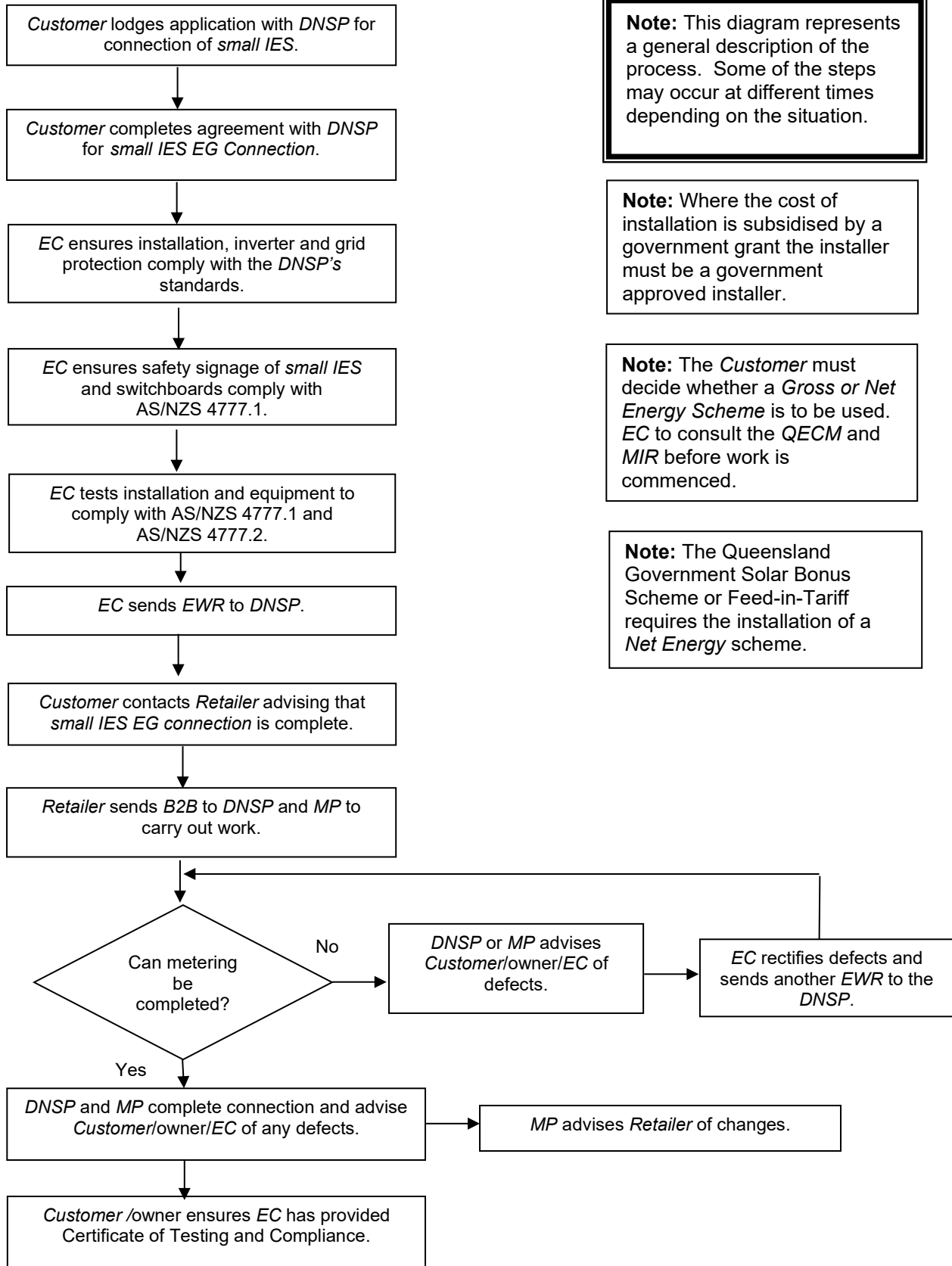

## K.7: Initial connection for a HV connection

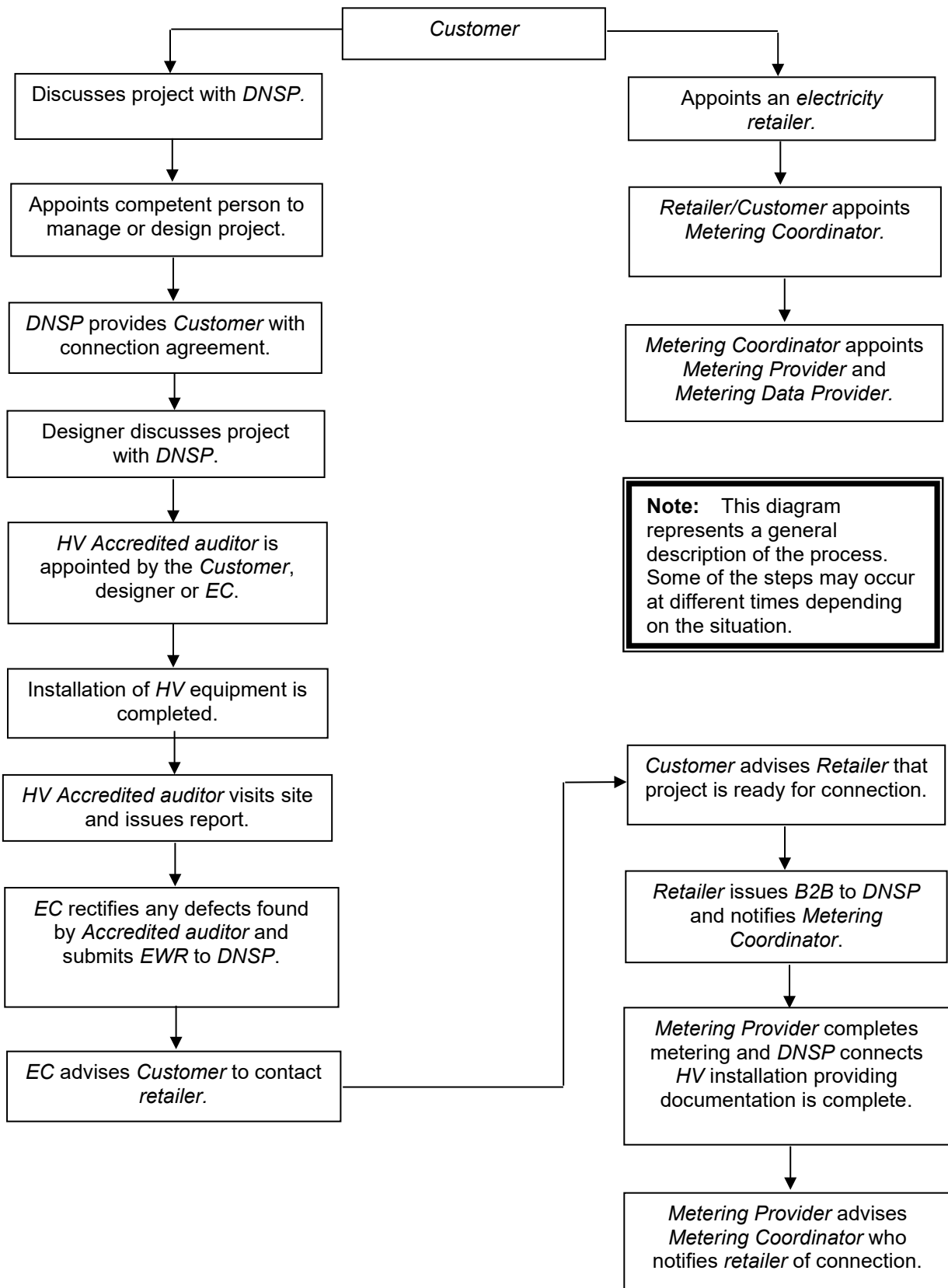

# Queensland Electricity Connection Manual

## Appendix L: DNSP service area map (informative)

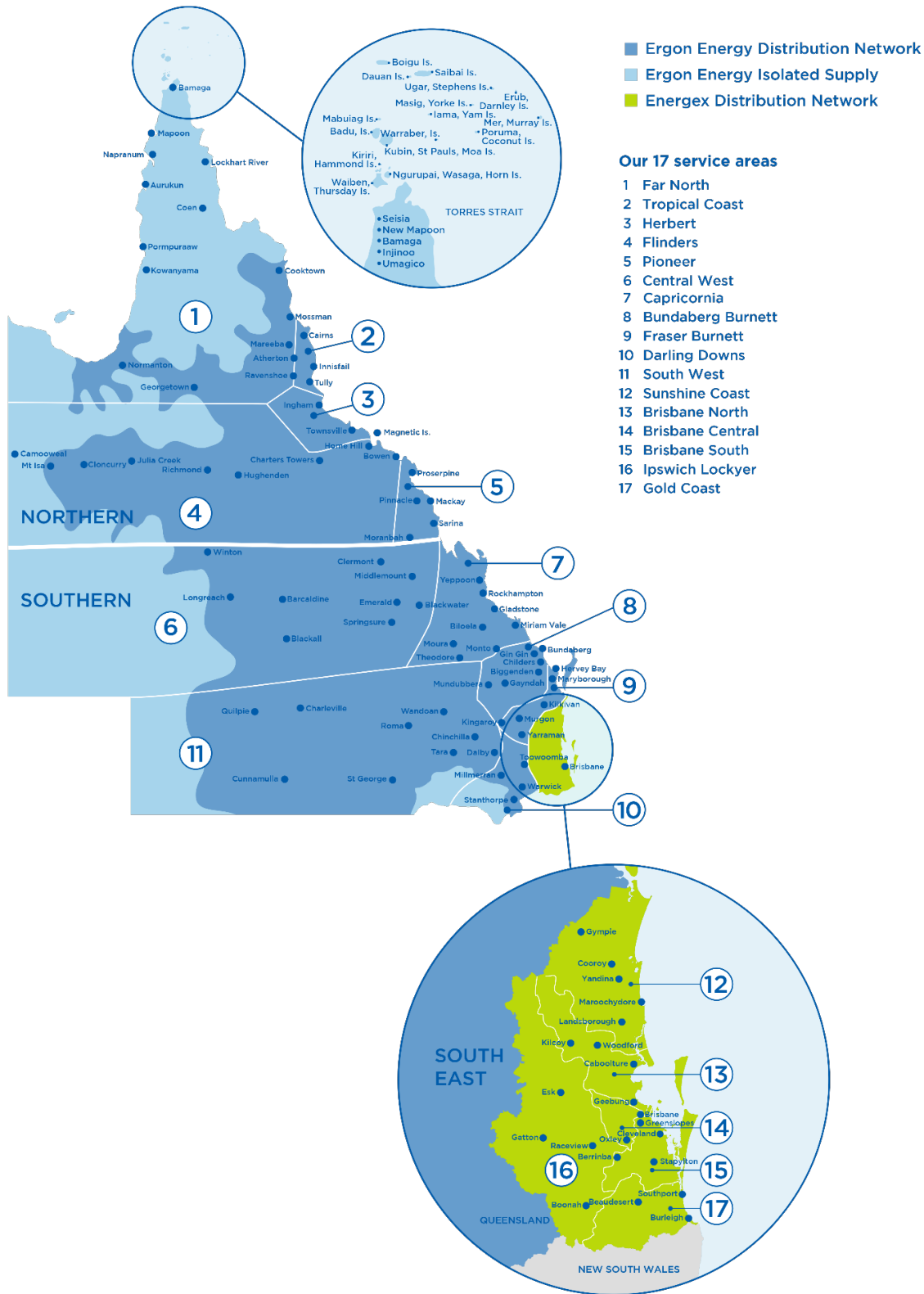

Figure 9: DNSP service area map

## Appendix M: Card Operated Meter Service Areas

**Table 70 Card operated metering areas**

Locality <sup>1</sup>
Arkai, Kubin
Aurukun
Badu, Mulgrave Island
Bamaga
Boigu, Talbot Island
Darnley Island
Dauan Isand
Doomadgee
Gununa, Mornington Island
Hopevale
Injinoo
Jumbun
Kirirri, Hammond Island
Kowanyama
Lockhart River
Mabuiah, Jervis Island
Mapoon
Masig, Yorke Island
Mer, Murray Island
Napranum
New Mapoon
Palm Island
Pormpuraaw
Poruma, Coconut Island
Sabai Island
Seisia
Sue Island, Warraber
Ugar, Stephen Island
Umagico
Wug, St Pauls
Wujal Wujal
Yam Island, lama

## Appendix N: DNSP contact details (informative)

Table 71 DNSP contact details

Contact	Energex	Ergon Energy Network
Website	<a href="http://www.energex.com.au">www.energex.com.au</a>	<a href="http://www.ergon.com.au">www.ergon.com.au</a>
LV CT metering advice	<a href="https://www.energex.com.au/contractors-And-service-providers/document-library/forms">https://www.energex.com.au/contractors-And-service-providers/document-library/forms</a>	<a href="https://www.ergon.com.au/network/contractors-and-industry/electrical-contractors/forms,-manuals-and-standards">https://www.ergon.com.au/network/contractors-and-industry/electrical-contractors/forms,-manuals-and-standards</a>
General Customer service	13 12 53  E-mail requests can be sent to <a href="mailto:custserve@energex.com.au">custserve@energex.com.au</a> or by completing the Contact Form as provided under “Contact Us” on Energex’s website.	13 74 66  E-mail requests can be sent to <a href="mailto:networkenquiries@ergon.com.au">networkenquiries@ergon.com.au</a> or by completing the Contact Form as provided under “Contact Us” on Ergon Energy Network’s website.
Loss of supply	13 62 62	13 22 96
Emergencies	13 19 62	13 16 70
Utility access locks	<a href="https://www.energex.com.au/home/our-services/meters/energex-locks">https://www.energex.com.au/home/our-services/meters/energex-locks</a>	1300 323 301 Purchase utility access locks from API Locksmiths (Queensland Locksmiths) by phone or on-line <a href="http://www.queenslandlocksmiths.com.au">www.queenslandlocksmiths.com.au</a>
Fault level enquiries	<a href="https://www.energex.com.au/about-us/contact-us/forms/general-forms/fault-level-enquiry-form">https://www.energex.com.au/about-us/contact-us/forms/general-forms/fault-level-enquiry-form</a>	<a href="https://www.ergon.com.au/network/network-management/fault-levels/fault-level-enquiry-form">https://www.ergon.com.au/network/network-management/fault-levels/fault-level-enquiry-form</a>
Technical information and QECM advice	1300 762 397 <i>Electrical Contractor Hotline</i> (Licenced Electrical Workers Only) <a href="mailto:qecmmtechadvice@energex.com.au">qecmmtechadvice@energex.com.au</a>	1800 237 466 <i>Electrical Contractor Hotline</i> (Licenced Electrical Workers Only) <a href="mailto:qecmtechadvice@energyq.com.au">qecmtechadvice@energyq.com.au</a>
QECM amendment requests	<a href="mailto:standardsfeedback@energyq.com.au">standardsfeedback@energyq.com.au</a>	



Part of Energy Queensland

[ergon.com.au](http://ergon.com.au)

[energex.com.au](http://energex.com.au)

PO Box 1090, Townsville QLD 4810  
GPO Box 1461, Brisbane QLD 4001

Ergon Energy Network  
ABN 50 087 646 062

Energex is the trading name of  
Energex Limited  
ABN 40 078 849 055